



**CITY OF LAS VEGAS**  
1700 N. GRAND AVE. LAS VEGAS, NEW MEXICO 87701  
505-454-1401 FAX: 505-425-7335

Mayor Tonita Gurule-Giron

**CITY OF LAS VEGAS  
WORK SESSION CITY COUNCIL AGENDA  
January 11, 2017–Wednesday– 5:30 p.m.  
City Council Chambers  
1700 N. Grand Ave**

*(The City Council shall act as the Housing Authority Board of Commissioners on any matters on the Agenda concerning the Housing Department.)*

- I. **CALL TO ORDER**
- II. **ROLL CALL**
- III. **PLEDGE OF ALLEGIANCE**
- IV. **MOMENT OF SILENCE**
- V. **APPROVAL OF AGENDA**
- VI. **PUBLIC INPUT (not to exceed 3 minutes per person and persons must sign up at least fifteen (15) minutes prior to meeting.)**
- VII. **CITY MANAGER'S REPORT**
- VIII. **DISCUSSION ITEMS**

1. Adoption of Graphically updated Official City Seal.

*Annette Velarde, Community Development Director* The official seal of the City of Las Vegas should be updated from time to time to remain visually relevant and appealing. The seal is used as a symbolic means of promoting official City business and should be reflective of iconic features of the City. City staff encouraged public input/feedback for the entire month of December 2016.

2. Contract for Las Vegas/San Miguel Economic Development Corporation.

**Annette Velarde, Community Development Director** The Las Vegas/San Miguel Economic Development Corporation (“EDC”) is a non-profit corporation whose purpose is to promote Las Vegas and San Miguel County as a desirable place to do business, and produce goods and services. The City of Las Vegas seeks to enter into a twelve (12) month contract with the EDC for the purpose of executing the duties and responsibilities of the Local Economic Development Act (“LEDA”) to provide the services and activities as stipulated in the Economic Development plan Ordinance.

3. Contract for Animal Welfare Coalition to service and staff the City of Las Vegas Animal Shelter.

**Annette Velarde, Community Development Director** The Animal Welfare Coalition (“AWC”) is a non-profit corporation whose purpose is to provide humane animal care and animal sheltering services. The City of Las Vegas seeks to enter into a contract with AWC and has negotiated the terms of a contract to render humane animal care and animal sheltering services for the City of Las Vegas.

4. Open Meeting Resolution 17-01.

**Casandra Fresquez, City Clerk** Resolution 17-01 establishes reasonable notice of Council meetings in compliance with Open Meetings Act. Approval of the resolution is required annually.

5. Resolution 16-45 establishing a convenience fee for credit and debit card payment transactions.

**Maria Gilvarry, Utilities Director** The City of Las Vegas does not currently charge a fee for customers to make payments with a credit or debit card which is costing the City approximately \$2,700 per month. Assessing a fee of \$1.25 per transaction will partially offset the expense.

6. Amendment to Bradner Dam Rehabilitation project scope of work.

**Maria Gilvarry, Utilities Director** Upon completion of the Bradner Preliminary Engineering Report, the engineer will obtain permit, design, produce bid documents and supply construction phase engineering services for the Bradner Dam Rehabilitation project. This amendment defines the responsibilities and costs associated with those tasks.

7. Purchase of a 5 yard dump truck.

**Maria Gilvarry, Utilities Director** The Gas Division seeks to purchase a 5 yard dump truck. The current dump truck is over 15 years old and has

lost power which is causing problems when trying to haul trailers loaded with equipment.

8. Award request for bids #2017-12 for natural gas inventory supplies to multiple bidders.

*Maria Gilvarry, Utilities Director* The City of Las Vegas Gas Division must keep their inventory supplies stocked and on hand for gas line repairs as needed. We would like to award to all bidders as prices are lower on different materials for each vendor.

## **IX. EXECUTIVE SESSION**

**THE COUNCIL MAY CONVENE INTO EXECUTIVE SESSION IF SUBJECT MATTER OF ISSUES ARE EXEMPT FROM THE OPEN MEETINGS REQUIREMENT UNDER § (H) OF THE OPEN MEETINGS ACT.**

- A. Personnel matters, as permitted by Section 10-15-1 (H) (2) of the New Mexico Open Meetings Act, NMSA 1978.**
- B. Matters subject to the attorney client privilege pertaining to threatened or pending litigation in which the City of Las Vegas is or may become a participant, as permitted by Section 10-15-1 (H) (7) of the New Mexico Open Meetings Act, NMSA 1978.**
- C. Matters pertaining to the discussion of the sale and acquisition of real property, as permitted by Section 10-15-1 (H) (8) of the Open Meetings Act, NMSA 1978.**

## **X. ADJOURN**

**ATTENTION PERSONS WITH DISABILITES:** The meeting room and facilities are accessible to persons with mobility disabilities. If you plan to attend the meeting and will need an auxiliary aid or service, please contact the City Clerk's Office prior to the meeting so that arrangements may be made.

**ATTENTION PERSONS ATTENDING COUNCIL MEETING:** By entering the City Chambers, you consent to photography, audio recording, video recording and its/their use for inclusion on the City of Las Vegas Web-site, and to be televised on Comcast.

**NOTE:** A final agenda will be posted 72 hours prior to the meeting. Copies of the Agenda may be obtained from City Hall, Office of the City Clerk, 1700 N. Grand Avenue, Las Vegas, N.M 87701

**Work Session**

**CITY COUNCIL MEETING AGENDA REQUEST**

**DATE:** December 28, 2016      **DEPT:** Community Development Dept.

**MEETING DATE:** January 11, 2017

**DISCUSSION ITEM/TOPIC:** Adoption of graphically updated Official City Seal.

**BACKGROUND/RATIONALE:** The official seal of the City of Las Vegas should be updated from time to time to remain visually relevant and appealing. The seal is used as a symbolic means of promoting official City business and should be reflective of iconic features of the City. City staff encouraged public input/feedback for the entire month of December 2016. The proposed seal, background rationale and a phone number and email address to offer opinion or comment was printed and published on the back of all City utility statements throughout the month.

**THIS REQUEST FORM MUST BE SUBMITTED TO THE CITY CLERK'S OFFICE NO LATER THAN 5:00 P.M. ON FRIDAY ONE AND A HALF WEEKS PRIOR TO THE CITY COUNCIL MEETING.**



\_\_\_\_\_  
**SUBMITTER'S SIGNATURE**

**REVIEWED AND APPROVED BY:**



\_\_\_\_\_  
**TONITA GURULÉ-GIRÓN  
MAYOR**



\_\_\_\_\_  
**RICHARD TRUJILLO  
CITY MANAGER**

\_\_\_\_\_  
**ANN MARIE GALLEGOS  
FINANCE DIRECTOR  
(PROCUREMENT)**

\_\_\_\_\_  
**PURCHASING AGENT  
(FOR BID/RFP AWARD)**

\_\_\_\_\_  
**H. CHICO GALLEGOS  
CITY ATTORNEY  
(ALL CONTRACTS MUST BE  
REVIEWED)**

# WE VALUE YOUR OPINION

Dear Neighbor;

Since 1835, the people of Las Vegas have shown great pride and passion in their culture, way of life and heritage. The Gallinas River gave lifeblood to the community and has not quit pumping through our very heart and the veins of the Acequia Madre. Hermits Peak stands as a towering monument, a 360 degree compass leading us to our beloved home.

The ad campaign "So Damn Authentic We Can Prove It" showcases the proof by the hundreds why Las Vegas is so special; from the initial settlement of farmers and ranchers, to those who came to Las Vegas and settled with their families in between Meadows and Mountains, and those who fought for their very way of life. Proof includes the 900+ buildings on the National Historic Register, incredible shopping, food, artesanos, and unbeatable true stories of Outlaws and Rough Riders, entrepreneurs and innovators and those who saw bright potential in the railroad.

A City Seal is a symbol used by the Mayor, Governing Body and Executive Office when preparing official documents and communication. The Seal is *different* from

the City Logo  and strap-line "Old Trails, New Adventures" and the marketing slogan "So Damn Authentic We Can Prove It" which is used in marketing the City of Las Vegas as a tourism destination.

From time to time the Official Seal should be updated to be reflective of the times and culture, and should symbolically reflect our City. Recently the city requested some simple graphic modifications and additions to the seal.



Notable changes:

- ◆ The addition of our founding date.
- ◆ The addition of the Gallinas River.

Please provide your feedback to the City of Las Vegas by January 6, 2017.

You may call and leave your voice opinion 505 426 -3277, or

You may email:

[MyOpinionLasVegasNM@gmail.com](mailto:MyOpinionLasVegasNM@gmail.com); or

You may deliver your handwritten opinion to:

City Seal,  
C/O City of Las Vegas  
1700 North Grand Ave  
Las Vegas, NM 87701

# WE VALUE YOUR OPINION

Dear Neighbor;

Since 1835, the people of Las Vegas have shown great pride and passion in their culture, way of life and heritage. The Gallinas River gave lifeblood to the community and has not quit pumping through our very heart and the veins of the Acequia Madre. Hermits Peak stands as a towering monument, a 360 degree compass leading us to our beloved home.

The ad campaign "So Damn Authentic We Can Prove It" showcases the proof by the hundreds why Las Vegas is so special; from the initial settlement of farmers and ranchers, to those who came to Las Vegas and settled with their families in between Meadows and Mountains, and those who fought for their very way of life. Proof includes the 900+ buildings on the National Historic Register, incredible shopping, food, artesanos, and unbeatable true stories of Outlaws and Rough Riders, entrepreneurs and innovators and those who saw bright potential in the railroad.

A City Seal is a symbol used by the Mayor, Governing Body and Executive Office when preparing official documents and communication. The Seal is *different* from

the City Logo  and strap-line "Old Trails, New Adventures" and the marketing slogan "So Damn Authentic We Can Prove It" which is used in marketing the City of Las Vegas as a tourism destination.

From time to time the Official Seal should be updated to be reflective of the times and culture, and should symbolically reflect our City. Recently the city requested some simple graphic modifications and additions to the seal.



Notable changes:

- ◆ The addition of our founding date.
- ◆ The addition of the Gallinas River.

Please provide your feedback to the City of Las Vegas by January 6, 2017.

You may call and leave your voice opinion 505 426 -3277, or

You may email:

[MyOpinionLasVegasNM@gmail.com](mailto:MyOpinionLasVegasNM@gmail.com); or

You may deliver your handwritten opinion to:

City Seal,  
C/O City of Las Vegas  
1700 North Grand Ave  
Las Vegas, NM 87701

# WE VALUE YOUR OPINION

Dear Neighbor,

Since 1835, the people of Las Vegas have shown great pride and passion in their culture, way of life and heritage. The Gallinas River gave lifeblood to the community and has not quit pumping through our very heart and the veins of the Acequia Madre. Hermits Peak stands as a towering monument, a 360 degree compass leading us to our beloved home.

The ad campaign "So Damn Authentic We Can Prove It" showcases the proof by the hundreds why Las Vegas is so special; from the initial settlement of farmers and ranchers, to those who came to Las Vegas and settled with their families in between Meadows and Mountains, and those who fought for their very way of life. Proof includes the 900+ buildings on the National Historic Register, incredible shopping, food, artesanos, and unbeatable true stories of Outlaws and Rough Riders, entrepreneurs and innovators and those who saw bright potential in the railroad.

A City Seal is a symbol used by the Mayor, Governing Body and Executive Office when preparing official documents and communication. The Seal is **different** from

the City Logo  and strap-line "Old Trails, New Adventures" and the marketing slogan "So Damn Authentic We Can Prove It" which is used in marketing the City of Las Vegas as a tourism destination.

From time to time the Official Seal should be updated to be reflective of the times and culture, and should symbolically reflect our City. Recently the city requested some simple graphic modifications and additions to the seal.



Notable changes:

- ◆ The addition of our founding date.
- ◆ The addition of the Gallinas River.

Please provide your feedback to the City of Las Vegas by January 6, 2017.

You may call and leave your voice opinion 505 426 -3277, or

You may email:

[MyOpinionLasVegasNM@gmail.com](mailto:MyOpinionLasVegasNM@gmail.com); or

You may deliver your handwritten opinion to:

City Seal,  
C/O City of Las Vegas  
1700 North Grand Ave  
Las Vegas, NM 87701

# WE VALUE YOUR OPINION

Dear Neighbor;

Since 1835, the people of Las Vegas have shown great pride and passion in their culture, way of life and heritage. The Gallinas River gave lifeblood to the community and has not quit pumping through our very heart and the veins of the Acequia Madre. Hermits Peak stands as a towering monument, a 360 degree compass leading us to our beloved home.

The ad campaign "So Damn Authentic We Can Prove It" showcases the proof by the hundreds why Las Vegas is so special; from the initial settlement of farmers and ranchers, to those who came to Las Vegas and settled with their families in between Meadows and Mountains, and those who fought for their very way of life. Proof includes the 900+ buildings on the National Historic Register, incredible shopping, food, artesanos, and unbeatable true stories of Outlaws and Rough Riders, entrepreneurs and innovators and those who saw bright potential in the railroad.

A City Seal is a symbol used by the Mayor, Governing Body and Executive Office when preparing official documents and communication. The Seal is **different** from

the City Logo  and strap-line "Old Trails, New Adventures" and the marketing slogan "So Damn Authentic We Can Prove It" which is used in marketing the City of Las Vegas as a tourism destination.

From time to time the Official Seal should be updated to be reflective of the times and culture, and should symbolically reflect our City. Recently the city requested some simple graphic modifications and additions to the seal.



Notable changes:

- ◆ The addition of our founding date.
- ◆ The addition of the Gallinas River.

Please provide your feedback to the City of Las Vegas by January 6, 2017.

You may call and leave your voice opinion 505 426 -3277, or

You may email:

[MyOpinionLasVegasNM@gmail.com](mailto:MyOpinionLasVegasNM@gmail.com); or

You may deliver your handwritten opinion to:

City Seal,  
C/O City of Las Vegas  
1700 North Grand Ave  
Las Vegas, NM 87701



# WE VALUE YOUR OPINION

Dear Neighbor,

Since 1835, the people of Las Vegas have shown great pride and passion in their culture, way of life and heritage. The Gallinas River gave lifeblood to the community and has not quit pumping through our very heart and the veins of the Acequia Madre. Hermits Peak stands as a towering monument, a 360 degree compass leading us to our beloved home.

The ad campaign "So Damn Authentic We Can Prove It" showcases the proof by the hundreds why Las Vegas is so special; from the initial settlement of farmers and ranchers, to those who came to Las Vegas and settled with their families in between Meadows and Mountains, and those who fought for their very way of life. Proof includes the 900+ buildings on the National Historic Register, incredible shopping, food, artesanos, and unbeatable true stories of Outlaws and Rough Riders, entrepreneurs and innovators and those who saw bright potential in the railroad.

A City Seal is a symbol used by the Mayor, Governing Body and Executive Office when preparing official documents and communication. The Seal is *different* from

the City Logo  and strap-line "Old Trails, New Adventures" and the marketing slogan "So Damn Authentic We Can Prove It" which is used in marketing the City of Las Vegas as a tourism destination.

From time to time the Official Seal should be updated to be reflective of the times and culture, and should symbolically reflect our City. Recently the city requested some simple graphic modifications and additions to the seal.



Notable changes:

- ◆ The addition of our founding date.
- ◆ The addition of the Gallinas River.

Please provide your feedback to the City of Las Vegas by January 6, 2017.

You may call and leave your voice opinion 505 426 -3277, or

You may email:

[MyOpinionLasVegasNM@gmail.com](mailto:MyOpinionLasVegasNM@gmail.com); or

You may deliver your handwritten opinion to:

City Seal,  
C/O City of Las Vegas  
1700 North Grand Ave  
Las Vegas, NM 87701

# WE VALUE YOUR OPINION

Dear Neighbor,

Since 1835, the people of Las Vegas have shown great pride and passion in their culture, way of life and heritage. The Gallinas River gave lifeblood to the community and has not quit pumping through our very heart and the veins of the Acequia Madre. Hermits Peak stands as a towering monument, a 360 degree compass leading us to our beloved home.

The ad campaign "So Damn Authentic We Can Prove It" showcases the proof by the hundreds why Las Vegas is so special; from the initial settlement of farmers and ranchers, to those who came to Las Vegas and settled with their families in between Meadows and Mountains, and those who fought for their very way of life. Proof includes the 900+ buildings on the National Historic Register, incredible shopping, food, artesanos, and unbeatable true stories of Outlaws and Rough Riders, entrepreneurs and innovators and those who saw bright potential in the railroad.

A City Seal is a symbol used by the Mayor, Governing Body and Executive Office when preparing official documents and communication. The Seal is *different* from

the City Logo  and strap-line "Old Trails, New Adventures" and the marketing slogan "So Damn Authentic We Can Prove It" which is used in marketing the City of Las Vegas as a tourism destination.

From time to time the Official Seal should be updated to be reflective of the times and culture, and should symbolically reflect our City. Recently the city requested some simple graphic modifications and additions to the seal.



Notable changes:

- ◆ The addition of our founding date.
- ◆ The addition of the Gallinas River.

Please provide your feedback to the City of Las Vegas by January 6, 2017.

You may call and leave your voice opinion 505 426 -3277, or

You may email:

[MyOpinionLasVegasNM@gmail.com](mailto:MyOpinionLasVegasNM@gmail.com); or

You may deliver your handwritten opinion to:

City Seal,  
C/O City of Las Vegas  
1700 North Grand Ave  
Las Vegas, NM 87701

# WE VALUE YOUR OPINION

Dear Neighbor,

Since 1835, the people of Las Vegas have shown great pride and passion in their culture, way of life and heritage. The Gallinas River gave lifeblood to the community and has not quit pumping through our very heart and the veins of the Acequia Madre. Hermits Peak stands as a towering monument, a 360 degree compass leading us to our beloved home.

The ad campaign "So Damn Authentic We Can Prove It" showcases the proof by the hundreds why Las Vegas is so special; from the initial settlement of farmers and ranchers, to those who came to Las Vegas and settled with their families in between Meadows and Mountains, and those who fought for their very way of life. Proof includes the 900+ buildings on the National Historic Register, incredible shopping, food, artesanos, and unbeatable true stories of Outlaws and Rough Riders, entrepreneurs and innovators and those who saw bright potential in the railroad.

A City Seal is a symbol used by the Mayor, Governing Body and Executive Office when preparing official documents and communication. The Seal is *different* from

the City Logo  and strap-line "Old Trails, New Adventures" and the marketing slogan "So Damn Authentic We Can Prove It" which is used in marketing the City of Las Vegas as a tourism destination.

From time to time the Official Seal should be updated to be reflective of the times and culture, and should symbolically reflect our City. Recently the city requested some simple graphic modifications and additions to the seal.



Notable changes:

- ◆ The addition of our founding date.
- ◆ The addition of the Gallinas River.

Please provide your feedback to the City of Las Vegas by January 6, 2017.

You may call and leave your voice opinion 505 426 -3277, or

You may email:

[MyOpinionLasVegasNM@gmail.com](mailto:MyOpinionLasVegasNM@gmail.com); or

You may deliver your handwritten opinion to:

City Seal,  
C/O City of Las Vegas  
1700 North Grand Ave  
Las Vegas, NM 87701

## Work Session

### CITY COUNCIL MEETING AGENDA REQUEST

**DATE:** December 28, 2016      **DEPT:** Community Development Dept.

**MEETING DATE:** January 11, 2017

**DISCUSSION ITEM/TOPIC:** Contract for Las Vegas/San Miguel Economic Development Corporation.

**BACKGROUND/RATIONALE:** The Las Vegas/San Miguel Economic Development Corporation ("EDC") is a non-profit corporation whose purpose is to promote Las Vegas and San Miguel County as a desirable place to do business, and produce goods and services. The City of Las Vegas seeks to enter into a twelve (12) month contract with the EDC for the purpose of executing the duties and responsibilities of the Local Economic Development Act ("LEDA") and to provide the services and activities as stipulated in the Economic Development Plan Ordinance. The EDC will also respond to applicable Potential Recruitment Opportunities ("PRO's") initiated by the State of New Mexico Economic Development Department. The EDC will also conduct its regular responsibilities of attracting new business start-ups, assisting existing small businesses to expand, and attracting new business to Las Vegas and San Miguel County.

**THIS REQUEST FORM MUST BE SUBMITTED TO THE CITY CLERK'S OFFICE NO LATER THAN 5:00 P.M. ON FRIDAY ONE AND A HALF WEEKS PRIOR TO THE CITY COUNCIL MEETING.**



**SUBMITTER'S SIGNATURE**

**REVIEWED AND APPROVED BY:**



**TONITA GURULÉ-GIRÓN  
MAYOR**

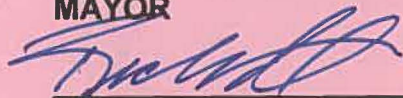

**RICHARD TRUJILLO  
CITY MANAGER**

**ANN MARIE GALLEGOS  
FINANCE DIRECTOR  
(PROCUREMENT)**

**PURCHASING AGENT  
(FOR BID/RFP AWARD)**

**H. CHICO GALLEGOS  
CITY ATTORNEY  
(ALL CONTRACTS MUST BE  
REVIEWED)**

**CONTRACT BETWEEN THE CITY OF LAS VEGAS, NEW MEXICO  
AND  
LAS VEGAS/SAN MIGUEL ECONOMIC DEVELOPMENT CORPORATION**

This contract entered into this \_\_\_\_ day of \_\_\_\_\_, and effective January 1, 2017 thru December 31, 2017, between the City of Las Vegas, New Mexico, a municipal corporation, hereinafter called the "City" and Las Vegas/San Miguel Economic Development Corporation, a non-profit corporation, hereinafter called the "Contractor."

**WHEREAS**, the Contractor is a non-profit corporation, whose purpose is to promote Las Vegas and San Miguel County as a desirable place to do business, produce goods and services, and educate.

**WHEREAS**, the City commits financial support through December 31, 2017, prorated on a quarterly basis in an amount during contract period not to exceed Fifteen Thousand and 00/100 Dollars (\$15,000.00) to be paid to the Contractor under the terms and conditions of this Contract.

**NOW THEREFORE, THE PARTIES AGREE AS FOLLOWS:**

The City will pay on invoices presented under this Contract where work (described under Addendum A, Scope of Work attached hereto and in accordance with Economic Development Plan and City Ordinance 01-19, Chapter 33, Addendum B) have been completed and services have been provided to the City in said Addendum(s). To be paid for any invoice, the Contractor must be current in reporting requirements. The requirements are as follows:

**A. SCOPE OF WORK**

See Addendum A and B Scope of Work attached hereto.

**B. EXECUTION OF SCOPE OF WORK**

Contractor shall implement the Scope of Work as detailed in Addendum A and B.

**C. DELIVERABLES**

Contractor shall submit a deliverable implementation report and financial report on a quarterly basis for review and approval by the Community Development Director with a copy to the City Manager's office prior to the City making payment to the Contractor. The report must include, but is not limited to, all activities conducted by the Contractor as outlined in the Scope of Work, and all revenues and expenditures, to include any revenues from sources other than the City.

**D. FINANCIAL REVIEW**

Contractor shall have a detailed financial review of all expenditures related to this contract during the contract. This review must be provided by an independent third party. Any costs for this review must be paid by Contractor.

## **E. PAYMENT**

Payment to the Contractor shall be prorated from the date of contract through the end of the contract and may be made on a quarterly basis, submittal of invoices and support documentation, and the receipt of a deliverable implementation report and financial report.

Invoices shall include (i) Contractor name and address, (ii) description of the work performed or services acquired, (iii) the amount of payment requested, and (iv) a certification by an authorized officer of the Contractor as to the statements set forth in the invoice, (v) any other detailed reporting as indicated in Addendum A attached and made part of this document. The Contractor shall submit reports and original invoices to the Community Development Department with a copy to the City Manager's office.

## **F. INSURANCE**

Contractor will furnish the City's Finance Director with a Certificate of Insurance prior to disbursement of any funds. The insurance shall cover any and all activities engaged in and sponsored by Contractor and shall name the City as an additional insured.

## **G. HOLD HARMLESS**

Contractor shall hold harmless, indemnify and defend the City and its "public employees" as defined in the New Mexico Tort Claims Act, Sections 41-4-1 to 41-4-29, NMSA 1978, as amended, against and from any and all claims losses, demands, judgments, damages, liabilities, lawsuits, expenses, attorney fees, and/or actions of any kind and nature, whether from death, bodily injury or damage to property resulting from, or related to, the Contractor's negligence or intentional acts, errors or omissions in the Contractor's performance under this Contract. The Contractor's agreement to hold harmless, indemnify and defend shall not be affected nor terminated by the cancellation or expiration of the term or any renewal or any other modification of this Contract for any reason, and shall survive the cancellation or expiration of the term or any renewal or any other modification of the Contract for negligence acts, errors or omissions to act occurring during the term of this Contract.

## **H. DISCLOSURE TO THE CITY**

Any additional means of funding to include contracts and/or sub-contracts held by the Contractor with other funding entities shall be disclosed to the City prior to the execution of this contract. In addition, at such times and in such form as the City Council may require, Contractor shall furnish to the City, such statements, records, reports, data and information as the City may request pertaining to matters covered by this Agreement, and the Provider will permit the City to audit, examine and make excerpts of transcripts from such records, and make audit of all data relating to all matters covered by this agreement subject to the limitations set out above.

## **I. NO FINANCIAL INTEREST**

No officer or employee of the City or of the Contractor who exercises any function of responsibility in connection with the planning and implementation of any of the provisions of this Contract shall have

any direct personal financial interest in this Contract, and the Contractor shall take appropriate steps to assure compliance.

The City and Contractor acknowledge that Bill Hendrickson is the Executive Director and Denice Spicer is the Administrative Aid for the Las Vegas/San Miguel Economic Development Corporation and are paid employees of the Contractor.

**J. PREJUDICE**

No person, on account of race, color, religion, national origin or because of non-membership in the Contractor's organization shall be excluded from participating in, or denied benefits of any activity made possible through and resulting from this Contract.

**K. POLITICAL ACTIVITY**

None of the funds, materials, property or services rendered directly or indirectly under this Contract shall be used for any political activity, or to further the election or defeat of any candidate for state, federal or local office.

**L. ASSIGNMENT**

Contractor shall not assign any interest in this Contract, excluding payments for services by the Contractor, as provided for above and shall not transfer any interest in the same (whether by assignment or novation), without the prior written consent of the City thereto. Provided, however, that claims for money due, or to become due, to the Contractor from the City under this Contract may be assigned to a bank, trust company or other financial institution without such approval.

**M. SUBJECT TO LAWS**

Contractor shall comply at its own cost with all applicable laws, ordinances and codes of the federal, state and local governments.

**N. NO FURTHER LIABILITY**

The City shall not be obligated or liable under this Contract to any party other than the Contractor for payment of any monies, to include payroll taxes or for provision of any goods or services unless such liabilities are specifically agreed to in this Contract.

**O. JURISDICTION**

It is mutually agreed by and between the parties hereto that this Contract shall be performed in Las Vegas, San Miguel County, New Mexico, and further that any legal action or causes of action in connection, herewith, will be within the jurisdiction of the appropriate court in San Miguel County, New Mexico, for all purposes.

## **P. TERMINATION**

The City may, with or without cause, terminate this Contract at any time upon thirty (30) days written notice of termination given to the Contractor. In such event, all finished or unfinished documents, data studies, photographs, reports and the rights to any property prepared or procured by the Contractor under this Contract shall, at the option of the City, become equitable compensation for any work satisfactorily completed through the termination date. Similarly, the Contractor may, with or without causes, terminate this Contract upon a thirty (30) day written notice, and the City shall reimburse the Contractor for any and all expenses incurred that have not been reimbursed prior to the time of notification provided those expenses otherwise proper hereunder.

## **Q. ENTIRE AGREEMENT**

This Contract constitutes the entire Contract between the parties hereto; any prior Contract, whether written or oral, or assertion or statement, or understanding or other commitment antecedent to the Contract shall not have any force or effect whatsoever, unless the same is mutually agreed to by the parties hereto and reduced to writing. No changes or amendments to this Contract shall be effective except those on written approval by both parties.

## **R. AMENDMENT**

This Contract will not be altered, changed or amended except by a written document signed by the parties to this Contract.

## **S. AUTHORITY TO BIND THE CITY**

Contractor shall not have the authority to enter into any Contract/Agreement binding upon the City or to create any obligation on the part of the City, except such as shall be specifically authorized by the City's governing body or by the City Manager acting upon authority granted by the City's governing body.

## **T. NOTICES**

Any notices required to be given under this Contract shall be deemed sufficient, if given in writing, by mail, to the principal office of the City or to the principal office of the Contractor.

## **U. BRIBERY AND KICKBACKS**

As required by Section 13-1-191, NMSA 1978, as amended, it should be noted that it is a third degree felony under New Mexico Law to commit the offense of bribery of a public officer or public employee Section 30-24-1, NMSA 1978, as amended; it is a third degree felony to commit the offense of demanding or receiving a bribe by a public officer or public employee, Section 30-24-2, NMSA 1978, as amended; it is a fourth degree felony to commit the offense of soliciting or receiving illegal kickbacks, Section 30-41-1, NMSA 1978, as amended; it is a fourth degree felony to commit the offense of offering or paying illegal kickbacks, Section 30-41-2, NMSA 1978, as amended.



**V. NEW MEXICO TORT CLAIMS ACT**

Any liability incurred by the City of Las Vegas in connection with this Agreement is subject to the immunities and limitations of the New Mexico Tort Claims Act, Section 41-4-1, et. seq. NMSA 1978, as amended. The City and its "public employees" as defined in the New Mexico Tort Claims Act, do not waive sovereign immunity, do not waive any defense and do not waive any limitation of liability pursuant to law. No provision in this Agreement modifies or waives any provision of the New Mexico Tort Claims Act.

**W. THIRD PARTY BENEFICIARIES**

By entering into this Agreement, the parties do not intend to create any right, title or interest in or for the benefit of any person other than the City and the Contractor. No person shall claim any right, title or interest under this Agreement or seek to enforce this Agreement as a third party beneficiary under this Agreement.

**X. TERM**

The term of this Contract will be **January 1, 2017 thru December 31, 2017**. Should the Contractor wish to renew this Contract, the Contractor must provide written notice to the City at least ninety (90) days prior to the anniversary date.

**Y. APPEAL**

The City Manager shall have the final say as to the meaning of this contract, including, but not limited to, whether the deliverables were met or the duties were fulfilled. Contractor and its members or agents understand that they may appeal the decision of the City Manager to the Governing Body.

**SIGNED:**

\_\_\_\_\_  
Richard Trujillo, City Manager

\_\_\_\_\_  
Las Vegas/San Miguel Economic  
Development Corporation

**REVIEWED AND APPROVED AS TO LEGAL SUFFICIENCY:**

  
\_\_\_\_\_  
H. Chico Gallegos, City Attorney

**ATTEST:**

\_\_\_\_\_  
Casandra Fresquez, City Clerk

## Addendum A Scope of Work

Contractor, the Las Vegas/San Miguel Economic Development Corporation (“EDC”) shall:

Execute the duties and responsibilities of the Local Economic Development Act (“LEDA”) and provide the services and activities as stipulated in Addendum B, Economic Development Plan Ordinance. The EDC will respond to applicable Potential Recruitment Opportunities “(PRO’s) initiated by the State of New Mexico Economic Development Department and immediately notify City of Las Vegas of such Potential Recruitment Opportunities.

Additionally, the EDC will conduct its regular responsibilities to

- Attract new business start-ups.
- Assist existing small businesses to expand.
- Attract new business to Las Vegas and San Miguel County.

**Addendum B**  
**Economic Development Plan Ordinance**

## Chapter 33. Economic Development Plan

[HISTORY: Adopted by the City Council of the City of Las Vegas 1-9-2002 by Ord. No. 01-19; amended in its entirety 7-1-2009 by Ord. No. 09-13. Subsequent amendments noted where applicable.]

### **GENERAL REFERENCES**

Infrastructure gross receipts tax — See Ch. 389, Art. II.

### § 33-1. Short title.

This chapter may be cited as the "Economic Development Plan Ordinance."

### § 33-2. Authority.

The Economic Development Plan Ordinance is enacted pursuant to the statutory authority conferred upon municipalities to allow public support of economic development (NMSA 1978, §§ 5-10-1 through 5-10-13). This chapter is adopted as part of the City's economic development plan.

### § 33-3. Purpose.

- A. The purpose of the Economic Development Plan/Ordinance is to allow public support of economic projects to foster, promote and enhance local economic development efforts while continuing to protect against the unauthorized use of public money and other public resources. Further, the purpose of this chapter is to allow the City to enter into one or more joint powers agreements with other local governments to plan and support regional economic development projects.
- B. Local Economic Development Act. Local governments are allowed to provide direct or indirect assistance to qualifying businesses for furthering or implementing economic development plans and projects; furthermore local and regional governments have the authority to contribute assets to development projects; however, the imposition of a tax must be approved by the voters in referendum.
- C. Eligible uses. Municipalities may impose municipal infrastructure gross receipts tax and dedicate the revenue for economic development projects. A total of 0.25% tax (in four increment of 0.0625%) may be imposed.

### § 33-4. Definitions.

As used in this chapter, the following terms shall have the meanings indicated:

#### **ARTS AND CULTURAL DISTRICT**

A facility that is owned by the state, a county, a municipality or a qualifying entity that serves the public through preserving, educating and promoting the arts and culture of a particular locale, including theaters, museums, libraries, galleries, cultural compounds, educational organizations,

performing arts venues and organizations, fine arts organizations, studios and media laboratories and live-work housing facilities.

### **ECONOMIC DEVELOPMENT PROJECT or PROJECT**

The provision of direct or indirect assistance to a qualifying entity by a local or regional government and includes the purchase, lease, grant, construction, reconstruction, improvement or other acquisition or conveyance of land, buildings or other infrastructure; public works improvements essential to the location or expansion of a qualifying entity; payments for professional services contracts necessary for local or regional governments to implement a plan or project; the provision of direct loans or grants for land, buildings or infrastructure; technical assistance to cultural facilities; loan guarantees securing the cost of land, buildings or infrastructure in an amount not to exceed the revenue that may be derived from the municipal infrastructure gross receipts tax or the county infrastructure gross receipts tax; grants for public works infrastructure improvements essential to the location or expansion of a qualifying entity; grants or subsidies to cultural facilities; purchase of land for a publicly held industrial park or a publicly owned cultural facility; and the construction of a building for use by a qualifying entity.

### **GOVERNING BODY**

The City Council of Las Vegas.

### **PROJECT PARTICIPATION AGREEMENT**

An agreement between a qualifying entity and the City whereby the City provides assistance to an economic development project in exchange for the benefits received as set forth in this section.

### **QUALIFYING ENTITY**

An existing or proposed corporation, limited liability company, partnership, joint venture, syndicate, association or other person that is one or combination of two or more of the following:

- A. An industry for manufacturing, processing, or assembling of any agricultural or manufactured products;
- B. A commercial enterprise for storing, warehousing, distributing, or selling products of agriculture, mining or industry, but other than provided in Subsection **D** of this definition, not including any enterprise for sale of goods or commodities at retail or for the distribution to the public of electricity, gas, water, or telephone or other services commonly classified as public utilities;
- C. A business in which all or part of the activities of the business involves the supplying of services to the general public or to government agencies or to a specific industry or customer, but, other than provided in Subsection **D** of this definition, not including business primarily engaged in the sale of goods or commodities at retail;
- D. A telecommunications sales enterprise that makes the majority of its sales to persons outside of New Mexico.

## **§ 33-5. City assistance with economic development projects.**

- A. The City Manager after approval of the governing body may assist economic development projects in any legally permissible manner, including but not limited to provisions of land, buildings and infrastructure, provided that all the requirements of this chapter are met. The City may provide land, buildings or infrastructure it already owns, or it may build, purchase or lease the facilities needed for an economic development project. The City at its discretion may bear the full cost or contribute a portion of the costs, including the waiver of applicable fees. The City, at its discretion, may also contribute to the payment of costs for professional service contracts such as industry feasibility studies and planning and design services needed to implement a project.
- B. The governing body may consider offering all forms of assistance allowed under this chapter and any other legally permissible forms of assistance; however, this does not establish any obligation on

the City's part to offer any specific type or level of assistance.

## **§ 33-6. Las Vegas San Miguel Economic Development Corporation.**

- A. The governing body assigns the Las Vegas San Miguel Economic Development Corporation (LVSMEDC) Board of Directors the following responsibilities with regard to the economic development plan for the City of Las Vegas:
  - (1) Reviewing and making recommendations to the governing body on applications for assistance for economic development projects; and
  - (2) Reviewing and making recommendations to the governing body on applications for industrial revenue bonds (IRBS).
- B. The LVSMEDC shall at all times provide for a Board of Directors position for the City of Las Vegas, the Mayor shall appoint a member of the Board of Directors with the advice and consent of the City Council.

## **§ 33-7. Application requirements.**

- A. Any qualifying entity meeting the definition set forth in the definition of "qualifying entity" in § 33-4 may propose an economic development project to the City. Meeting the definition of a "qualifying entity" does not create any obligation on the part of the City of Las Vegas.
- B. Applications from qualifying entities shall be submitted to the City of Las Vegas on forms approved by the City.
- C. Applications shall contain the following information for business applicants:
  - (1) Identification information:
    - (a) Complete name and address of entity;
    - (b) Incorporation papers with bylaws;
    - (c) List of board of directors and executive director, with addresses; and
    - (d) Resumes of all directors and officers.
  - (2) Evidence of financial solvency (personal statement of principals):
    - (a) Financial statement (income statement and balance sheets) for the past three years;
    - (b) Federal tax number, New Mexico State taxation and revenue number and county business license;
    - (c) Projected income statement for at least three years.
  - (3) Evidence of organizational capacity:
    - (a) Brief history of the entity;
    - (b) Organizational chart of the entity;
    - (c) Business plans for the entity and proposed project (shall include three-year pro-forma cash flow analysis);
    - (d) Evidence of ability to manage the project, such as, but not limited to:

- [1] List and description of previously completed projects;
  - [2] Resumes of key staff involved with project.
- (e) Entity shall disclose the following information (if the answers is yes the entity shall attach a written explanation):
- [1] Has the business or any of its officers ever been involved in a bankruptcy?
  - [2] Has the business or any of its officers ever defaulted obligations on which payments are not current?
  - [3] Does the entity have any loans or other financial obligations on which payments are not current?
- (4) The project participation agreement and any other pertinent information will be forwarded to the governing body for final consideration at a public meeting.
- (5) Funding source for project:
- (a) Equity investment of qualifying entity;
  - (b) Assistance being request of the City (e.g., specific parcel of land, applicable fees, etc.), with estimate of value; and
  - (c) Funding sources other than the City with letters of commitment of intend to fund.
- (6) Identification of the terms, conditions, location, scope and requirements to the economic development project.
- (7) Information sufficient for the LVSMEDC to make its determination whether the applicant is a qualifying entity.
- (8) Any other information required of the applicant by the LVSMEDC or governing body.

## § 33-8. Applicable review process.

- A. The LVSMEDC Board of Directors shall determine whether the entity and the proposed project qualify under this chapter.
- B. The LVSMEDC Board of Directors shall then coordinate with the qualifying entity to develop a project participation agreement as set forth in § 33-11.
- C. The LVSMEDC Board of Directors shall consider the economic development project participation agreement in accordance with the criteria set forth in § 33-9. The LVSMEDC Board of Directors shall recommend to the governing body that the proposal be adopted, conditionally adopted or not adopted.
- D. The recommendation will be forwarded with the project participation agreement, minutes of the LVSMEDC meeting and any other pertinent information to the governing body for final consideration at a public meeting.

## § 33-9. Applicable review criteria.

- A. Applications for economic development projects requesting economic assistance from the City, which meet the policies and objectives of the City's economic development plan, shall receive priority. Examples include, but are not limited to:
  - (1) Manufacturing firms (including intellectual property such as computer software);

- (2) Projects, which enhance the exporting capacity of companies and/or provide goods and services, which currently have to be imported into Las Vegas;
  - (3) Private companies seeking to build, expand or relocate facilities;
  - (4) Private companies which provide facilities or services which enhance the ability of Las Vegas businesses to operate;
  - (5) Organizations, which assist business start-ups or bring small companies together to increase their competitive abilities. This must involve a tangible project, which will create jobs and promote an industry. Examples include, but are not limited to:
    - (a) Business incubators;
    - (b) Art incubators or coalition (e.g., a performing arts coalition seeking construction rehearsal or performance facilities);
    - (c) Public markets for farmers, gardeners, crafts, etc.; and
    - (d) Organizations which foster economic development by promoting work force development efforts such as apprenticeships or other job training programs;
  - (6) Projects in industry clusters listed above are particularly encouraged, but others are eligible to apply as well. The intention is to retain flexibility in the use of incentives; and
  - (7) Qualifying entities with existing contract or projects with the City when this plan is adopted may propose a restructuring of their projects as an economic development project.
- B. All applications for economic development projects requesting economic assistance from the City shall submit a cost benefit analysis. Preparing a cost benefit analysis shall be the responsibility of the applicant. The City retains the right to specify a format and methodology for the cost-benefit analysis. The LVSMEDEC shall review and approve the methodology used. The source and rationale for any multiplier effects shall be identified. The cost-benefit analysis shall show that the City will recoup the value of its donation within a period of 10 years. The analysis shall address the following:
- (1) The number and type of jobs to be created, retained, both temporary construction jobs and permanent jobs (by New Mexico Department of Labor job category);
  - (2) Pay scale of jobs;
  - (3) Determination of which jobs are expected to be filled locally and which will be filled by transfers from other facilities or recruited from outside the Las Vegas area;
  - (4) Total payroll expected at start-up and after one year;
  - (5) Anticipated impact on local tax base; and
  - (6) Anticipated impact on local school systems.
- C. All applicants for economic development projects requesting economic assistance from the City shall require the same review required of industrial revenue bond applications. This review shall focus on environmental and community impacts of proposed projects. Special attention shall be given to job training and career advancement programs and policies. Projects shall demonstrate a strong commitment to providing career opportunities for Las Vegas area residents. Cultural impacts of projects shall also be considered.
- D. Any qualifying entity seeking assistance shall prepare and make available a job training and career development plan for their employees.
- E. All applicants for economic development projects requesting economic assistance from the City shall clearly demonstrate the benefits, which will accrue to the community as a result of the donation of public resources. The City has considerable flexibility in determining what is considered as adequate benefits. Benefits such as providing components or production capabilities, which



enhance a targeted industry cluster, or addressing critical deficiencies in regional economy, may be recognized. The benefits claimed of any proposal will receive careful scrutiny. However, it is the intent of this chapter to be flexible in the evaluation of these benefits, and to recognize the qualitative as well as quantitative impact of a proposal.

- F. All applicants for economic development projects requesting assistance from the City shall clearly demonstrate how the qualifying entity is making a substantive contribution. The contribution shall be of value and may be paid in money, in-kind services, jobs, expanded tax base, property or other thing or service of value for the expansion or improvement of the economy. The City retains flexibility in defining the "substantive contributions." The benefits identified in the previous paragraphs may be accepted as adequate contributions on their own, or as cash donations may be required. Assistance in providing affordable housing to its employees or the community at large may also qualify. Determination of what constitutes an acceptable contribution for a given project shall be at the discretion of the governing body.

## § 33-10. Public safeguards.

- A. All economic development projects receiving assistance from the City shall be subject to an annual performance review conducted by the LVSMEDC. This review shall evaluate whether the project is attaining the goals and objectives set forth in the project participation agreement. This review shall be presented to the governing body for its consideration. The governing body at a public hearing may terminate assistance to the economic development project by provisions set forth in the agreement, which terminates the agreement and specifies the disposition of all assets and obligations of the project.
- B. The City shall retain a security interest, which shall be specific in the project participation agreement. The type of security given shall depend upon the nature of economic development project and assistance provided by the City. Types of security may include, but are not limited to:
  - (1) Letter of credit in the City's name;
  - (2) Performance bond equal to the City's contribution;
  - (3) A mortgage or lien on the property or equipment;
  - (4) Prorated reimbursement of donation if company reduces work force or leaves the community before the term agreed to; and
  - (5) Other security agreeable to both parties.
- C. Should a qualifying entity move, sell, lease or transfer a majority interest in the economic development project before the expiration of the project participation agreement, the City retains the right to deny any and all assignments, sales, leases or transfers of any interests in the economic development project until adequate assurances are made that the transferee, assignee or lessee is a qualifying entity and that the terms of the agreement will be satisfied by the transferee, assignee or lessee. At its discretion, the City may choose to deny said assignment, lease or transfer or may negotiate a new agreement with the new operator, or the City may reclaim the facility and enter into an agreement with the new qualifying entity.
- D. Any qualifying entity seeking assistance from public resources shall commit to operate in accordance with its project participation agreement for a minimum of 10 years from the date this chapter is adopted and the governing body passes the project participation agreement.

## § 33-11. Project participation agreement.

- A. The qualifying entity shall prepare with the City a project participation agreement. This agreement is the formal document, which states the contribution and obligation of all parties in the economic

development project. The agreement must state the following items:

- (1) The economic development goals of the project;
- (2) The contribution of the City and the qualifying entity;
- (3) The specific measurable objectives upon which the performance review will be read;
- (4) A schedule for project development and goal attainment;
- (5) The security being offered for the City's investment;
- (6) The procedures by which a project may be terminated and the City's investment recovered; and
- (7) The time period for which the county shall retain an interest in the project. Each project agreement shall have a "sunset" clause after which the City shall relinquish interest in and oversight of the project.

B. Each project participation agreement shall be subject to review and approval by the governing body at a public hearing.

### **§ 33-12. Project monies.**

All project monies shall be kept in a separate account by the entity and the City, with such account clearly identified. These accounts shall be subject to an annual independent audit.

### **§ 33-13. Termination.**

The governing body may terminate this chapter and the City's economic development plan and any or all project participation agreements undertaken under its authority. Termination shall be by ordinance at a public hearing or in accordance with the terms of the project participation agreement. If an ordinance or a project participation agreement is terminated, all contract provisions of the project participation agreement regarding termination shall be satisfied. Upon termination of the ordinance or any project participation agreement, any City monies remaining in the City project accounts shall be transferred to the City's general fund.

### **§ 33-14. Joint or regional projects.**

The City may engage in economic development projects involving one or more other government entities for projects, which encompass more than one municipality or county. In such instances, the relevant governing bodies shall adopt a joint powers agreement. This agreement will establish the application criteria and the terms of all project participation agreements. Criteria established under a joint powers agreement shall be consistent with the provisions of this chapter.

**Work Session**

**CITY COUNCIL MEETING AGENDA REQUEST**

**DATE:** December 28, 2016      **DEPT:** Community Development Dept.

**MEETING DATE:** January 11, 2017

**DISCUSSION ITEM/TOPIC:** Contract for Animal Welfare Coalition to service and staff the City of Las Vegas Animal Shelter.

**BACKGROUND/RATIONALE:** The Animal Welfare Coalition ("AWC") is a non-profit corporation whose purpose is to provide humane animal care and animal sheltering services. The City of Las Vegas seeks to enter into a contract with the AWC and has negotiated the terms of a contract to render humane animal care and animal sheltering services for the City of Las Vegas. The contract includes a scope of work, standards of care, types of and details of reports needed by the City, mutual goals for the community and animal safety, fee distribution and the maintenance of the City owned facility.

**THIS REQUEST FORM MUST BE SUBMITTED TO THE CITY CLERK'S OFFICE NO LATER THAN 5:00 P.M. ON FRIDAY ONE AND A HALF WEEKS PRIOR TO THE CITY COUNCIL MEETING.**



\_\_\_\_\_  
**SUBMITTER'S SIGNATURE**

**REVIEWED AND APPROVED BY:**



\_\_\_\_\_  
**TONITA GURULÉ-GIRÓN  
MAYOR**

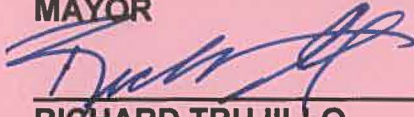

\_\_\_\_\_  
**RICHARD TRUJILLO  
CITY MANAGER**

\_\_\_\_\_  
**ANN MARIE GALLEGOS  
FINANCE DIRECTOR  
(PROCUREMENT)**

\_\_\_\_\_  
**PURCHASING AGENT  
(FOR BID/RFP AWARD)**

\_\_\_\_\_  
**H. CHICO GALLEGOS  
CITY ATTORNEY  
(ALL CONTRACTS MUST BE  
REVIEWED)**

01/03/17

**CONTRACT BETWEEN THE CITY OF LAS VEGAS, NEW MEXICO  
AND  
THE ANIMAL WELFARE COALITION OF NORTHEASTERN NEW MEXICO**

This contract entered into this \_\_\_\_\_ day of \_\_\_\_\_, 2017, and effective \_\_\_\_\_, 2017 thru June 30, 2018 between the City of Las Vegas, New Mexico, a municipal corporation, hereinafter called the "City" and the Animal Welfare Coalition of Northeastern New Mexico, with the principal address of PO Box 524, Las Vegas, NM 87701, a non-profit corporation, hereinafter called the "Contractor."

**WHEREAS**, the City owns the City of Las Vegas Animal Shelter building and grounds and is in need of animal care services; and

**WHEREAS**, the City desires to engage the Contractor to render humane animal care and animal sheltering services; and

**WHEREAS**, the Contractor provides humane animal care and animal sheltering services; and

**WHEREAS**, the City and Contractor agree that Contractor may use the animal shelter to provide services under a contract with the County of San Miguel in addition to the services provided hereunder pursuant to this agreement.

**WHEREAS**, the City of Las Vegas has enacted an Animal Ordinance and Resolution governing the care, animal control, and fees related to animals within the City of Las Vegas; and

**WHEREAS**, in the absence of direction under the City of Las Vegas Ordinance, State Statute exists; and

**WHEREAS**, the City and Contractor have identified and are committed to the following goals:

1. To register dogs within City limits in order for owner/guardians to be identified if an animal is lost or upon intake into the shelter.
2. To decrease the amount of dogs within City limits running at large.
3. To increase the number of dogs within City limits that have current rabies vaccinations and certificates.
4. To increase the amount of dogs and animals within the City of Las Vegas who are spayed and neutered in order to decrease over-population of dogs and cats.

**WHEREAS**, the City and Contractor wish to enter into this agreement; and

**WHEREAS**, the City in consideration of services rendered will provide financial support in an amount not to exceed One Hundred Eighteen Thousand and 00/100 Dollars (\$118,000.00) annually. Additionally, the city will pay utility costs including gas, solid waste, water, wastewater, and electricity (PNM) at the City of Las Vegas Animal Shelter. Contract will be prorated from the effective date of

contract through June 30, 2018; and shall be paid to the Contractor on a monthly basis under the terms and conditions of this Contract.

**NOW THEREFORE, THE PARTIES AGREE AS FOLLOWS:**

The City will pay on invoices presented under this Contract where work (described under Addendum A, Scope of Work attached hereto) has been completed and services have been provided to the City. The schedule for payment by the City of Las Vegas is net thirty (30) days. To be paid for any invoice, the Contractor must be current in reporting requirements. The requirements are as follows:

**A. SCOPE OF WORK**

See Addendum A, Scope of Work attached hereto.

**B. EXECUTION OF SCOPE OF WORK**

Contractor shall implement the Scope of Work as detailed in Addendum A.

**C. DELIVERABLES**

Contractor shall submit a deliverable implementation and financial report on a monthly basis for review and approval by the Community Development Director with a copy to the City Manager's office prior to the City making payment to the Contractor. A sample of which is shown in Addendum F. The report must include, but is not limited to, all activities conducted by the Contractor as outlined in the Scope of Work, and all revenues, grants, fee collections and expenditures, to include any revenues from sources other than the City.

**D. FINANCIAL REVIEW**

Contractor shall have a detailed financial review of all expenditures related to this contract during the contract. This review must be provided by an independent third party. Any costs for this review must be paid by Contractor; the cost of which may not exceed three percent (3%) of the contract amount.

**E. PAYMENT**

Payment to the Contractor shall be prorated from the effective date of contract through the end of the contract and will be made on a monthly basis based upon the scope of work, submittal of invoices and support documentation and the receipt of a deliverable implementation and financial report.

Invoices shall include (i) Contractor name and address, (ii) detailed description of the work performed or services acquired, (iii) the amount of payment requested, and (iv) a certification by an authorized officer of the Contractor as to the accuracy of statements set forth in the invoice. The Contractor shall submit reports and original invoices to the Community Development Department with a copy to the City Manager's office.

## **F. INSURANCE**

Contractor will furnish the City's Finance Director with a Certificate of Insurance prior to disbursement of any funds. The insurance shall cover any and all activities engaged in and sponsored by Contractor and shall name the City as an additional insured.

## **G. HOLD HARMLESS**

Contractor shall hold harmless, indemnify and defend the City and its "public employees" as defined in the New Mexico Tort Claims Act, Sections 41-4-1 to 41-4-29, NMSA 1978, as amended, against and from any and all claims losses, demands, judgments, damages, liabilities, lawsuits, expenses, attorney fees, and/or actions of any kind and nature, whether from death, bodily injury or damage to property resulting from, or related to, the Contractor's negligence or intentional acts, errors or omissions in the Contractor's performance under this Contract. The Contractor's agreement to hold harmless, indemnify and defend shall not be affected nor terminated by the cancellation or expiration of the term or any renewal or any other modification of this Contract for any reason, and shall survive the cancellation or expiration of the term or any renewal or any other modification of the Contract for negligence acts, errors or omissions to act occurring during the term of this Contract.

## **H. DISCLOSURE TO THE CITY**

Any additional means of funding to include contracts and/or sub-contracts held by the Contractor with other funding entities shall be disclosed to the City prior to the execution of this contract. In addition, at such times and in such form as the City Council may require, Contractor shall furnish to the City, such statements, records, reports, data and information as the City may request pertaining to matters covered by this Agreement.

## **I. NO FINANCIAL INTEREST**

No officer or employee of the City or of the Contractor who exercises any function of responsibility in connection with the planning and implementation of any of the provisions of this Contract shall have any direct personal financial interest in this Contract, and the Contractor shall take appropriate steps to assure compliance.

The City of Las Vegas and Contractor agree that the Shelter Director is a paid employee of the Contractor.

## **J. PREJUDICE**

No person, on account of race, color, religion, national origin or because of non-membership in the Contractor's organization shall be excluded from participating in, or denied benefits of any activity made possible through and resulting from this Contract.

**K. POLITICAL ACTIVITY**

None of the funds, materials, property or services rendered directly or indirectly under this Contract shall be used for any political activity, or to further the election or defeat of any candidate for state, federal or local office.

**L. ASSIGNMENT**

Contractor shall not assign any interest in this Contract, excluding payments for services by the Contractor, as provided for above and shall not transfer any interest in the same (whether by assignment or novation), without the prior written consent of the City thereto. Provided, however, that claims for money due, or to become due, to the Contractor from the City under this Contract may be assigned to a bank, trust company or other financial institution without such approval.

**M. SUBJECT TO LAWS**

Contractor shall comply at its own cost with all applicable laws, ordinances and codes of the federal, state and local governments. The City shall comply at its own cost with all applicable ordinances, laws, and codes of the federal, state, and local government regarding the building and grounds.

**N. NO FURTHER LIABILITY**

The City shall not be obligated or liable under this Contract to any party other than the Contractor for payment of any monies, to include payroll taxes or for provision of any goods or services unless such liabilities are specifically agreed to in this Contract.

**O. JURISDICTION**

It is mutually agreed by and between the parties hereto that this Contract shall be performed in Las Vegas, San Miguel County, New Mexico, and further that any legal action or causes of action in connection, herewith, will be within the jurisdiction of the appropriate court in San Miguel County, New Mexico, for all purposes.

**P. TERMINATION**

The City may, with or without cause, terminate this Contract at any time upon sixty (60) days written notice of termination given to the Contractor. Similarly, the Contractor may, with or without cause, terminate this Contract upon sixty (60) days written notice to the City. The City shall pay the Contractor for all services rendered by the Contractor through the termination date contained in the notice under the same terms and conditions stated elsewhere herein.

**Q. ENTIRE AGREEMENT**

This Contract constitutes the entire Contract between the parties hereto; any prior Contract, whether written or oral, or assertion or statement, or understanding or other commitment antecedent to the

Contract shall not have any force or effect whatsoever, unless the same is mutually agreed to by the parties hereto and reduced to writing. No changes or amendments to this Contract shall be effective except those on written approval by both parties.

#### **R. AMENDMENT**

This Contract will not be altered, changed or amended except by a written document signed by the parties to this Contract.

#### **S. AUTHORITY TO BIND THE CITY**

Contractor shall not have the authority to enter into any Contract/Agreement binding upon the City or to create any obligation on the part of the City, except such as shall be specifically authorized by the City's governing body or by the City Manager acting upon authority granted by the City's governing body.

#### **T. NOTICES**

Any notices required to be given under this Contract shall be deemed sufficient, if given in writing, by mail, to the principal office of the City or to the principal office of the Contractor.

#### **U. BRIBERY AND KICKBACKS**

As required by Section 13-1-191, NMSA 1978, as amended, it should be noted that it is a third degree felony under New Mexico Law to commit the offense of bribery of a public officer or public employee Section 30-24-1, NMSA 1978, as amended; it is a third degree felony to commit the offense of demanding or receiving a bribe by a public officer or public employee, Section 30-24-2, NMSA 1978, as amended; it is a fourth degree felony to commit the offense of soliciting or receiving illegal kickbacks, Section 30-41-1, NMSA 1978, as amended; it is a fourth degree felony to commit the offense of offering or paying illegal kickbacks, Section 30-41-2, NMSA 1978, as amended.

#### **V. NEW MEXICO TORT CLAIMS ACT**

Any liability incurred by the City of Las Vegas in connection with this Agreement is subject to the immunities and limitations of the New Mexico Tort Claims Act, Section 41-4-1, et. seq. NMSA 1978, as amended. The City and its "public employees" as defined in the New Mexico Tort Claims Act, do not waive sovereign immunity, do not waive any defense and do not waive any limitation of liability pursuant to law. No provision in this Agreement modifies or waives any provision of the New Mexico Tort Claims Act.

#### **W. THIRD PARTY BENEFICIARIES**

By entering into this Agreement, the parties do not intend to create any right, title or interest in or for the benefit of any person other than the City and the Contractor. No person shall claim any right, title or interest under this Agreement or seek to enforce this Agreement as a third party beneficiary under this Agreement.



**X. TERM**

The term of this Contract will be **January \_\_, 2017 thru June 30, 2018.** Should the Contractor wish to renew this Contract, the Contractor must provide written notice to the City at least ninety (90) days prior to the anniversary date.

**Y. OVERSIGHT**

Once every six months (6) a public meeting jointly hosted by Contractor and City shall be held to present progress, status of shelter and allow for public input. After such meeting the City and Contractor shall meet to identify priorities and any appropriate action steps.

**SIGNED:**

\_\_\_\_\_  
Richard Trujillo, City Manager

\_\_\_\_\_  
Animal Welfare Coalition

**REVIEWED AND APPROVED AS TO LEGAL SUFFICIENCY:**

\_\_\_\_\_  
H. Chico Gallegos, City Attorney

**ATTEST:**

\_\_\_\_\_  
Casandra Fresquez, City Clerk

## Addendum A Scope of Work

1. The parties hereto do mutually agree as follows:
  - a. City of Las Vegas Animal Code, Chapter 118 (Addendum B), Recommended Minimum Standards for Animal Shelters in New Mexico (Addendum C), City of Las Vegas Resolution Number 16-22 (Addendum D), Maintenance Procedures (Addendum E), Sample Animal Welfare Coalition Report (Addendum F), and Collection, Retainment and Use of Fees (Addendum G) are incorporated herein and shall act as a guide for the standards and outcomes desired under scope of work and conduct in administering the care contracted herein.
  - b. A full inventory of City and Contractor supplies and equipment shall be completed and a comprehensive visual inspection of premises shall be conducted prior to execution of this Contract. Equipment inventoried as property of the City will stay for use by the Contractor. Any additional equipment or supplies added by the Contractor over the term of services will go with the Contractor whenever services are ended by termination or non-renewal of this Contract.

The Contractor shall:

2. Operate the City of Las Vegas Animal Shelter for animals impounded by the City, surrendered by City residents (as shelter space permits) and/or brought in as strays. The Contractor shall be accessible to the City twenty-four (24) hours per day throughout the term of this agreement pursuant to City of Las Vegas Animal Code.
3. Provide a quarantine area for animal(s) who exhibit symptoms of disease or conditions such as rabies or any other dangerous disease pursuant to City of Las Vegas Animal Code.
4. Maintain a documented, comprehensive standard intake procedure.
5. Visually examine all animals upon intake, provide identification and wellness vaccinations to healthy non fractious animals and provide stabilization and wellness of care as needed.
6. Hold animals impounded by the City for the length of time specified and or required by the City of Las Vegas Animal Code if applicable.
7. Provide daily care to animals according to the Recommended Minimum Standards for Animal Shelters in New Mexico, Addendum C, incorporated herein.
8. Provide medical care under the direction and authority of a licensed Veterinarian(s) and shall maintain detailed records of such, date, time, description of the animal and breed, name of Veterinarian, date, time and outcome/disposition of animals. Decisions regarding all medical care, including treatment of animals rest with the Contractor and a board certified, licensed Veterinarian. Contractor will provide the name(s) of all such providers to the City of Las Vegas. The cost of any/all veterinary services rests solely with Contractor.

9. Decisions regarding medically necessary euthanasia of suffering animals impounded at the Las Vegas Animal Shelter rest with the Contractor and a licensed veterinarian.
10. Be responsible for the storage and disposal of remains of animals (by mass cremation) received which are euthanized, brought to the shelter deceased, or other. The Contractor shall provide and maintain a freezer on the premises for the appropriate storage of the remains of all dead animals, prior to their disposal.
11. Contractor's staff and volunteers shall conduct themselves professionally and courteously at all times.
12. Develop and maintain a written standard operating procedure for determining the humane disposition for any animal not reclaimed by its guardian and the final disposition of all animals that are not designated by the City as "Do Not Release," "Hold for Court," or "Do Not Euthanize."
13. Contractor will abide by all the documents incorporated herein, state and federal laws and procedures regarding a person's right to property.
14. Contractor shall use all reasonable means to determine the identity/owner of the animal and notify the owner of the animal's location.
15. Vaccinations shall be given in compliance with industry standards, including those in Addendum C incorporated herein.
16. Contractor shall assess fees pursuant to City of Las Vegas Animal Code, Chapter 118 (Addendum B) and Resolution 16-22 (Addendum D) both incorporated herein. Fees pertaining to cremation, licensing and impound will be paid to the City and owners will be referred to the City of Las Vegas cashier's office for collection of said fees.
17. Contractor will use the crematory in an efficient manner according to the documented guidelines for make and model of the crematory.
18. Contractor shall maintain premises in a professional, clean and well kept manner and conduct cleaning of pipes/drains according to the specifications and schedule (Addendum E) incorporated herein and shall maintain records of such. The City reserves the right to have its' Building Inspector or other designee inspect for all maintenance of building and cleaning of pipes and drains and the Contractor's staff or a member of the AWC will be present during inspection.
19. The City reserves the right to appear without notice and inspect the Contractor's work in performance of duties under this Contract. The City shall retain copies of all keys, not including those for narcotics storage and shall be provided with the names and contact information of any persons having keys to the building and who shall administer narcotics. Contractor's staff or a member of the AWC will be present during inspection.
20. The City may agree to act as a fiscal agent when necessary for the purpose of acquiring grant funding; such agreement shall be in writing.
21. Matters involving bites, vaccinations, hold cases and protective custody shall be in accordance with City of Las Vegas ordinance.
22. Contractor shall not subcontract any portion of the services to be performed under this Agreement without the prior written approval of the City.

23. Contractor, and his/her agents and employees are independent contractors performing professional services for the City and are not employees of the City. The Contractor, and his/her agents and employees, shall not accrue leave, retirement, insurance, bonding, use of City vehicles, or any other benefits afforded to employees of the City as a result of this Agreement.
24. Contractor shall provide monthly status reports to the City that include the following information in addition to the reports recommended in Addendum C:
  - a. Admission date, time and breed of animal (s) brought into the Las Vegas Animal Shelter.
  - b. The method by which animal was received (City Animal Service Officer, Citizen, or other manner) to be detailed.
  - c. The total number and types of animals brought to shelter.
  - d. Detail of services rendered.
  - e. Discharge date, time, ultimate outcome (adoption, return home, medically treated, euthanized or detailed other).
  - f. Detailed Financial report of all revenues collected, detailed expenditures disbursed, grant funds received, donation and details of types of fees assessed.
  - g. Further documentation of services rendered will be available upon request.
  - h. Contractor shall maintain detailed in-depth records with regards to the keeping and administration of any Controlled Substances. Records shall include the name of animal, name of controlled substance, date, time, and dosage of controlled substance.
25. The City will be available to the Contractor Monday through Friday during business hours for any matters regarding actions to be taken by the City of Las Vegas Animal Shelter, including any repairs, maintenance, alterations, or reconstruction of the facility. The City will provide building and grounds repair and maintenance, including, but not limited to plumbing and any equipment owned by the City on shelter grounds that is used by the Contractor in providing services called for in this Contract.
26. In the case of emergency repairs/services, the Contractor shall immediately notify the City. In the case of an emergency, the City will provide an on-call contact for the Contractor to use.
27. Only in the case of an emergency will the City use keys to the City of Las Vegas Animal Shelter without a member of the AWC or the Pet Center staff present. The Contractor shall be provided with the names and contact information of all persons having keys to City of Las Vegas Animal Shelter.
28. Contractor will have the use of the property from the fence behind the City of Las Vegas Animal Shelter to Grand Avenue.

**Addendum B**

**City Ordinance Chapter 118 Animals**

## Chapter 118. Animals

[HISTORY: Adopted by the City Council of the City of Las Vegas as Ch. 9, Art. 8 of the 1972 City Code. Amendments noted where applicable.]

### **GENERAL REFERENCES**

Code enforcement citations and penalty assessments — See Ch. 179.

## Article I. Title; Purpose; Definitions

### § 118-1. Short title; purpose of chapter.

- A. This chapter shall be known and may be cited as the "Las Vegas Animal Control Ordinance."
- B. It is the intent of the City Council that enactment of this chapter will protect animals from cruelty, neglect, and abuse, protect residents from annoyance and injury, assist in providing housing for animals in a control center, finance the functions of licensing and recovery and establish a program for sterilization of animals.

### § 118-2. Definitions.

[Amended 6-16-1994 by Ord. No. 82-3]

As used in this chapter, the following terms shall have the meanings given herein:

#### **ANIMAL**

Any vertebrate member of the animal kingdom excluding human beings.

#### **ANIMAL CONTROL SHELTER**

A facility designated by the City of Las Vegas for the humane treatment of animals pursuant to the provisions of this chapter.

#### **ANTI-ESCAPE**

Any housing, fencing or device which the guard dog cannot go over, under, through or around.

#### **BITE**

Any actual puncture or tear of the skin inflicted by the teeth of an animal.

#### **CITY**

The City of Las Vegas, a municipal corporation.

#### **COMMERCIAL PROPERTY**

- A. A portion of land and/or buildings zoned for or utilized for commercial or business uses in the City of Las Vegas, including temporary sites.
- B. Any vehicle utilized for commercial or business purposes in the City of Las Vegas.

#### **DANGEROUS ANIMAL**

Any of the following:

- A. An animal which, when unprovoked, engages in behavior that requires a defensive action by a person to prevent bodily injury to a person or animal when the person and the animal are off the property of the owner of the animal; or
- B. An animal which, when unprovoked, injures a person and the injury results in muscle tears or disfiguring lacerations, or requires multiple sutures, or corrective or cosmetic surgery; or
- C. An animal which, because of its poisonous bite or sting, would constitute a significant hazard to the public.

**DESIGNATED AREA**

An area of private land which is determined by a property owner to house animals under the provisions of this chapter.

**ENCLOSED LOT**

Parcel of land or portion thereof in private ownership around the perimeter of which a wall or fence has been erected.

**ESTABLISHMENT**

A place of business together with its grounds and equipment.

**ESTRAY**

Any animal found running at large beyond the boundaries of the premises of the owner.

**GROOMING PARLOR**

Any establishment, or part thereof, or premises maintained for the purpose of offering animals cosmetological services for profit.

**GUARD DOG**

Any dog that is utilized to protect commercial property, as defined herein.

**HANDLER**

A person who is responsible for and capable of controlling the operations of a guard dog.

**HOBBY BREEDER**

A person involved in showing or controlled breeding of dogs and cats which are registered with a nationally or internationally recognized animal registry organization.

**HOUSING**

Any location where the guard dog is kept when not utilized for protection purposes.

**IMPOUND**

To take up an animal.

**KENNEL**

Any commercial establishment or premises where 10 or more dogs or cats over three months of age are boarded, kept or maintained for any purpose whatsoever, with the exception of state inspected veterinary hospitals and shelters.

**LICENSED VETERINARIAN**

A person with a doctor of veterinary medicine degree licensed to practice in the state.

**NUISANCE**

Means, but is not limited to, defecation, urination, disturbing the peace, emitting noxious or offensive odors or otherwise endangering or offending the well-being of the inhabitants of the City of Las Vegas.

**OWNER**

The owner of an animal is a person who owns, harbors or keeps, or knowingly permits an animal to be harbored or kept, or has an animal in his care, or who permits an animal to remain on or about his premises.

**PERSON**

Any individual, household, firm, partnership, corporation, company, society, association, and every officer, agent or employee thereof.

**PET SHOP**

Any commercial establishment or premises or part thereof maintained for the purchase, sale, exchange or hire of animals of any type; except that the term shall not include livestock auctions.

**PREMISES**

A parcel of land and the structures thereon.

**QUARANTINE**

To detain or isolate an animal suspected of having a contagious disease.

**REFUGE**

An establishment owned or operated by a nonprofit organization whose sole function is to aide and comfort more than four but not more than 12 animals.

**RUN or RUNNING AT LARGE**

To be free of physical restraint beyond the boundaries of the premises of the owner.

**SHELTER**

Any establishment owned and operated by a nonprofit humane organization licensed to do business in the state.

**VACCINATION**

Protection provided against rabies by inoculation with antirabies vaccine recognized and approved by the state.

**VICIOUS ANIMAL**

Any animal which shall bite or in any other manner attack or attempt to attack any person, except that any animal that bites, attacks, or attempts to attack any person unlawfully upon its owner's or keeper's premises, or which is provoked to attack, shall not be deemed a vicious animal.

**WILD OR EXOTIC ANIMAL**

Any animal not normally considered domesticated and shall include, but not be limited to:

- A. Class Reptilia; Order Phidia (such as racers, boas, water snakes, and pythons) and Order Loricata (such as alligators, caymans and crocodiles);
- B. Following members of the Class Aves: Order Falconiforms (such as hawks, eagles and vultures) and Subdivision Ratitae (such as ostriches, rheas, cassowaries and cmus);
- C. Class Mammalia: Order Carnifora, Family Felidae, (such as ocelots, margays, tigers, jaguars, leopards and cougars) except commonly accepted domesticated cats, the Family Canidae, (such as wolves, dingos, coyotes and jackels, except domesticated dogs) Emily Mustelidac, (such as kangaroos and common opossums), Order Edentata (such as sloths, anteaters and armadillos), Order Proboscidea (elephants), Order Primata (such as monkeys, chimpanzees and gorillas), Order Rodenta (such as porcupines) and Order Ungulata (such as antelope, deer, bison, and camels).

## Article II. Administration

### § 118-3. Powers and duties of City Manager.

The City Manager is responsible for the administration of this chapter. Reasonable rules and regulations shall be prescribed by the City Manager to carry out the intent and purpose of this chapter pursuant to the standards created by this chapter. Powers delegated to the City Manager may be delegated by the City Manager to his duly appointed animal control officers as he may deem expedient for the effectuation of this chapter.



## **§ 118-4. Impoundment of animals.**

It is the duty of the animal control officers to take up and impound any stray or any animal kept or maintained contrary to this chapter.

## **§ 118-5. Surrender of strays; disposition of animals; costs; records.**

[Amended 4-17-1997 by Ord. No. 85-25]

- A. No person shall, without the knowledge or consent of the owner, hold or retain possession of any animal of which he is not the owner, for more than 24 hours without first reporting the possession of an animal to the Police Department, giving his name and address, a true and complete statement of the circumstances under which he took up the animal, a description of the animal and the precise location where such an animal is confined.
- B. It is unlawful for a person taking up an animal to fail to give the notice required above and for any person having such animal in his possession to fail or refuse to immediately surrender such animal to the City or his designee upon demand thereof.
- C. An stray may be confined at the Animal Control Shelter for a period of at least three working days, during which time the City will make a reasonable attempt to notify the owner, if known. If identification of the owner is not possible, the City may, without notice, dispose of any stray impounded under this section. After the impoundment period, the City may place the animal in an adoptive home, if possible, or may destroy the animal in a humane fashion, including but not limited to cremation.
- D. No animal that has been impounded by the City will be adopted out for the purpose of breeding or sale. Every dog and cat adopted from the Animal Control Center shall be neutered or spayed by a licensed veterinarian and vaccinated in compliance with state statutes. The cost of these activities shall be paid to the City by the person adopting the dog or cat prior to release of the animal. Neutering and spaying and vaccinations will not apply to animals which are less than five months old. Nothing in this section shall be construed as applicable to any dog or cat returned to the owner thereof.
- E. Any stray animal, equine, ovine, porcine, or caprine animal which cannot be adopted may be destroyed. Any other stray not redeemed by its owner or placed with a new owner may be disposed of by the City, at its discretion.
- F. It shall be the responsibility of an animal owner redeeming an animal legally impounded to pay for animal boarding and other costs. The City of Las Vegas shall establish, by resolution, appropriate fees. In addition, the owner shall pay any license fees due, cost of inoculations or other costs incurred in the care and maintenance of said animal.
- G. The City shall maintain records for a reasonable period of time as determined by the City Manager of all animals impounded in the shelter. The record shall contain at least the following information:
  - (1) A complete description of the animal;
  - (2) The manner and date of its acquisition by the center;
  - (3) The date and manner of its disposal;
  - (4) The name and address of the purchaser of any animal; and
  - (5) All fees received.

## **§ 118-6. Cremation and disposal of impounded animals.**

[Amended 4-17-1997 by Ord. No. 85-25]

It shall be the responsibility of the City of Las Vegas to dispose of any animal by the use of an incinerating device. This is to assure a humane disposal procedure and assure a healthy environment. The City of Las Vegas shall establish, by resolution, appropriate fees. Payment for disposal through cremation, whether at the owner's personal request, or through enforcement of §§ 118-4 and 118-5, will be the responsibility of the owner per the following fee schedule:

- A. If an individual, laboratory, or business has a small animal which belongs to it which has been impounded and desires to have the same disposed of by cremation, the fee shall be \$30.
- B. If an individual, laboratory, or business has a large animal which belongs to it which has been impounded and desires to have the same disposed of by cremation, the fee shall be \$100.

## **Article III. Owner's Duties**

### **§ 118-7. Rabies vaccinations.**

- A. It is the duty of all persons owning or keeping a dog or cat over the age of five months to have such animals vaccinated against rabies. The rabies vaccination shall be given in an amount sufficient to provide immunity from rabies for one year and shall be administered by a licensed veterinarian. A certificate from a licensed veterinarian shall be evidence of vaccination. The City may require other animals to receive annual rabies vaccination. The veterinarian administering antirabies vaccine to any animal shall issue to the owner or keeper of the animal a numbered vaccination certificate. The certificate shall contain the name and address of the owner or keeper of the animal, a description of the animal vaccinated, the date of vaccination and the expiration date of the period of immunity.
- B. It is unlawful for the owner or keeper of any dog or cat to fail to exhibit its certificate of vaccination upon demand by the City.

### **§ 118-8. Rabid animal.**

An animal that has rabies or shows signs of having rabies and every animal bitten by another animal afflicted with rabies or that has been exposed to rabies shall be confined at once in a secure place by the owner. A person who knows or who has reason to know that an animal is infected with rabies or has been exposed to rabies shall immediately upon learning of the infection notify the City and the State Health Department as to the place where the animal is confined and shall surrender said animal to the Animal Control Officer upon demand. The City shall then deal with the rabid animal pursuant to state law.

### **§ 118-9. Dog bites.**

- A. The owner of an animal that bites a person and a person bitten by an animal shall report that occurrence to the City and the State Health Department within 24 hours. The owner of an animal that bites a person shall surrender said animal to the Animal Control Officer if the City deems it necessary to impound said animal for a period of observation.
- B. A physician who renders professional treatment to a person bitten by an animal shall report that fact to the City and the State Health Department within 24 hours of his first professional attendance. The physician shall give the name and address of the owner of the animal that inflicted the bite, if known, and any other facts or details that may assist the City in ascertaining the immunization status of the animal.
- C. Home confinement.
  - (1) An animal that bites a person shall be confined securely at a place and for a period of time deemed necessary by the City. The owner of the animal shall bear the cost of confinement. The City may consent to confinement on the owner's premises but only if the animal had a current rabies vaccination at the time the bite was inflicted. The premises where the home confinement is to occur shall be inspected and

approved for such purposes by an Animal Control Officer. The owner of the animal shall be required to enter into an indemnity agreement on a form approved and prescribed by the City before consent may be given for such home confinement.

- (2) A person who has custody of an animal that has bitten a person shall immediately notify the City if the animal shows any signs of sickness, abnormal behavior or if the animal escapes confinement. If the animal dies while it is in confinement, the person having custody of the animal shall notify the City or an animal control official and relinquish any claims to said animal.

## **§ 118-10. Restraint of animals.**

It is unlawful to permit dogs in the streets or public places unless on a secure leash and under the immediate physical control of the person having custody thereof.

## **§ 118-11. Confinement of female dogs or cats in mating season.**

Any person in control of a female dog or cat in mating season shall confine the dog or cat as to preclude other dogs or cats from either attacking or being attracted to such female animal.

## **§ 118-12. Dog licenses; fees.**

- A. Any person owning, possessing or harboring any dog five months of age or over shall obtain a license for such animal. Written application for such license shall be made on such forms as supplied by the City and shall state any information deemed necessary by the City. A current rabies vaccination certificate shall be presented at the time of the application for license. The license fee (tag and certificate) for this section shall be \$2 for a neutered animal and \$5 for an unneutered animal. In the event a tag is lost, replacement tags costing \$1 shall be purchased. The license shall expire December 31, of each year.
- B. A current license tag shall be affixed to the licensed dog at all times in a reasonable manner unless the licensed dog is being kept in an approved kennel, veterinary hospital, is appearing in an approved show or is being trained; provided that the person who is training a dog shall have in his personal possession the valid license tag for each dog and shall immediately display such upon request by an animal control officer, animal shelter personnel or other law enforcement officer.
- C. Animals belonging to nonresidents who do not keep said animals within the corporate limits of the City of Las Vegas for 30 consecutive days shall be exempt from this section; provided, however, that all the other provisions of this chapter must be complied with.
- D. The license fees shall not apply to dogs trained to assist and in fact are used to assist the blind or deaf.

## **§ 118-13. Space requirements.**

- A. Animals shall be allowed in designated areas in the following ratios:
  - (1) A maximum of:
    - (a) Cow: one per 1/2 acre.
    - (b) Horse: one per 1/2 acre.
    - (c) Sheep: one per 1/3 acre.
    - (d) Goat: one per 1/3 acre.
    - (e) Pig: one per 1/4 acre.

- (f) Chicken: one per 200 square feet.
  - (g) Duck: one per 200 square feet.
  - (h) Goose: one per 200 square feet.
  - (i) Rabbits: one per 200 square feet.
- B. The area must be fenced to prevent the animal from leaving the designated area.
  - C. The designated area must be at least 50 feet from any residential structure or commercial business not owned and inhabited by the owner of the animals.
  - D. The designated area must be kept clean of animal waste or other material which may attract flies or emit obnoxious odors.

## **§ 118-14. Number of animals permitted.**

[Added 6-16-1994 by Ord. No. 82-3]

- A. No household or member thereof is allowed to own, harbor or keep dogs or cats, or any combination thereof, totaling more than four animals, consisting of animals subject to the licensing requirements of § 118-12; provided that any household owning dogs or cats or any combination therefor totaling more than four animals, which animals are licensed before the effective date of this section, shall be allowed to retain more than four animals only as long as the particular animals owned on the effective date remain in the possession of said household; provided, further, that the head of any household shall be held responsible for any violation of this section by the household or any of its members.
- B. Any household or member thereof owning, harboring or keeping more than four dogs or cats on the date that this provision becomes effective shall be permitted to own, harbor or keep such number of animals upon the following conditions:
  - (1) That the owner, within 30 days after the effective date hereof, report in person to the Animal Control Center a description of such animals.
  - (2) That all such owners, within 30 days after the effective date hereof, show proof of compliance with § 118-7, Rabies vaccinations, and § 118-12, Dog licenses; fees.

## **§ 118-15. Professional animal permit required for kennels, pet shops, hobby breeders, certain shelters and related businesses.**

[Added 6-16-1994 by Ord. No. 82-3]

The City Council hereby declares it to be conducive to the promotion of the health and general welfare of the inhabitants of this City to require a professional animal permit to operate a kennel, grooming parlor, pet shop, refuge or shelter or to be a hobby breeder and impose certain regulations and inspection fees on those engaged in operating, maintaining or owning a kennel, grooming parlor, refuge or shelter or pet shop, or being a hobby breeder.

- A. Kennels, grooming parlors, pet shops, refuges, hobby breeders and shelters shall be allowed only in zones designated by Chapter 450, Zoning.
- B. Procedures for obtaining a professional animal permit; fees and renewals.
  - (1) Persons operating kennels, grooming parlors or pet shops or hobby breeders shall obtain a professional animal permit.
  - (2) An application for a professional animal permit shall be filed on forms provided by the City Manager.
  - (3) Each application for a professional animal permit must include a petition on forms provided by the City signed by the residents and owners of all property, abutting the property for which the permit has been

requested, not including public right-of-way, stating that said residents and property owners have no objection to the permit being issued. The person applying for the permit is responsible for obtaining the signatures. Provided, however, that the applicant may submit a petition not signed by all abutting resident and property owners if he is unable to obtain their signatures, and said petition must give the names and addresses of the residents and property owner who have not signed. The City Manager may contact any of the abutting residents or property owners to discuss the application.

- (4) Within 30 working days of receipt of an application for any professional animal permit, the City Manager shall inspect the premises to determine whether they comply with the standards established by this chapter.
- (5) The City Manager shall conduct a public hearing on each application for a professional animal permit for a refuge. At least 15 days before the date of this hearing, the applicant must post and maintain one or more signs as provided and where instructed by the City Manager. It is unlawful for any person to remove or tamper with any such required sign during the period it is required to remain under this subsection. The City Manager shall notify the applicant by mail of the date, time, and place of hearing and shall also mail written notices not less than six days prior to the date of the hearing to all owners of property within 100 feet of the exterior boundaries of the property which is the subject of the application, using for this purpose the last known name and address of the owners shown in the records of the San Miguel County Assessor.
- (6) Within 30 working days after the inspection required for any professional animal permit or the public hearing on an application for a refuge, the City Manager shall approve, approve with conditions, or deny the professional animal permit application. The City Manager shall approve an application if he determines that:
  - (a) The standards established by this chapter, by Chapter **450**, Zoning, and other applicable laws and regulations are met.
  - (b) The activity would not be detrimental to the public welfare.
  - (c) The professional animal permit would not be injurious to the neighborhood. In making his decision, the City Manager shall assess neighborhood input from public hearing for refuges, the petition for hobby breeders or any complaints which have been made against the refuge or hobby breeder to determine the seriousness of any objections, but neighborhood input shall not be the sole determinant of his decision.
- (7) Should the applicant for any professional animal permit, any party in the public hearing required for a permit for refuge, or any resident or property owner residing or owning property which abuts the premises of a hobby breeder wish to appeal the City Manager's decision, such appeal must be made to the City Council.
- (8) If the professional animal permit application is approved by the City Manager, the applicant shall pay a permit fee of \$25 and the permit shall be issued; provided, however, that shelters shall be exempt from this fee and applicants for hobby breeder may either purchase a regular license as provided in § **118-12** or pay a fee of \$25 for the professional animal permit. New professional animal permits for kennels, grooming parlors, pet shops or animal shelters, but not a renewal, shall be issued with permit fees prorated on a semiannual basis. Except for refuges, professional animal permittees who keep their animals confined shall, at the option of the permittee, be exempt from the animal license requirements of this chapter, and will not be issued any license tags unless the required animal license fee is paid; provided that hobby breeders who are professional animal permittees will be issued license tags when the required fee for the professional animal permit is paid, but will be exempt from the animal license requirements as provided in § **118-12** for each animal on the premises.
- (9) Professional animal permits are not transferable from one person to another person or place. A valid permit shall be posted in a conspicuous place in every kennel, grooming parlor, pet shop, refuge and shelter.
- (10) A professional animal permit holder shall notify the City Manager of any change in his operation which may affect the status of his permit and shall keep the City Manager apprised of any changes in name or

location of the activities covered by the permit.

- (11) Persons in charge of any kennel, grooming parlor, pet shop, refuge or shelter and any hobby breeder shall be responsible for complying with this chapter. There shall be kept at each kennel, grooming parlor, pet shop, refuge or shelter, and hobby breeder's premises a record of all animals received and of their final disposition.
- (12) The professional animal permit for kennels, grooming parlors, pet shops, and animal shelters shall expire December 31 of each calendar year, and an application for renewal shall be filed by February 1 of the following year. The professional animal permit for hobby breeders and refuges shall expire one year after the date of issuance, and an application for renewal shall be filed within 30 days after the date of expiration. Procedures and fees for permit renewals shall be the same as those for new applications, except the public hearing for professional animal permits for refuges shall not be required.

C. Facilities and care applicable to professional animal permit.

- (1) Animal housing facilities shall be constructed of nontoxic materials and in a structurally sound design. Interior floors shall be smooth, easily cleanable construction and impervious to water. The facility shall be kept in good repair and kept clean and sanitary at all times, so as to protect animals from disease and injury.
- (2) Housing requirements.
  - (a) Animals maintained in pens, cages or runs for periods exceeding 24 hours shall be provided with adequate space to prevent overcrowding and to maintain normal exercise according to species.
  - (b) Indoor housing shall be provided for in all pet shops, grooming parlors, refuges, shelters and commercial kennels. These facilities shall be sufficiently temperature controlled and ventilated to provide for the animals' comfort and health.
  - (c) Sufficient lighting shall be provided by either artificial or natural means.
  - (d) Outside housing shall be sufficient to protect animals from sunlight, rain, snow or cold weather that may be detrimental to the animals' health.
  - (e) Provisions shall be made for the removal and proper disposal of animals and food waste, bedding, dead animals and debris. Disposal facilities shall be provided and so operated as to minimize vermin infestation, odors, and disease hazards.
- (3) Adult animals shall be segregated by sex, except where otherwise indicated for health, welfare or breeding purpose, and any vicious or quarantined animals shall be removed and caged by themselves. Provided, however, that hobby breeders shall not be required to segregate the animals by sex.
- (4) Except as indicated for health or welfare, animals shall be provided with clean, fresh, sufficient and wholesome food and water. Food and water containers shall be kept clean.
- (5) Each animal shall be observed daily by the animal caretaker in charge or his representative. Sick, diseased, injured, lame or blind animals shall be provided with proper veterinary care. Any person operating or employed at a kennel, grooming parlor, pet shop, refuge, or shelter who observes an animal which he suspects of being rabid shall at once notify the City Manager and the State Department of Health and Social Service and segregate such animal(s) for a period of 10 days unless examined and released by written statement of a veterinarian and then only at the discretion of the City Manager.
- (6) Persons operating kennels, grooming parlors, pet shops, refuges and shelters as well as hobby breeders shall comply with all applicable requirements under this chapter.
- (7) Refuges shall be required to have all their dogs and cats spayed or neutered; provided, however, that this requirement does not apply to the four dogs or cats permitted per household by § 118-14 of this chapter.

D. Inspection under a professional animal permit. The City Manager or his designee, after proper identification, shall be permitted to enter, at any reasonable time, any kennel, grooming parlor, pet shop, refuge, or shelter, or hobby breeder premises for the purpose of making inspections to determine compliance with this chapter. The

City Manager, or his designee, shall make as many inspections and reinspection as are necessary for the enforcement of this chapter.

E. Number of animals permitted holders of a professional animal permit for hobby breeders.

- (1) The number of adult dogs or cats, or any combination thereof, which any holder of a professional animal permit for hobby breeder may keep shall be limited on the basis of the allowable kennel area which he has and an area requirement per dog or cat. "Allowable kennel area" is defined as 10% of the total area of the lot on which the hobby breeding is to be conducted. The area requirement per dog or cat is established from the following table:

<b>Animal Size (pounds)</b>	<b>Area Required (square feet)</b>
Small (under 30 pounds)	75
Medium (30 to 59 pounds)	100
Large (60 pounds or more)	125

- (2) "Animal size" is defined by the weight specified in the standard for the breed, either average or maximum allowable. If no breed standard for weight exists, the City Manager shall set a weight standard for the purposes of this subsection. The sum of the area requirement for each dog or cat which the hobby breeder keeps cannot exceed the allowable kennel area.

## Article IV. Animal Control

### § 118-16. Animals running at large.

[Amended 6-16-1994 by Ord. No. 82-3]

It is unlawful for any person to allow or permit any animal to run at large in or upon any street, alley, sidewalk, vacant lot, public property, other enclosed place in the City or private property not belonging to owner of animal. Any animal permitted to run at large in violation of this section is declared to be a nuisance, a menace to the public health and safety and shall be taken up and impounded as provided in § 118-4.

### § 118-17. Animals on unenclosed premises.

It is unlawful for any person to chain, stake out, graze or herd any animal on any unenclosed premises in such a manner that such an animal may go beyond the designated area.

### § 118-18. Vicious animals.

It is unlawful for any person to keep or harbor any vicious animal. Any person attacked by a vicious animal while on public property may use reasonable force to repel said attack. After a judicial determination that an animal is vicious, the owner or keeper of such vicious animal shall destroy it humanely or turn such animal over to the City for destruction.

### § 118-19. Dangerous animals.

[Added 6-16-1994 by Ord. No. 82-3]

No person shall maintain a dangerous animal in a manner which constitutes a threat to any person or other animal.

### § 118-20. Animals disturbing the peace.

It is unlawful for any person to allow any animal to persistently or continuously bark, howl or make noise common to their species, or otherwise to disturb the peace and quiet of the inhabitants of the City of Las Vegas, or to keep or maintain animals in such a manner as to disturb by noxious or offensive odors, or otherwise endanger the health and welfare of another person.

### **§ 118-21. Nuisances.**

It is unlawful for the owner of any animal to permit, either willfully or through failure to exercise due care or control, any such animal to commit any nuisance upon any property other than the owners of the animal, and then only so long as no other provision of this chapter is violated.

### **§ 118-22. Unlawful use of license tags.**

It is unlawful for any person to remove any license tag from one animal to another or to remove a license tag from an estray without lawful permission. It is unlawful for any person to manufacture or cause to be manufactured or to have in his possession or under his control, a stolen, counterfeit, or forged animal license tag, rabies vaccination certificate or other form of animal or premises licensing.

### **§ 118-23. Breaking into animal control center, shelter or animal control vehicles.**

It is unlawful for any person to break open any pound, center, or animal control vehicle wherein animals are impounded by the City of Las Vegas or in any other way to remove or assist in the removal of any animal from such pound, center or vehicle without lawful permission.

### **§ 118-24. Dogs trained to assist the blind or deaf in public places.**

It is unlawful for any person owning, operating or maintaining any public place of business or conveyance into which the general public is invited for any business purpose to debar or exclude therefrom any dog which has been trained to assist the blind or deaf, provided that such dog be in the company of the blind or deaf person whom it was trained to assist in conformance with the law.

## **Article V. Cruelty to Animals**

### **§ 118-25. Physical abuse.**

[Amended 6-16-1994 by Ord. No. 82-3]

- A. It is unlawful for any person to willfully or maliciously kill, maim, disfigure, torture, kick, beat with a stick, chain, club or other object; mutilate, burn or scald with any substance, any animal, except that reasonable force may be employed to drive off vicious or trespassing animals.
- B. It is unlawful for any person to carry any animal in or upon any vehicle in a cruel, inhumane, or unsafe manner. No person shall keep or transport an animal in the bed of a pickup truck unless the animal is properly restrained in a humane and safe manner to prevent the animal from leaving the confines of the bed of the truck when the vehicle is stationary and to prevent the animal from falling off while the vehicle is in motion. No person shall leave an animal in a closed vehicle for any length of time reasonably concluded to be dangerous to the health or safety of the animal.

### **§ 118-26. Work cruelty.**



It is unlawful for any person to drive or work any animal cruelly.

## § 118-27. Neglect.

It is unlawful for any person to fail, refuse or neglect to provide any animal in his charge or custody, as owner or otherwise, with proper food, drink, shade, care or shelter, or to carry an animal in or upon any vehicle in a cruel or inhumane manner. Any animal habitually kept outside shall be provided with a structurally sound, weatherproof enclosure, large enough to accommodate the animal.

### § 118-27.1. Anti-tethering of canines.

[Added 2-15-2012 by Ord. No. 12-02<sup>[1]</sup>]

Supervision, protection and continuous confinement and tethering of canines.

- A. As used in this section, "tether" means to restrain a canine by tying the canine to any object or structure, including without limitation a house, tree, fence, post, garage, or shed, by any means, including without limitation a chain, rope, cord, leash, or running line. Tethering shall not include using a leash to walk a canine.
- B. It shall be unlawful for a responsible party to tether a canine while outdoors, except when all of the following conditions are met:
- (1) The canine is in visual range of the responsible party, and the responsible party is located outside with the canine.
  - (2) The tether is connected to the canine by a buckle-type collar or a body harness made of nylon or leather, not less than one inch in width.
  - (3) The tether has the following properties: it is at least five times the length of the canine's body, as measured from the tip of the nose to the base of the tail; it terminates at both ends with a swivel; it does not weigh more than 1/8 of the canine's weight; and it is free of tangles.
  - (4) The canine is tethered in such a manner as to prevent injury, strangulation, or entanglement.
  - (5) The canine is not outside during a period of extreme weather, including without limitation extreme heat or subfreezing temperatures, thunderstorms, hail storms, tornadoes, tropical storms, or other extreme weather events.
  - (6) The canine has access to water, shelter, and dry ground.
  - (7) The canine is at least six months of age. Puppies shall not be tethered.
  - (8) The canine is not sick or injured.
  - (9) Pulley, running line, or trolley systems are at least 15 feet in length and are less than seven feet above the ground.
  - (10) If there are multiple canines, each canine is tethered separately.
    - (a) This section shall not apply to the transportation of canines.
  - (11) For a first-time violation, the Code Enforcement Officer shall issue a warning notice to the responsible party and shall wait at least 10 days before taking any further enforcement action against the responsible party. Thereafter, each violation of this section shall be subject to enforcement in accordance with § 118-27.2 of this chapter or Article VIII, § 118-42, of the Animal Ordinance. For all civil penalties for violations of this section collected pursuant to Chapter 118, Article V, § 118-27.2, 50% of the amount collected shall be paid to City of Las Vegas, New Mexico, Animal Shelter.

[1] *Editor's Note: Section 6 of this ordinance provided it becomes effective one year after adoption, i.e., 2-15-2013.*

## § 118-27.2. Schedule of penalties for unlawful tethering.

[Added 2-15-2012 by Ord. No. 12-02<sup>[1]</sup>]

- A. First offense, unlawful tethering of canine: warning with ten-day correction period.
- B. Second offense, unlawful tethering of canine: \$100 and additional ten-day correction period.
- C. Third offense, unlawful tethering of canine: \$250.
- D. Fourth and each subsequent offense, Unlawful tethering of a canine: \$500 and one count of animal cruelty (fine of \$500 and/or imprisonment for up to 60 days).

[1] *Editor's Note: Section 6 of this ordinance provided it becomes effective one year after adoption, i.e., 2-15-2013.*

## § 118-28. Abandonment.

[Amended 6-16-1994 by Ord. No. 82-3]

It is unlawful for any person having charge, custody, or ownership to abandon any animal. All animals which are to be abandoned may be turned over to the Animal Control Center or an animal shelter for adoption; such owner shall be required to sign an owner's release relinquishing ownership of said animal. In the event, however, that each animal is not adopted within three working days, the animal may be destroyed pursuant to § 118-5.

## § 118-29. Poisoning.

It is unlawful for any person by any means to make accessible to any animal, with the intent to cause harm or death, any substance which has in any manner been treated or prepared with any harmful or poisonous substance. It is not the intent of this section to prohibit the use of poisonous substances for the control of vermin of significance to the public health.

## § 118-30. Protective care by City.

Whenever the City finds that any animal is or will be without proper care because of injury, illness, incarceration or absence of the owner or person responsible for the care of such animal, the City may take up such animal for protective care; and in the event of sickness or injury upon the advice of a licensed veterinarian, the City may take such action as called for to prevent undue pain and suffering, including immediate destruction of the animal.

## § 118-31. Injury by motorists.

- A. Every operator of a motor or other self-propelled vehicle upon the streets and ways shall immediately, upon injuring, striking, maiming or running down any animal, give such aide as is reasonably able to be rendered. In the absence of the owner, he shall immediately notify the City, furnishing sufficient facts relative to such injury.
- B. Every such operator shall remain at or near the scene until such time as the appropriate authorities arrive, and upon the arrival of said person, such operator shall immediately identify himself to the appropriate authorities. Alternatively, in the absence of the owner, a person may give aide by taking the animal to a veterinary hospital or the Animal Control Center and notifying the City. Such animal shall be deemed an abandoned animal within the meaning of § 118-28 above. This provision does not apply to operators of emergency vehicles.

## § 118-32. Hobbling livestock.

It is unlawful to hobble livestock or other animals by any means which may cause injury or damage to any animal.

## **§ 118-33. Keeping of diseased or painfully crippled animals.**

It is unlawful to have, keep or harbor any animal which is infected with any dangerous or incurable or painfully crippling condition except as hereinafter provided. The City may impound such diseased or painfully crippled animal in accordance with the provisions of this chapter. All such animals impounded following examination and approval by a veterinarian may be destroyed humanely as soon thereafter as is conveniently possible. In the case of destruction of such animal, the City shall not be required to give any of the aforesaid notices provided in this chapter. This section shall not be construed to include veterinary hospitals or animals under active veterinary care.

## **§ 118-34. Animal fights.**

[Amended 6-16-1994 by Ord. No. 82-3]

It is unlawful for any person to promote, stage, hold, manage, conduct, carry on or attend any game, exhibition, contest or fight in which one or more animals is engaged in for the purpose of injuring, killing, maiming or destroying themselves or any other animal. No person shall provoke or entice an animal from the property of its owner for the purpose of engaging the animal in an animal fight.

## **§ 118-35. Confining or crating of fowl.**

It is unlawful to confine any wild or domestic fowl or bird unless provisions are made for the proper feeding and the furnishing of water to such fowl or bird at intervals not longer than 12 hours. It is unlawful to impound any wild or domestic fowl or bird in a crate, box or other enclosure, which does not permit the fowl or bird impounded therein to stand in a naturally erect position.

## **§ 118-36. Birds.**

It is unlawful to willfully kill any bird, or to molest or rob the nest of a bird.

## **Article VI. Sale of Animals**

### **§ 118-37. Use of public property.**

It is unlawful to display, sell or offer for sale, barter, give away or otherwise dispose of any animal upon any street, sidewalk or public park.

### **§ 118-38. Rabbits or fowl.**

It is unlawful to sell, offer for sale, barter or give away any unweaned baby rabbits, or fowl under four weeks of age. Raising of such rabbits and fowl by an individual for his personal use and consumption is not prohibited, provided that he shall maintain proper brooders and other facilities for the care and containment of such animals while they are in his possession. The sale of young fowl by commercial breeders is not prohibited.

### **§ 118-39. Turtles.**

No person shall offer for sale, sell, barter or give away turtles, except in conformance with appropriate federal regulations.

## **Article VII. Exotic Animals; Guard Dogs**

## § 118-40. Wild or exotic animals.

It is unlawful to be in charge of, possess or own:

- A. Any exotic animal or species prohibited by federal or state law.
- B. Any exotic animal or species when kept in such numbers or in such a way as to constitute likelihood of harm to the animals themselves, to human beings or to the property of human beings, or which constitutes a public or private nuisance.
- C. Bats.
- D. Skunks.

## § 118-41. Housing of guard dogs.

- A. It is conducive to the promotion of the health and general welfare of the inhabitants of this City to establish regulations for the proper and safe use of guard dogs used for protecting commercial property.
- B. Whenever there is a guard dog on the premises, the standards of this section, in addition to the other requirements of law and regulations, shall be complied with as follows:
  - (1) Housing shall have antiescape building sufficient to house guard dogs.
  - (2) All gates and entrances to the area where the guard dog is housed, used or trained shall be locked when not in use.
  - (3) Additional measures found necessary by the City shall be taken to protect the public from accidental contact with any guard dogs.
  - (4) Where guard dogs are used outside buildings, the area must be enclosed by at least a six-foot chain link fence or other fence of equal security, wall or adequate wood fence, to which antiescape devices have been added. The adequacy of the fencing shall be subject to the approval of the City.
  - (5) In order to control noise, the City may require a sight barrier which breaks the dogs line-of-sight.
  - (6) In buildings where guard dogs are housed, exterior glass must be adequate, or additional protective measures taken by the owner as required by the City, to prevent the dog from jumping through it.
  - (7) The building and yard in which a guard dog is housed must be posted with bilingual (English and Spanish) or visual guard dog signs, shall not be more than 200 feet apart, and shall be at all property corners and at every entrance into the area.
  - (8) For guard dogs either transported or utilized in vehicles, measures prescribed by rule and regulation of the City must be taken to protect the public from accidental contact with a guard dog.
  - (9) A handler is required to be physically present while guard dogs are being utilized at temporary sites which do not comply with this section of this chapter.
- C. Exclusions. Dogs which are used as private guard dogs on the property of their owner's private residence shall be excluded from the provisions of this section unless the residence is located on premises utilized for commercial purposes. Guard dogs kept in a kennel with a valid professional animal permit are also excluded.

## Article VIII. Penalties

### § 118-42. Penalty.

Any person found guilty of violating the provisions of this chapter may be sentenced or fined, or both, up to the maximum amount permitted by state law for violation of municipal ordinances, such amount to be set by the Magistrate Judge in his/her sound discretion, but not to exceed the amount established under NMSA 1978 Compilation, § 3-17-1C. Each day this chapter is violated shall constitute a separate offense.

### **§ 118-43. Repeal.**

Sections 8-1-1 through 8-3-12 of the 1972 Municipal Code of the City of Las Vegas, New Mexico, relating to Animals and Fowl, as well as any other ordinances of said municipality which are inconsistent with the provisions hereof, are hereby repealed.

**Addendum C**  
**Recommended Minimum Standards for**  
**Animal Shelters in New Mexico**

**RECOMMENDED MINIMUM STANDARDS FOR**  
**ANIMAL SHELTERS IN NEW MEXICO**  
**Submitted to the Animal Sheltering Board**  
**February, 2012 and Revised June, 2012**

**Introduction**

The Animal Sheltering Board (ASB) was created in 2007 by the New Mexico State legislature under the **Animal Sheltering Services Act [Chapter 77, Article 1B NMSA 1978]** (The Act). ASB was chartered to provide recommended standards for humane housing and treatment of New Mexico's shelter animals and to create rules guiding the humane euthanasia of animals in the State's animal shelters.

The standards presented below are a compilation of guidelines developed in November 2007 by New Mexico animal welfare experts (listed in the Appendix) brought together by Animal Protection of New Mexico, "Guidelines for Standards of Care in Animal Shelters" (GSCAS) published in 2010 by The Association of Shelter Veterinarians (ASV) and "Facility Housing and Design" published in 2010 by the University of California, Davis, Koret Shelter Medicine Program (Koret). It should be noted that these Guidelines were developed from multiple scientific studies conducted by ASV in shelters throughout the country.

**Overview**

The overriding principles guiding these recommended standards also include the American Veterinary Medical Association's (AVMA) Animal Welfare Principles stating "Animals should be treated with respect and dignity throughout their lives" (AVMA 2006) and the GSCAS use of the Five Freedoms For Animal Welfare (Farm Animal Welfare Council 2009) shown below:

1. Freedom from Hunger and Thirst	by ready access to fresh water and a diet to maintain full health and vigor
2. Freedom from Discomfort	by providing an appropriate environment including shelter and a comfortable resting area
3. Freedom from Pain	by prevention or rapid diagnosis and treatment
4. Freedom to Express Normal Behavior	by providing sufficient space, proper facilities and company of an animal's own kind
5. Freedom from Fear and Distress	by enduring conditions and treatment which avoid mental suffering

As shelters work towards incorporating these standards, a key element for success is the development and use of written protocols to achieve and maintain these standards. All staff and volunteers must have access to and be trained on these protocols. Further, it is the recommendation of the ASV that a veterinarian be involved in the development of these protocols and in the supervision of medical and surgical care of the animals.

As shelter management and community's consider these recommendations, it is important to point out that according to the Koret shelter design standards, "The type of housing encountered in a shelter is arguably the single most important factor in determining the quality of an animal's experience in that environment. Housing impacts the animal 24 hours a day and affects everything from stress level and disease risk to food intake and sleep quality."

While it is understood that New Mexico has a pet overpopulation problem, shelter management must take on the challenge of making best efforts to provide effective adoption and foster programs in order to move animals through the shelter as quickly as possible. The ASV Guidelines and Koret studies have demonstrated in shelters across the country, that overcrowding in shelters leads to increased stress which leads to an increase in illness. Calculating capacity

takes into account staffing as well as cage space. The National Association of Animal Control Officers (NACA) and the Humane Society of the United States (HSUS) recommend a minimum of 15 minutes of care time per day for feeding and cleaning each animal housed in the shelter (9 minutes for cleaning and 6 minutes for feeding (ASV). To calculate optimal shelter capacity, see “calculating shelter capacity” at [www.sheltermedicine.com](http://www.sheltermedicine.com).

The goal of these recommended standards is to provide shelter animals covered by The Act humane treatment, safe and adequate facilities, and proper care to ensure their health and well-being while in the shelter’s care.

## **1. STRUCTURAL STANDARDS**

All exterior structures and fencing should:

- A. be constructed of building materials that will ensure the establishment of a sound physical structure.
- B. be maintained in good repair.
- C. protect animals kept therein from injury and ensure containment of animals within the shelter.
- D. exclude the entry of outside animals and unauthorized persons.
- E. include four solid walls on all buildings to protect animals from weather conditions and prevent entry of unauthorized persons.
- F. include fencing constructed sufficiently to prevent dogs from jumping or climbing or digging to escape.

## **2. FACILITY STANDARDS**

- A. Animal housing areas should be physically separated from places where food and drink for human consumption are prepared, served or stored.
- B. Interior building surfaces should be constructed and maintained so that they are impervious to moisture and may be readily cleaned.
- C. Animal food storage and equipment cleaning areas should be physically separated from animal housing.
- D. Reliable and adequate electric power and/or gas should be provided for lighting, air circulation, heating and cooling.
- E. Reliable and adequate potable (drinkable, clean, fresh) water should be provided. Back flow preventers should be installed on any threaded faucets where hoses may be attached for the purpose of cleaning the facility or on the main water line serving the facility.
- F. Noise control should be considered for the well-being of the animals as well as visitors, volunteers and staff. Excessive noise contributes to adverse behavioral and physiological responses. (ASV) Dogs and cats are more sensitive to noise than humans, with cats being more sensitive than dogs. Cats are adversely



affected by the sound of barking dogs. Noise mitigation should include a) housing cats away from the sound of dogs, b) facility modifications to minimize or contain barking, c) training staff to minimize slamming cage doors and d) using music to reduce animal stress. It is worth noting that in one study, "heavy metal music" was shown to increase barking while classical music reduced it (Wells 2000).

- G. Readily accessible washrooms or sinks should be provided to maintain personal hygiene among animal caretakers. A two-compartment sink in good repair should be provided for washing and sanitizing equipment used for animal care and feeding. A tub should be available to wash any animal that becomes soiled, in order to avoid the use of hoses for cleaning animals.
- H. Indoor housing for animals should be sufficiently heated or cooled to protect animals from extreme temperatures, and to provide for their health and comfort at all times. The ambient temperature should be consistent with the requirements of the specific species: i.e., 70 - 72 degrees Fahrenheit for dogs/cats/other domestic animals. Birds and reptiles require individual lighting and heating to be housed correctly.
- I. Indoor housing for animals should be adequately ventilated with fresh air to minimize odors and moisture and to provide for the health and comfort of the animals at all times. Kennels should have fresh air ventilation providing ten or more air changes per hour in animal housing areas or may recycle air through a filter system.
- J. Water supply should allow for hose hook-up, to readily reach all parts of animal housing. Water pressure should be adequate for cleaning of animal housing areas.
- K. A suitable method should be provided to rapidly eliminate excess water from animal housing facilities. If drains are used, they should be properly constructed and kept in good repair. If closed drainage systems are used, wastewater should be disposed of by connection to a sanitary sewer or any approved sewage disposal system.

### **3. ANIMAL ENCLOSURE STANDARDS**

- A. Primary enclosures defined: Primary enclosures are those animal enclosures (within the exterior building) in which the animal normally eats, eliminates, rests, and sleeps.
- B. Primary enclosures must provide sufficient space to allow each animal, regardless of species, to make normal postural adjustments, e.g., to turn freely and to easily stand, sit, stretch, move their head, without touching the touch of the enclosure, lie in a comfortable position with limbs extended, move about and assume a comfortable posture for feeding, drinking, urinating and defecating. In addition, cats and dogs should be able to hold their tails erect when in a normal standing position. (ASV)
- C. Primary enclosures should allow animals to be able to see out, but also provide the opportunity to avoid visual contact. (ASV)

- D. All animals housed at the shelter should be confined to a primary enclosure at all times unless under the direct supervision of shelter personnel or a qualified, appointed volunteer.
- E. Primary enclosures should be structurally sound and maintained in good repair and sanitary condition to protect the animals from injury and disease. They should be constructed and maintained to enable the animals to remain dry and clean and to provide convenient access to food and clean water. Latches must be secure and in good working order so that animals cannot escape.
- F. The floors of the primary enclosures should be constructed to prevent injury to the animals, and to ensure adequate drainage and prevent pooling of fluids within the primary enclosures for dogs. Wire-mesh bottoms or slatted floors in cages are not acceptable.
- G. For enclosures that allow animals access to both inside and outside areas, guillotine or other doors that separate the two enclosure sections should be in proper working order.
- H. Floors in dog runs should slope to drain liquid out of runs and prevent pooling or puddles in the runs or walkways. The slope should be  $\frac{1}{4}$  to  $\frac{1}{2}$  inch per linear foot.
- I. There should be solid walls between dog runs to prevent water and waste material from flowing from run to run. The solid walls should be of a height sufficient to prevent nose-to-nose contact of animals between the runs. In addition, fencing or other materials that allow for airflow should be used above the solid walls (vertically and horizontally) to provide a protective barrier at least six feet high between runs, to prevent dogs from jumping over, except in the case of "real-life" rooms which are dog rooms each with its own self-contained heating/cooling/air exchange and drainage systems.
- J. All solid surfaces of the dog runs should be constructed of a material (such as concrete, stone, cement block, brick, or metal) that is water resistant and can be cleaned and sanitized. Concrete floors, sealed, not painted, are preferable because they can be cleaned and disinfected most effectively. All fencing materials should be water-resistant and of materials that can be easily cleaned and sanitized. Consideration must be given to gauge and spacing of any fencing materials used. Chicken wire, barbed wire and wood should never be used.
- K. Primary enclosures (individual cages) for cats should be made of stainless steel, fiberglass, or other impervious material that is water-resistant and can be cleaned and sanitized. (Chicken wire, barbed wire, and wood should never be used.) The cages should have a solid floor, sides, and top. The front should be designed to maximize light and airflow.
- L. Space Requirements for Cats - Cats must be able to assume normal postures. Cats housed in cages with 11 square feet of floor space were found to be significantly less stressed (and therefore more healthy) than those housed with only 5.3 square feet of space (the typical dimensions of most commercially available cat housing). (ASV)

- M. Primary enclosures should provide at least 28" by 30" (5.8 sq. ft.) of clear floor space (excluding space occupied by bed, food and water dishes and litter boxes). Ideally a hiding box is incorporated which means the compartment should be about 3 feet wide. The height should be at least 30" to allow the cat to stand on its hind legs and fully extend its front legs without touching the top on the cage. (Koret)
- 1) The size of the primary enclosure for single cats should provide 2 feet of triangulated distance between the litter box, resting area and feeding area. (ASV)
  - 2) When there is more than one cat in a cage, such as a nursing mother with kittens, additional floor and vertical space should be provided.
- N. Feral cat boxes or other box-like structures, which allow for hiding places within the cage, should definitely be considered to reduce stress for all cats.
- O. Litter boxes should be provided for cats in their primary enclosure, with soiled litter disposed on as needed basis, at a minimum once a day. Litter boxes may be disposable, or reusable if they are cleaned daily and sanitized before used by another cat.
- P. If cats are to be moved from one location to another, it is highly recommended that the carrier be covered with a towel or sheet to reduce stress and thus susceptibility to illness.
- Q. If colony rooms are used to house cats, follow the guidelines listed below:
- 1) There should be at least 18 square feet of floor space per cat and the opportunity to maintain a distance of 3 to 10 feet distance between themselves and other cats. This does not include perches or walkways, but can include outdoor access in temperate climates assuming cats have 24-hour access to indoors. (Koret)
  - 2) Cats whose vaccination history is unknown should be evaluated for health and behavior, vaccinated, and isolated for at least 24 hours for observation before being placed in cat colony rooms.
  - 3) Separate unsterilized males from females.
  - 4) Young kittens should never be housed with adult cats in colony rooms.
  - 5) Nursing mothers and their kittens should never be housed in colony rooms.
  - 6) Include one 12-inch by 18-inch cat litter pan for every three cats or five kittens. Ideally, the litter pan should be stainless steel so it can be sterilized. Plastic litters boxes cannot be sufficiently disinfected and therefore can be the source of disease transmission.
  - 7) Have water and dry food available at all times.
  - 8) Equip colony rooms with shelves or resting boxes; provide cages with open doors for animals that prefer to be isolated.

- 9) Use materials that are stainless steel, fiberglass or other materials that are water resistant and can be cleaned and sanitized. Wood should not be used.
  - 10) Provide clean bedding materials on a daily basis.
- M. Care should be taken to ensure that animals are not able to escape from their primary enclosure. Special attention must be given when housing animals that are aggressive, under quarantine, or under protective custody. Condition of all enclosures should be monitored daily and various types of locks (from nose-proof or paw-proof to those requiring keys) should be considered.
- N. Primary enclosures should house preferably one (1) animal (for optimum disease control) but certainly no more than two (2) compatible, non-breeding animals per enclosure, except when litters are housed with their dams or colony housing (as designed above) is used.
- O. Space Requirements for Dogs – In considering these guidelines, it is important that the animal be able to assume normal postures and engage in normal behaviors such as playing and moving freely about without encountering another dog. The space should be large enough to accommodate bedding and food and water bowls:

1) Floor space:

- a) A dog that is very small, such as a toy breed or puppy, should have a minimum of four square feet of flat floor space.
  - b) A dog that weighs between 15 and 30 pounds should have a minimum of eight square feet of flat floor space.
  - c) A dog that weighs between 30 and 65 pounds should have a minimum of 12 square feet of flat floor space.
  - d) A dog that weighs more than 65 pounds should have a minimum of 20 square feet of flat floor space.
- 2) Vertical space: Enclosure height should be a minimum of 1 ½ times the height of the dog at the shoulder.
- 3) If more than one dog occupies the same primary enclosure, space should be figured for the first dog, with each additional dog needing an additional one-half of the minimum square footage required. Further, if beds are used, there must be one bed for each dog to prevent guarding by dominant dogs such that less dominant dogs are prevented access.
- 4) When the recommended space requirements for dogs are not met due to shelter configuration, the dog should be exercised for a period of not less than 20 minutes, twice daily. For dogs that require an opportunity to exercise, a written plan should be on file and each exercise session noted.

- R. Isolation facilities must be provided for animals with infectious diseases. Generally, about 10% of the total housing should be designated for this purpose. This housing should be of equal quality to other housing in the shelter. To minimize contamination, this housing should be double-sided so that cleaning can take place without removing the animal. Ideally, hand washing stations should be present in all isolation facilities.
- S. Enrichment is a means of improving the environment and behavioral care for animals in confined care. The purpose of enrichment is to reduce stress and improve well-being by providing physical and mental stimulation, encouraging species-typical behaviors (e.g., chewing for dogs and rodents and scratching for cats). Enrichment should be given the same significance as other components of animal care, such as nutrition and veterinary care, and should not be considered optional (ASV).
- T. Outdoor Primary Enclosures:

It is *not* recommended that primary enclosures be exclusively outdoors and especially not for very young, old, sick or injured animals. (Primary enclosures are those animal enclosures in which the animal normally eats, eliminates, rests, and sleeps.) However, when this is necessary:

- 1) A structurally sound, *weatherproof* enclosure with adequate shade and ventilation should be made accessible to any animal housed exclusively outdoors. Shelter must be provided so that animals stay warm and dry during cold weather and stay shaded and cool during hot weather. Such shelter shall be a water resistant and windproof structure of suitable size to accommodate the animal(s) and allow retention of body heat during cold weather. Such shelter should also have a water resistant door covering or offset doorway to minimize drafts, provide proper ventilation, and be made of a durable material with a solid floor raised off the ground to prevent water entry.
- 2) A structure that provides adequate shelter might not provide adequate shade. For example, a doghouse within a fenced area may protect the dog from the wind and rain, but may be too hot inside when exposed to direct sunlight during the warmer months. Shade should then be provided and the animal must be able to rest in the shade, outside of the interior structure but still within the fencing or run.
- 3) A shaded area should be provided to all animals housed in an outdoor primary enclosure for protection from the direct rays of the sun. The shaded area should be proportional to the size of the animal and should be positioned so that maximum shade protection is provided.
- 4) Sufficient clean, absorbent bedding material in addition to other means of protection from weather should be provided for the health and safety of the animal and shall prevent strong odors from forming.

- 1) Floors of outdoor enclosures may be constructed of gravel, sand, soil, or preferably of a solid material such as concrete, *since it is not possible to sanitize or disinfect gravel, sand, or soil.*
- T. Tethering dogs is not an acceptable alternative to an enclosure. Temporary, short-term tethering of dogs may be employed while cleaning the primary enclosure or in the event of an emergency, such as a fire or flood, until transport to another facility can be arranged. Care should be taken to ensure the safety of the dog while it is tethered. (Cats should never be tethered.)
  - U. Animals placed in crates or carriers even for a short time must have ample space to stand up, turn around and lie down. Crates and carriers must be disinfected and dried after each use and before another animal is placed in the crate or carrier.

#### 4. SANITATION STANDARDS

- A. Written sanitation protocols should be developed to provide consistent and thorough sanitation of the facilities. Ideally, sanitation protocols should be developed and reviewed periodically in consultation with a veterinarian familiar with shelter medicine practices. Protocols should be updated to take into account current knowledge in the field.
- B. To prevent contamination of animals and to reduce disease hazards and odors, animal waste should be removed from primary enclosures daily *or more often as necessary.*
- C. Cages, kennels, containers, equipment, and other items should be cleaned daily to maintain sanitary conditions. One of the most effective methods is to wash all surfaces with a dilution of 1 part bleach to 30 parts water, rinse after ten minutes and allow the surface to dry. Care should be taken to ensure that this exact ratio is followed not only because it has been proven to be most effective, but also to protect animals from chemical injuries. Since bleach can cause respiratory problems for cats and it can also corrode stainless steel, quaternary disinfectants should be used instead in those cases. *Animals must be removed from the enclosures during the cleaning process* and precautions taken to avoid cross contamination.
- D. To minimize the spread of disease, cleaning should be carried out in the following order, from first to last:
  - a. Healthy puppies and kittens and healthy and nursing bitches and queens
  - b. Healthy adult animals
  - c. Unhealthy animals
- E. To minimize the spread of disease, water and food containers and all other utensils should be cleaned and sanitized using generally accepted methods such as the use of heat and chemical sanitizing solution. These containers should be cleaned and sanitized as often as necessary to maintain sanitary conditions, however food pans must be cleaned between each use. If sinks are the only means for cleaning, water and food bowls must be soaked and washed separately

from litter pans with water and disinfectant changed between water/food bowls and litter pans.

- F. When cleaning, sanitizing, and disinfecting, product manufacturer instructions should always be followed precisely. Never mix bleach with quaternary ammonia compounds, as mixtures hazardous to both animals and people will result. Certain mixtures may render the products ineffective, as well. Pine products and fumes are extremely toxic to cats and should never be used around them or to clean cat enclosures, bowls, etc. (See [www.sheltermedicine.com](http://www.sheltermedicine.com) or [www.animalsheltering.org](http://www.animalsheltering.org) for more detail.)
- G. Mopping should be avoided if possible to reduce the spread of pathogen transmission. When mopping cannot be avoided (if hosing is not possible), then the disinfectant solution should not be used from one housing area to another (ASV).
- H. Water and food bowls should be made of metal. Plastic is not recommended because it may be chewed and ingested and may retain harmful contaminants.
- I. Animal and food waste, soiled bedding, debris, and other organic waste should be stored in closed containers and disposed of so that vermin infestation, odors, disease hazards, and nuisances are minimized. Such waste should be removed at least weekly from the facility. Any reusable trash containers should be regularly sanitized and disinfected.
- J. Pens and runs using absorbent or loose flooring such as sand, gravel, or soil should have such materials replaced as often as necessary to attempt to maintain sanitary conditions. Because it is not possible to sanitize or disinfect these organic materials, it is all the more important to remove and replace areas that become soiled with urine and/or fecal matter, when the surface is muddy, when puddles of water are present, or when odors and vermin (such as ants and flies) are present.
- K. Building and grounds should be kept clean, in good repair, and free from trash.
- L. Weeds should be mowed or cut down in areas where animals are kept or exercised.
- M. An effective program for the control of insects, ectoparasites, and avian and mammalian pests should be maintained.
- N. Unopened supplies of food should be stored off the floor and be adequately protected against infestation or contamination by vermin. Opened supplies of food should be stored separately in closed waterproof containers.
- O. Animal bedding should also be stored off the floor and be adequately protected against infestation or contamination.
- P. Dead animals at the facility should be stored and disposed of in strict compliance with applicable state laws/local ordinances and in a way that will not cause a disease hazard or nuisance. (See **Animal Sheltering Rules NMSA Title 16.24.3.8m.**)

- Q. A suitable method should be provided to rapidly eliminate excess water from animal housing facilities. If drains are used, they should be properly constructed and kept in good repair. If closed drainage systems are used, wastewater should be disposed of by connection to a sanitary sewer or any approved sewage disposal system.

## 5. CARE AND HANDLING STANDARDS

### A. FOOD AND WATER

- 1) Animals should be fed twice daily (except when advised otherwise during veterinary treatment or in cases of malnutrition when smaller portions throughout the day are needed) to avoid medical problems associated with overeating. The food must be free from contamination, palatable, and of sufficient quality and nutritive value to meet the normal daily requirements for the condition, size, and age of the animal. Refrigeration should be provided for perishable food.
- 2) Uneaten food must be discarded after 24 hours. Food that has been offered to an animal and remains uneaten must not be fed to other animals (ASV).
- 3) Care should be taken not to underfeed or overfeed animals.
- 4) Special consideration regarding types of food and frequency should be given to puppies, kittens, older animals, and nursing dams.
- 5) Malnourished or emaciated animals may need an increased food intake, but introduction of food must be regulated and increased gradually, preferably with veterinary guidance.
- 6) Animals must be provided potable (drinkable, clean, fresh) water at all times (except when water must be withheld under special veterinary care).
- 7) Food and water containers should be accessible to the animal and located to minimize contamination by excreta or other material. These containers should be cleaned daily. Disposable food containers may be used *only if discarded after each use.*
- 8) Food and water containers should be of a size appropriate to ensure accessibility based on the size of the animal
- 9) Spoiled, moldy food or food contaminated with feces, droppings, or insects should never be used. Food left in food bowls from the previous day should be disposed of, disposable bowls discarded, and non-disposable bowls cleaned.

### B. CLASSIFICATION AND SEPARATION

- 1) Animals housed in the same primary enclosure (where they eat, eliminate, rest, and sleep) should be maintained in compatible groups, with the following additional restrictions:



- a) Primary enclosures should house preferably one (1) animal but certainly no more than two (2) compatible, non-breeding animals per enclosure, except when litters are housed with their dams.
  - b) A female in season (estrus) should not be housed in the same primary enclosure with a male.
  - c) An unaltered male should not be housed in the same primary enclosure with an unaltered female.
  - d) Any dog or cat exhibiting an aggressive disposition should be housed individually in its primary enclosure and the enclosure appropriately marked for protection of shelter personnel.
  - e) Animals under four months of age should not be housed in the same primary enclosure with adult animals other than their dams. *Attempts should always be made to keep nursing mothers and their babies as removed from other animals as possible, to allow them privacy, to protect them from unwanted intrusion and noise, to alleviate fear/aggression, and to promote their general well being.*
  - f) Dogs should not be housed in the same primary enclosure with cats, nor should dogs or cats be housed in the same primary enclosure with any other species of animals.
- 2) Animals that have bitten a human must be quarantined pursuant to applicable New Mexico state law (see NMSA 1978 § 77-1-6 and 77-1-10) and local municipal or county ordinance. A veterinarian should be consulted. Animals under quarantine for observation of rabies symptoms after a bite incident should be physically separated from all other animals. Because most turn out to be healthy animals, often with owners, these animals should never be housed with animals under treatment for a communicable disease. Such quarantine area should have a separate ventilation system and should only be accessible to shelter personnel or owners accompanied by shelter personnel.
  - 3) Animals diagnosed and/or under treatment for a communicable disease should be physically separated from healthy animals to minimize dissemination of disease. Such area should have a separate ventilation system.
  - 4) Cats should be housed in a separate building if at all possible, or at the very least in a separate room that is as far-removed as possible from any room containing dog runs.

## 6. OTHER CARE CONSIDERATIONS

- A. Sheltered animals must always be handled safely and humanely to prevent injury, distress, and spread of disease to both to the animal and personnel. Adequate

animal handling equipment such as transfer cages, nets, catch poles, syringe poles, etc. must be available and kept clean and in good repair to ensure the safety of staff and animals. Staff should be trained in current humane and sanitary animal handling techniques. (Please see Shelter Resource List, pages 20-21.)

- B. The minimal amount of physical restraint needed to accomplish the task without injury to people or animals should be used for the minimal duration necessary (ASV).
- C. The use of catch poles for routine restraint of cats, including carrying or lifting, is inhumane and poses significant risk of injury to the animal; therefore they must not be used for such purposes. Humane traps, purpose-designed boxes or nets should be used for handling fractious cats or cats who appear unused to handling (ASV).
- D. Cats should be provided with clean bedding in each cage. Bedding should be replaced when soiled or wet, and also for each new animal introduced to the enclosure.
- E. Bedding or platforms should be provided to dogs on an as-needed basis. Particularly, clean bedding should be provided to old, young, ill, or injured dogs. Bedding should be replaced when soiled or wet, and also for each new animal introduced to the enclosure. Only single layer bedding should be used for puppies and kittens, to prevent accidental suffocation.
- F. Nursing dams should be provided with a whelping box if possible. If a shelter is unable to provide one, it should be noted that as long as nursing dams have adequate bedding, warmth, and cleanliness, they seem to do fine. If the cost of a whelping box is prohibitive, it is fairly simple to fashion one out of the bottom of a very large travel kennel, use a plastic kiddie pool or one can be built. Bedding should be provided in the whelping box and replaced when soiled or wet. The whelping box should be large enough for the dam to stretch out and nurse her offspring. *Attempts should always be made to keep nursing mothers and their babies as removed from other animals as possible, to allow them privacy, to protect them from unwanted intrusion and noise, to alleviate fear/aggression, and to promote their general well being.*
- G. Animals should be cleaned and groomed on an as-needed basis, while keeping in mind that medical issues need to be treated, especially when an animal has a matted coat that can cause pain, skin or eye irritation, or trap fecal matter. Bathing may be necessary to prevent or treat parasites/insects. Basic grooming also ensures that claws are not so long as to hinder movement or cause pain to the animal. An animal that needs help in this regard should not be made to wait until the shelter determines the dog to be its "property," as no animal should be allowed to suffer while in the care of the shelter.

- H. Care must be taken to ensure that animals are not squirted or hosed with water, not put in contact with chemicals, and not placed back in a wet or damp enclosure.

**7. DISEASE CONTROL/ HEALTH/ VETERINARY CARE STANDARDS**

- A. No animal should ever be allowed to suffer due to lack of veterinary care.
- B. Failure to provide treatment for pain is unacceptable (ASV).
- C. Animals should be examined at the time of impound for injury and signs of disease - under the guidance of a veterinarian, if possible - and treated immediately if in pain or distress. Training is needed in this regard, and if shelter personnel are unsure or in doubt, they must be encouraged to immediately call someone qualified to assist. If sick/injured animals cannot be provided veterinary care in a manner timely enough to stop their pain and suffering, they must be humanely euthanized at once.
- D. Some common signs of illness, injury or parasitic infestation in dogs and cats that may warrant veterinary care include:
  - 1) Eyes are watery, appear swollen, or show discharge
  - 2) Ears are red or inflamed, show discharge, or have a foul odor
  - 3) Nose shows discharge (mucous, blood, or pus), or is crusty, congested, or blocked
  - 4) Gums are swollen or inflamed, teeth are loose or brown, or mouth has a foul odor.
  - 5) Animal is sneezing, coughing, or wheezing
  - 6) Animal has fleas or ticks, skin shows swelling or lesions
  - 7) Animal limps, or does not place weight on a limb
  - 8) Animal is thin or obese
  - 9) Animal has wounds, abscesses, cuts, or abrasions
  - 10) Body temperature that is abnormal
  - 11) Animal has vomiting or diarrhea
- D. Have a trained and experienced staff member, a veterinary technician, or a veterinarian available to check animals and to provide care. Instruct every staff member to note and record all symptoms of possible illness and to bring them to a supervisor's attention at once.
- E. Animals should be observed daily for signs of disease or distress. An animal suspected of having an infectious disease should be physically separated from other susceptible animals until the condition is determined to be non-infectious.
- F. When animals are brought to the shelter after normal working hours, a system should be in place to care for injured and sick animals during that time. Shelters should enter into a contract with a local veterinarian who can be available on call, and there must, at a minimum, be a licensed euthanasia technician (see Section 13 for more information) on call 24 hours per day for emergency situations.
- G. Animals with obvious signs of serious disease, injury, or distress that cannot be addressed, as well as aggressive animals, should be humanely destroyed. It may

be necessary to euthanize an animal for humane reasons even if the holding time requirements have not been met, as it is unacceptable to allow an animal to suffer while in the shelter's care.

- H. Dogs and cats should be dipped or sprayed for fleas and ticks as necessary, according to the season and region of the state, and according to manufacturer instructions concerning different treatment strengths depending on size, age, or health of animal.

## 8. VACCINATIONS

- A. It is strongly recommended that all dogs and cats be vaccinated upon initial impound at animal shelters. A veterinarian or trained staff member should administer the following core vaccines:

- 1) Dogs:

- a) DA2PP or DHPP vaccine: to provide protection against distemper, adenovirus-2, parvovirus, parainfluenza. Adult dogs should be vaccinated once upon intake. Puppies should be vaccinated starting at 4-6 weeks of age and revaccinated every 2-4 weeks until 16-18 weeks of age.
- b) Bordatella bronchiseptica vaccine: to protect against "kennel cough" for puppies and adult dogs.

- 2) Cats:

FVRCP vaccine: to provide protection against feline herpesvirus, feline viral rhinotracheitis, feline calicivirus, and feline panleukopenia. Adult cats should be vaccinated once upon intake. Kittens should be vaccinated starting at 4-6 weeks of age and revaccinated every 2-4 weeks until 18 weeks of age.

- B. All animals should be considered unvaccinated unless a documented medical record exists. Special consideration should be given to animals with medical conditions, pregnant animals, and animals less than 4 weeks old. (For more information, consult with your staff or consulting veterinarian or the Association of Shelter Veterinarians website.)
- C. Recognizing financial constraints common to many shelters, the "core" vaccines noted above should be administered *at the very least* at the time of adoption, *but for purposes of optimum disease control, vaccination upon impound is necessary.*
- D. Rabies vaccinations may be given at the time of adoption or by the adopter's veterinarian, depending on local municipal or county ordinance.
- E. Rabies vaccinations must be administered pursuant to applicable New Mexico state law:

**NMSA 1978 § 77-1-3 Vaccination of dogs and cats required.**

Any person who owns or keeps a dog or cat over the age of three months in this state shall have the dog or cat vaccinated against rabies as prescribed by

regulation of the health and environment department [department of health]. All antirabies vaccine shall be administered by or under the supervision of a licensed veterinarian who shall issue a serially numbered certificate and tag for each such administration.

**See also NEW MEXICO ADMINISTRATIVE CODE, Title 7 (Health), Chapter 4 (Disease Control [Epidemiology]), Part 2 (Animal Control Requirements).**

**9. RECORDKEEPING STANDARDS**

- A. Records should be kept for each animal impounded, for each that is accepted as an owner-surrender, each animal that is brought to the shelter by a member of the public as a stray and for each that is otherwise acquired.
- B. Records should include the date acquired, manner of acquisition (animal control officer, public intake, owner surrender, etc.), description and identifying characteristics including species, breed, color, age, weight, sex, and any background information (including tag and/or microchip information), reason for impoundment or relinquishment, veterinary care, disposition of the animal, date of redemption, adoption, transfer of ownership, or euthanasia, and the name address and telephone number of the receiving person or entity.
- C. Collars, tags, or other potentially identifiable "gear" should be kept on the animal or in the animal's file during the impound time.
- D. Each animal should be identifiable by use of cage/run cards and/or identifying collars.
- E. Ideally, two photographs should be taken of each animal and maintained with its records and posted on its cage, to aid in identifying an animal and to minimize the possibility of a euthanasia mistake.
- F. Shelters should maintain records for a minimum of two years from the date of an animal's final disposition.

**10. COMMUNITY ACCESS AND SERVICE STANDARDS**

- A. Shelters should be accessible to residents seeking to reclaim their animal or adopt an animal. Hours open to the public should be clearly marked on the facility. The facility's telephone and address should be listed in local telephone directories and if possible, the shelter should have a website with all pertinent information as well as listings of lost or found animals and animals available for adoption. It is recommended that shelters be open to the public at least one weekend day, and at least two days until at least 6:00 p.m. (or have both Saturday and Sunday hours).
- B. Municipal Shelters should have provisions for animals dropped off after hours, but care must be taken so that animals are protected from injury, theft, and the elements. Similarly, provisions should be made for after-hours entry, impoundment, and treatment procedures for animal control officers to follow. Sick or injured animals must be attended to by trained personnel at once due to both the potential for unalleviated suffering of the animal as well as liability for the shelter.

- C. When an animal has visible identification upon impound or a microchip, shelter personnel should make every attempt to contact the owner. Each animal must be scanned for the presence of a microchip and the number entered into the animal's record. Further, if a microchip is found, the shelter must, in the case of owner surrenders, determine if the surrendering owner matches the name on the microchip to ascertain if the animal has potentially been stolen. In the case of stray animals, the shelter must promptly attempt to contact the owner to whom the chip is registered first by phone, and in the event no contact can be made via phone, then the shelter must send a letter to the address listed on the microchip registration.
- D. In addition to being scanned at intake, animals must be rescanned prior to final disposition and if that disposition is euthanasia, scanning must be done per the rules pertaining to euthanasia in **Title 16 Chapter 24, Part 3, "Duties of Licensee and Certificate Holders."**
- E. Stray animals without identification preferably should be held for at least 5 days to give an owner sufficient time to reclaim the animal. Stray animals with identification (tag, tattoo, and/or microchip) preferably should be held for 10 days to allow the shelter sufficient time for notification and the owner sufficient time to reclaim the animal. Shelters should refer to their local municipal or county ordinance, which often addresses the *minimum* holding time required.
- F. Animals in protective custody through law enforcement situations must be in locked areas (with appropriate signage) that meet the above standards and are inaccessible to the public. Depending on the type of case, an owner may be allowed to visit the animal/s. It is recommended that shelters take the initiative and discuss in advance with their governing city or county administration and district attorney or prosecutors to determine what financial arrangements (bonding or other) can be made in the event of large numbers of animals and/or lengthy stays to pay for costs incurred by shelter. This is especially important in cases dealing with hoarding or other abuse situations.

**11. SHELTER PERSONNEL STANDARDS**

- A. All shelter employees should be trained in all aspects of their responsibilities. (Please see Shelter Resource List, pages 20-21.)

Training topics should include but are not limited to:

- 1) Animal health and disease control
- 2) Humane care and treatment of animals
- 3) Control of animals in an animal shelter
- 4) Transportation of animals
- 5) Disease recognition
- 6) Animal Breed identification and behavior
- 7) Pre-adoption evaluation, temperament testing
- 8) Adoption policies and procedures
- 9) Handling, capture and restraint techniques
- 10) Personnel safety and use of equipment
- 11) Euthanasia

- B. Shelter personnel should be provided with a comprehensive standard operating procedures (SOP) manual. (Please see Shelter Resource List, pages 20-21.) The SOP manual should outline all shelter policies and procedures, as well as duties for each position.
- C. Shelter personnel shall adhere to New Mexico's anti-cruelty law at all times: **NMSA 1978 § 30-15 -1 et seq.**

**§ 30-18-1. Cruelty to animals; extreme cruelty to animals; penalties; exceptions.**

- A. As used in this section, "animal" does not include insects or reptiles.
- B. Cruelty to animals consists of a person:
  - (1) negligently mistreating, injuring, killing without lawful justification or tormenting an animal; or
  - (2) abandoning or failing to provide necessary sustenance to an animal under that person's custody or control.
- C. As used in Subsection B of this section, "lawful justification" means:
  - (1) humanely destroying a sick or injured animal; or
  - (2) protecting a person or animal from death or injury due to an attack by another animal.
- D. Whoever commits cruelty to animals is guilty of a misdemeanor and shall be sentenced pursuant to the provisions of **Section 31-19-1 NMSA 1978**. Upon a fourth or subsequent conviction for committing cruelty to animals, the offender is guilty of a fourth degree felony and shall be sentenced pursuant to the provisions of **Section 31-18-15 NMSA 1978**.
- E. Extreme cruelty to animals consists of a person:
  - (1) intentionally or maliciously torturing, mutilating, injuring or poisoning an animal; or
  - (2) maliciously killing an animal.
- F. Whoever commits extreme cruelty to animals is guilty of a fourth degree felony and shall be sentenced pursuant to the provisions of **Section 31-18-15 NMSA 1978**.

See also:

- 30-18-1.1 Seizure of animals; notice.**
- 30-18-1.2 Disposition of seized animals.**
- 30-18-1.3 Costs.**
- 30-18-2, 30-18-2.1 Repealed.**
- 30-18-3 Unlawful branding.**
- 30-18-4 Unlawful disposition of animal.**
- 30-18-5 Illegal confinement of animals.**
- 30-18-6 Transporting stolen livestock.**
- 30-18-7 Misrepresentation of pedigree.**
- 30-18-8 Killing unbranded cattle; killing, without bill of sale, cattle bearing brand of another person; penalty.**
- 30-18-9 Dog fighting and cockfighting; penalty.**
- 30-18-10 Exclusion.**
- 30-18-11 Unlawful tripping of an equine; exception.**
- 30-18-12 Injury to livestock.**
- 30-18-13 Injury to a police dog, police horse or fire dog; harassment of a police dog, police horse or fire dog.**
- 30-18-14 Livestock crimes; livestock inspectors to enforce.**
- 30-18-15 Intracardiac injection prohibited on conscious animal.**

- D. Protective gear and appropriate animal handling equipment should be readily available to employees.
- E. Shelter personnel should wash their hands frequently in order to protect themselves and the animals. Hand sanitizers, first aid kits, and eyewash stations should be made available to all employees, volunteers, and visitors.

**12. ADOPTION STANDARDS**

- A. Shelters should establish adoption fees. A responsible adoption program should be developed and implemented. In the event a shelter decides to waive specific adoption fees, the shelter must use appropriate adoption guidelines as described below to ensure the adopter is qualified to own a pet.
- B. Shelters should develop criteria for potential adopters and for unsuitable adopters. Adopters should sign a contract under which they agree to provide a specified level of care.
- C. Shelters should learn temperament-testing procedures to ensure that animals are "fit" for adoption and to facilitate the best possible match between adopters and animals. (Please see Shelter Resource List on pages 20-21.)
- D. Adoption screening program should include discussion of whether the animal and potential adopter are suitable for each other.
- E. In the event shelters offer animals for adoption that have not been pre-sterilized, the shelter must comply with New Mexico state law **NMSA 1978 § 77-1-20**:

**§ 77-1-20. Sterilization agreement and sterilization deposit required**

- A. No animal shall be released from an animal shelter to an adopting person unless a sterilization agreement has been signed and a sterilization deposit has been paid, as provided in Subsections C and D of this section.
- B. In addition to any adoption fee charged, a sterilization deposit of at least twenty-five dollars (\$25.00) shall be imposed on the adoption of each animal from an animal shelter.
- C. Animals less than six months of age shall be released only upon payment of the adoption fee and a sterilization deposit and after the adopting person has signed an agreement stating he will have the adopted animal sterilized when it is no older than six months of age.
- D. Adult animals over the age of six months shall be released only upon payment of the adoption fee and a sterilization deposit and after the adopting person has signed an agreement stating he will have the animal sterilized within thirty days of the date of adoption.



E. Any required sterilization deposit shall be reimbursed only upon presentation by the adopter of a valid receipt from a veterinarian proving that the animal was sterilized within the required time period.

F. An unsterilized animal reclaimed by its owner may be released without being sterilized upon minimum payment of the twenty-five dollars (\$25.00) for the sterilization deposit and impoundment fees imposed by the shelter, and the owner shall sign an agreement stating he/she will sterilize the animal within thirty days after release, obtain a breeder permit or its equivalent. The sterilization deposit shall be reimbursed only upon presentation by the owner of a valid receipt from a veterinarian proving that the animal was sterilized within the required time period.

- F. Policies should be developed and every care should be taken not to adopt, transfer, or release intact animals.
- G. Shelters should consider a program to microchip all adopted animals.
- H. Reasonable care should be taken to adopt or transfer only those animals free of disease and untreatable injury.
- I. Shelters should make every effort to work to place animals with recognized rescue organizations and responsible sanctuaries.

### 13. EUTHANASIA

- A. The legislature of the State of New Mexico passed the **Animal Sheltering Services Act [Chapter 77, Article 1B NMSA 1978]** in 2007 establishing the Animal Sheltering Services Board, since renamed the “Animal Sheltering Board” (ASB). The board was chartered with writing rules to govern the licensing of euthanasia agencies, certification of euthanasia instructors and euthanasia technicians and with the administration of humane euthanasia in New Mexico shelters. **Title 16, Occupational and Professional Licensing Chapter 24 Animal Sheltering, Parts 1 – 6** was approved by ASB on July 1, 2009. These rules have the effect of law and must be incorporated into the protocols and practices of all animal shelters that fall under its jurisdiction.

Therefore, the above cited rules for euthanasia are hereby incorporated into these recommended shelter standards. While these shelter standards are recommendations, the euthanasia rules are requirements.

## SHELTER RESOURCE LIST

A crucial responsibility of the Animal Sheltering Services Board will be to determine how to help animal shelters and shelter personnel throughout New Mexico obtain no-cost or extremely low-cost resources so that they can readily comply with the provisions of the Animal Sheltering Services Act. The following list represents suggested areas for the board to explore and suggested links for more information in a format that might be helpful to distribute to shelters or make available on the board's website, along with the shelter standards and euthanasia regulations:

### RULES AND REGULATIONS REGARDING ANIMAL SHELTERING

[www.rld.state.nm.us/animalsheltering](http://www.rld.state.nm.us/animalsheltering)

Animal Sheltering Services Act [Chapter 77, Article 1B NMSA 1978]

Title 16, Occupational and Professional Licensing Chapter 24 Animal Sheltering

City of Albuquerque, The Humane and Ethical Animal Treatment Ordinance (HEART)

[www.cabq.gov/pets/rules-tools/heart-ordinance](http://www.cabq.gov/pets/rules-tools/heart-ordinance)

### HOW-TO SERIES, STANDARD OPERATING PROCEDURES, BEHAVIORAL TRAINING, TEMPERAMENT TESTING, ADOPTION ISSUES

[www.hsus.org](http://www.hsus.org)

[www.americanhumane.org](http://www.americanhumane.org)

[www.nacanet.org](http://www.nacanet.org)

[www.animalsheltering.org](http://www.animalsheltering.org)

[www.AnimalBehaviorAssociates.com](http://www.AnimalBehaviorAssociates.com)

### TRAINING RESOURCES, PUBLICATIONS

[www.hsus.org](http://www.hsus.org)

[www.nacanet.org](http://www.nacanet.org)

[www.americanhumane.org](http://www.americanhumane.org)

[www.aspca.org](http://www.aspca.org)

[www.peta.org](http://www.peta.org)

[www.bestfriends.org](http://www.bestfriends.org)

### POUND SEIZURE IN NEW MEXICO

[www.banpoundseizure.org/home.shtml](http://www.banpoundseizure.org/home.shtml)

[www.idausa.org/facts/poundseizure.html](http://www.idausa.org/facts/poundseizure.html)

[www.peta.org/factsheet/files/FactsheetDisplay.asp?ID=33](http://www.peta.org/factsheet/files/FactsheetDisplay.asp?ID=33)

### EQUIPMENT, SUPPLIES, PHARMACEUTICALS

[www.animal-care.com](http://www.animal-care.com)

[www.deerskinanimalcontrol.com](http://www.deerskinanimalcontrol.com)

[www.vetmeddirect.com](http://www.vetmeddirect.com)

[www.shopmedvet.com](http://www.shopmedvet.com)

[www.spah.com](http://www.spah.com)

[www.medicalartspress.com](http://www.medicalartspress.com)

[www.twmedical.com](http://www.twmedical.com)

### SAMPLE FORMS, SOFTWARE

[www.animalsheltering.org](http://www.animalsheltering.org)

[www.hsus.org](http://www.hsus.org)  
[www.aspca.org](http://www.aspca.org)  
[www.bestfriends.org](http://www.bestfriends.org)

PUBLIC FUNDING FROM LOCAL/STATE SOURCES

[www.nmml.org](http://www.nmml.org)  
[www.nmcounties.org](http://www.nmcounties.org)  
[www.icma.org](http://www.icma.org)

PRIVATE FUNDING OPPORTUNITIES

[www.foundationcenter.org](http://www.foundationcenter.org)  
[www.bestfriends.org](http://www.bestfriends.org)

STATE STATUTES, CITY/COUNTY ORDINANCES

[www.nmlaws.org](http://www.nmlaws.org)  
[www.apnm.org](http://www.apnm.org)

SHELTER MEDICINE, SANITATION, NUTRITION, ENRICHMENT, EXERCISE

[www.sheltermedicine.com](http://www.sheltermedicine.com)  
[www.animalsheltering.org](http://www.animalsheltering.org)

DOG AND CAT BREED INFORMATION

[www.pets-place.net/BreedProfiles.html](http://www.pets-place.net/BreedProfiles.html)  
[www.dogbreedinfo.com](http://www.dogbreedinfo.com)  
[www.lovemypet.com](http://www.lovemypet.com)

NEW MEXICO BREED RESCUE GROUPS

[www.petroglyphsnm.org](http://www.petroglyphsnm.org)

NON-PROFIT BOARDS, FUNDRAISING, HUMAN RESOURCES, INSURANCE

[www.idealists.org](http://www.idealists.org)  
[www.managementhelp.org](http://www.managementhelp.org)  
[www.guidestar.org](http://www.guidestar.org)

**The following individuals and organizations provided invaluable assistance in compiling this document:**

**Carol Calista, DVM, Calista Animal Hospital, Las Cruces;**  
**Ellie Choate, former Supervisor, Doña Ana County Animal Control;**  
**The Humane Society of the United States;**  
**Leslie King, Community Programs Manager, Animal Protection of New Mexico;**  
**Elisabeth Jennings, Executive Director, Animal Protection of New Mexico;**  
**Bridget Lindquist, Executive Director, Española Valley Humane Society and Shelter;**  
**Jo McInerney, Animal Welfare Alliance, Roswell;**  
**Victoria Murphy, Animal Control Program Manager, Edgewood, New Mexico;**  
**National Animal Control Association;**  
**Michele Rokke, Santa Fe;**  
**Claudia Roll, Kennel Manager, City of Albuquerque, Animal Care Center;**  
**John Romero, DVM, City of Albuquerque, Animal Services Department;**  
**The Association of Animal Shelter Veterinarians;**  
**The University of California, Davis Koret Shelter Medicine Program;**  
**Peggy Weigle, Executive Director, Animal Humane | New Mexico;**  
**Barbara Yarborough, Director, Farmington Animal Control and Shelter;**  
**Gretchen Yost, DVM, Cottonwood Veterinary Clinic, Española.**

**Addendum D**  
**Resolution 16-22**  
**Establishing Fees for Services Provided by the City of Las Vegas**

**City of Las Vegas  
Resolution 16-22**

**A Resolution establishing fees for services provided by the City of Las Vegas Animal Shelter Contractor (Animal Welfare Coalition of Northeastern New Mexico) and repealing Resolution 09-48**

**WHEREAS, City of Las Vegas Code Chapter 118 Animals, Section 5(F) and Section 6 calls for the City to establish by resolution appropriate fees for services provided by the Animal Shelter; and**

**WHEREAS, the City has contracted the Animal Welfare Coalition of Northeastern New Mexico (AWC) to provide shelter management services; and**

**WHEREAS, the AWC has evaluated the services it provides and the costs associated with these services; and**

**WHEREAS, Resolution 09-48 previously established fees under provisions of City Code.**

**Now therefore be it resolved by the City Council, the Governing Body of the City of Las Vegas, that Resolution 09-48 is hereby repealed, and the following fees are hereby established:**

<b>Feed and Care</b>	<b>\$15.00/day</b>
<hr/>	
<b>Impound Fee</b>	
• First Intake	No Charge
• Second Intake (Fee increase of \$25.00 for each Intake thereafter)	\$25.00
<hr/>	
<b>Microchip</b>	<b>\$25.00</b>
<hr/>	
<b>DA2PPV (canine)</b>	<b>\$10.00</b>
<hr/>	
<b>Bordetella (canine)</b>	<b>\$10.00</b>
<hr/>	
<b>Felocell 4 (feline)</b>	<b>\$10.00</b>
<hr/>	
<b>Dewormer</b>	<b>\$5.00</b>
<hr/>	
<b>Flea/Tick Treatment</b>	<b>\$15.00</b>
<hr/>	

<b>Animal Surrender</b>	
• One (1) animal	\$25.00
• Litter	\$40.00
• Litter w/ mother	\$50.00

---

<b>Personalized ID Tag</b>	\$5.00
----------------------------	--------

---

<b>City License</b>	
• Vetted	\$2.00
• Intact	\$5.00

---

<b>Mass Cremation</b>	
• Under 40 pounds	\$10.00
• 40 to 80 pounds	\$15.00
• Over 80 pounds	\$20.00

---

<b>Private Cremation</b>	
• Small Animals (gerbits, ferrets, rabbits, etc.)	\$20.00
• Under 40 pounds	\$30.00
• 40 to 80 pounds	\$50.00
• Over 80 pounds	\$70.00

---

<b>Trap Rental</b>	
• Feline	\$5.00 (\$20.00 refundable deposit)
• Canine	\$5.00 (\$100.00 refundable deposit)

---

<b>Return to Owner</b>	
• Daily Feed & Care	\$15.00
• DA2PPV (canine)	\$10.00
• Bordetella (canine)	\$10.00
• Dewormer	\$5.00
• Felocell 4 (feline)	\$10.00
• Dewormer (feline)	\$5.00
• State Mandated Spay/Neuter Deposit	\$25.00
• License Fee based upon jurisdiction	TBD
• Vet Bill (if animal was injured prior to arriving at shelter and/or if animal was suffering from an illness/disease prior to arriving at shelter)	If Applicable

---

**Adoption Fees (All adoptions include: Microchip, Vaccinations, Deworm, Flea Tick Treatment, S/N Surgery, City License, Heartworm Test, or FIV/Felauk, 30 days of Pet Insurance, Starter Food)**

- Canine \$100.00-\$250.00
- Feline \$35.00
- Barn Cats Donation Suggested

---

**Private Dead Animal Pickup** N/A

---

**Veterinarian Quarantine Release** N/A

---

**Skunk Release (Personal Trap)** N/A

---

**PASSED, APPROVED AND ADOPTED** this 23 day of May, 2016.

  
Mayor Tonita Gurule-Giron

**ATTEST:**

  
Casandra Fresquez, City Clerk

**REVIEWED AND APPROVED AS TO LEGAL SUFFICIENCY ONLY:**

  
H. Chico Gallegos, City Attorney



**Addendum E**  
**Maintenance Procedures and Schedule**  
**External Waste Water Trough Maintenance and Care**

1. Always keep waste trough free and clear of all debris, including leaves and/or unwanted materials that would clog or otherwise obstruct flows.
2. Remove all unwanted materials around all drain screens, rinse trough thoroughly before beginning waste removal from kennels.
3. Flush all materials through unobstructed drain holes, if drain screens need to be removed for any reason replace as soon as possible.
4. Flush the main line to manhole every (3) days of operation using high water pressure. Remove drain screens and insert expandable water flow cleanout blaster as far into drain as possible. Flush for at least 10-15 minutes. Maintain the main line to manhole so it will remain clear at all times.
5. During winter months freezing will occur; keep drains in operating condition. Use methods that will not harm waste lines or animals.
6. Keep exterior hose-bib water line from freezing. Blow out hoses, and or drain them before next use. Wear personal protection equipment when working in icy-conditions.

**Addendum F**  
**Sample Animal Welfare Coalition Monthly Report**

[REDACTED]

### CITY OF LAS VEGAS MONTHLY REPORT

**NAME OF AGENCY:** The Animal Welfare Coalition

**REPORT FOR:** DATES HERE

**DATE SUBMITTED:**

**PREPARED BY:**

**PHONE:**

#### ANIMAL MANAGEMENT STATISTICS

1. The total number of new animals who received services by the AWC for the month. \_\_\_\_\_
2. The total number of animals (both new and ongoing) New \_\_\_\_\_ Ongoing \_\_\_\_\_
3. Total income from contracted services

City \_\_\_\_\_

County \_\_\_\_\_

Total \_\_\_\_\_

4. Total Income from other sources such as:

Surrender Fees	
Return To Owner Fees	
City License	
County License	
Impound Fees	
Adoptions	
Trap Rentals	
Microchipping	
ID Tags	
Vaccines	
Private Cremation	
Mass Cremation	
Retail	
Anti-Tether Fines	
Donations	
Fundraisers	
Other	
<b>Total Income</b>	

5. Total costs of providing shelter services: \_\_\_\_\_

Service Categories		
Vaccines		
Medical Supplies		
Veterinarian Services		
Food		
Litter		
Transport		
Payroll and Payroll Taxes		
Maintenance		
Improvements & Upgrades		

Office		
Insurance		
Equipment		

**AGENCY FINANCIAL INFORMATION**

- 6. List any community services / events provided such as educational, outreach, public relations, vouchers, or other:
  
- 7. List any fundraising, grants/proposals, submitted or received for the month:
  
- 8. List any activities (such as meetings, MOUs, etc) which assisted the coordination of service with other agencies, or improved relationships among agencies (quantify if possible):
  
- 9. Activities or other pertinent information that should be made part of the records of the City of Las Vegas, such as major policy decisions of the AWC Board:
  
- 10. Attach financial statements, PetPoint inventory analysis, etc
- 11. Has the AWC observed any special needs or requests for services from the community for which the AWC was unable to provide by way of service or referral.

Yes \_\_\_\_\_ No \_\_\_\_\_

If yes, please explain

## Addendum G Collection, Retainment and Use of Fees Schedule

The parties hereby do mutually agree that the fees as adopted by the City shall be collected and retained according to the Collection and Retainment Schedule below. Any and all fees collected by the Contractor shall be used solely for the maintenance and care of animals housed at the City of Las Vegas Animal Shelter.

<b>Type of Fee</b>	<b>Price</b>	<b>Collected &amp; Retained</b>
Feed & Care	\$15.00/Day	Animal Welfare Coalition
<b><u>IMPOUND FEE</u></b>		
First Intake	No Charge	
Second Intake (Fee increase of \$25.00 for each intake thereafter)	\$25.00	City of Las Vegas
Microchip	\$25.00	Animal Welfare Coalition
DA2PPV (canine)	\$10.00	Animal Welfare Coalition
Bordetella (canine)	\$10.00	Animal Welfare Coalition
Felocell f (feline)	\$10.00	Animal Welfare Coalition
Dewormer	\$5.00	Animal Welfare Coalition
Flea/Tick Treatment	\$15.00	Animal Welfare Coalition
<b><u>ANIMAL SURRENDER</u></b>		
One (1) Animal	\$25.00	Animal Welfare Coalition
Litter	\$40.00	Animal Welfare Coalition
Litter w/Mother	\$50.00	Animal Welfare Coalition
Personalized ID Tag	\$5.00	Animal Welfare Coalition
<b><u>CITY LICENSE</u></b>		
Vetted	\$2.00	City of Las Vegas
Intact	\$5.00	City of Las Vegas
<b><u>MASS CREMATION</u></b>		
Under 40 lbs.	\$10.00	City of Las Vegas
40 - 80 lbs.	\$15.00	City of Las Vegas
Over 80 lbs	\$20.00	City of Las Vegas

<b>Type of Fee</b>	<b>Price</b>	<b>Collected &amp; Retained</b>
<b><u>PRIVATE CREMATION</u></b>		
Small Animals (gerbils, ferrets, rabbits, etc.)	\$20.00	City of Las Vegas
Under 40 lbs.	\$30.00	City of Las Vegas
40 - 80 lbs.	\$50.00	City of Las Vegas
Over 80 lbs	\$70.00	City of Las Vegas
<b><u>TRAP RENTAL</u></b>		
Feline	5.00 (\$20.00 refundable deposit)	Animal Welfare Coalition
Canine	5.00 (\$100.00 refundable deposit)	Animal Welfare Coalition
<b><u>RETURN TO OWNER</u></b>		
Daily Feed & Care	\$15.00/Day	Animal Welfare Coalition
DA2PPV (canine)	\$10.00	Animal Welfare Coalition
Bordetella (canine)	\$10.00	Animal Welfare Coalition
Dewormer	\$5.00	Animal Welfare Coalition
Felocell (feline)	\$10.00	Animal Welfare Coalition
Dewormer (feline)	\$5.00	Animal Welfare Coalition
State Mandated Spay/Neuter Deposit	\$25.00	Animal Welfare Coalition
License Fee based upon jurisdiction	TBD (per Resolution 16-22)	Animal Welfare Coalition
Vet Bill (if animal was injured prior to arriving at shelter and/or if animal was suffering from an illness/disease prior to arriving at shelter)	If Applicable	Animal Welfare Coalition
<b><u>ADOPTION FEES</u></b>		
Canine	\$100.00 - \$250.00	Animal Welfare Coalition
Feline	\$35.00	Animal Welfare Coalition
Barn Cats	Donation Suggested	Animal Welfare Coalition

**Work Session**

**CITY COUNCIL MEETING AGENDA REQUEST**

**DATE: 12/28/16**

**DEPT: City Clerk**

**MEETING DATE: 1/11/17**

**DISCUSSION ITEM/TOPIC: Open Meeting Resolution 17-01**

**BACKGROUND/RATIONALE:** Resolution 17-01 establishes reasonable notice of Council Meetings in compliance with the Open Meetings Act. Approval of the resolution is required annually.

**THIS REQUEST FORM MUST BE SUBMITTED TO THE CITY CLERK'S OFFICE NO LATER THAN 5:00 P.M. ON FRIDAY ONE AND A HALF WEEKS PRIOR TO THE CITY COUNCIL MEETING.**

  
SUBMITTER'S SIGNATURE

**REVIEWED AND APPROVED BY:**

  
TONITA GURULÉ-GIRÓN  
MAYOR

  
RICHARD TRUJILLO  
CITY MANAGER

\_\_\_\_\_  
ANN MARIE GALLEGOS  
FINANCE DIRECTOR  
(PROCUREMENT)

\_\_\_\_\_  
PURCHASING AGENT  
(FOR BID/RFP AWARD)

\_\_\_\_\_  
H. CHICO GALLEGOS  
CITY ATTORNEY  
(ALL CONTRACTS MUST BE  
REVIEWED)

**CITY OF LAS VEGAS  
RESOLUTION NO. 17-01**

**A RESOLUTION ESTABLISHING REASONABLE NOTICE OF CITY COUNCIL MEETINGS IN COMPLIANCE WITH THE OPEN MEETINGS ACT; RESCINDS AND REPLACES ALL PREVIOUS CITY OF LAS VEGAS RESOLUTIONS REGARDING "REASONABLE NOTICE OF CITY COUNCIL MEETINGS IN COMPLIANCE WITH THE OPEN MEETINGS ACT."**

**Whereas**, Section 10-15-1 (B) of the Open Meetings Act (NMSA 1978, Sections 10-15-1 to 10-15-4) provides that, except as may be otherwise provided in the New Mexico Constitution or the provisions of the Open Meetings Act, all meetings or a quorum of members of any board, council, commission, administrative adjudicatory body or other policy-making body of any state or local public agency held for the purpose of formulating public policy, discussing public business or for the purpose of taking any action within the authority of or the delegated authority of such body are declared to be public meetings open to the public at all times; and

**Whereas**, any meetings subject to the Open Meetings Act at which the discussion or adoption of any proposed resolution, rule, regulation or formal action occurs and at which a majority of a quorum of the body is in attendance, and any closed meeting shall be held only after reasonable notice to the public; and

**Whereas**, Section 10-15-1 (D) of the Open Meetings Act requires the City council to determine at least annually what constitutes reasonable notice of its public meetings;

**NOW, THEREFORE, BE IT RESOLVED BY THE CITY COUNCIL OF THE CITY OF LAS VEGAS, NEW MEXICO, THAT;**

**1. Regular Business Meeting.** Pursuant to Section 14-7 (A) of the Municipal Code, all Regular Business Meetings of the Las Vegas City Council shall be held on the third Wednesday of each month at 6:00 p.m. at the City Council Chambers, 1700 North Grand Avenue, Las Vegas, New Mexico. The agenda will be available at least seventy-two hours prior to the meetings from the City Clerk whose office is located at the George Arellanes Municipal Complex, 1700 North Grand Avenue, Las Vegas, New Mexico. Notice of said meetings shall be printed in a newspaper(s) of general circulation one (1) time, at the beginning of the calendar year; and shall be telephoned, e-mailed or faxed to broadcast stations licensed by the federal communications commission and newspapers of general circulation that have provided a written request for such notice. If a regular meeting is postponed, notice of the new time and date of said meeting may be printed in a newspaper(s) of general circulation; and shall be telephoned, emailed or faxed to broadcast stations licensed by the federal communications commission and newspapers of general circulation that have provided a written request for such notice at least seventy-two hours to the specific time of the meeting or at the earliest date and time possible. If the date and time of the Regular meeting permanently changed, the new date and time shall be printed in a newspaper(s) of general circulation twice, one (1) week apart.

**2. Work Sessions.** Work Sessions shall be held for the purpose of examining issues, but no official action may be taken on the second Wednesday of each month at 5:30 p.m. at the City Council Chambers, 1700 North Grand Avenue, Las Vegas, New Mexico. The agenda will be available at least seventy-two hours prior to the work session from the City Clerk whose



office is located at the George Arellanes Municipal Complex, 1700 North Grand Avenue, Las Vegas, New Mexico. Notice of said work session shall be printed in a newspaper(s) of general circulation one (1) time, at the beginning of the calendar year; and shall be telephoned, e-mailed or faxed to broadcast stations licensed by the federal communications commission and newspapers of general circulation that have provided a written request for such notice. If a work session is postponed, notice of the new time and date of said work session may be printed in a newspaper(s) of general circulation; and shall be telephoned, emailed or faxed to broadcast stations licensed by the federal communications commission and newspapers of general circulation that have provided a written request for such notice at least seventy-two hours prior to the specific time of the meeting or at the earliest date and time possible. If the date and time of the work session is permanently changed, the new date and time shall be printed in a newspaper(s) of general circulation twice, one (1) week apart.

**3. Other Meetings Not Regularly Scheduled.** Special meetings may be called by the Mayor or a majority of the members of the City Council by giving notice to each member of the Council, personally served or left at his/her usual place of residence seventy-two hours prior to the meeting. Notice of said special meeting may be printed in a newspaper(s) of general circulation at least seventy-two hours before the meeting date or on the earliest date possible prior to the date of the meeting. Notice of said special meeting shall be telephoned, emailed or faxed to broadcast stations licensed by the federal communications commission and newspapers of general circulation that have provided a written request for such notice for public announcement at least seventy-two hours prior to the specific time of the meeting or on the earliest date possible prior to the time of the meeting.

**4. Emergency Meetings.** Emergency meetings shall be called only under unforeseen circumstances which demand immediate action to protect the health, safety and property of citizens or to protect the public body from substantial financial loss. The City Council will avoid emergency meetings whenever possible. Emergency meetings may be called by the Mayor or a majority of the members upon notice as practical under the circumstances. If time permits, notice of said meeting may be printed in a newspaper(s) of general circulation on the earliest date possible as soon as the meeting is called. If time permits, notice of said meeting shall also be telephoned, emailed or faxed to broadcast stations licensed by the federal communications commission and newspapers of general circulation that have provided a written request for such notice for public announcements on the earliest date and time possible prior to the time of the meeting. The notice for emergency meetings shall include an agenda for the meeting or information on how the public may obtain a copy of the agenda.

5. All notices shall include an agenda for the meeting or information on how members of the public may obtain a copy of the agenda. The agenda shall be available to the public at least seventy-two hours before any meeting or at the earliest possible time in case of emergency meetings. The City Council may be flexible on agenda postings under considerable circumstances.

6. The City Council may close a meeting to the public if the subject matter of such discussion or action is exempt from the open meetings requirement pursuant to NMSA Section 10-15-1(H) of the Open Meetings Act.

(a) If any meeting is closed during an open meeting, such closure shall be approved by a majority vote of a quorum of the City Council taken during the open meeting. The authority for the closed meeting and the subjects to be discussed shall be stated with reasonable specificity in the motion to close and the vote of each individual member on the motion to close shall be recorded in the minutes. Only those subjects specified in the motion may be discussed in the closed meeting.

(b) If a closed meeting is conducted when the City Council is not in an open meeting, the closed meeting shall not be held until public notice, appropriate under the circumstances, stating the specific provision of law authorizing the closed meeting and the subjects to be discussed with reasonable specificity is given to the members and to the general public.

(c) Following completion of any closed meeting, the minutes of the open meeting that was closed, or the minutes of the next open meeting if the closed meeting was separately scheduled, shall state whether the matters discussed in the closed meeting were limited only to those specified in the motion or notice for closure.

(d) Except as provided in NMSA Section 10-15-1(H) of the Open Meetings Act, any action taken as a result of discussion in a closed meeting shall be made by vote of the City Council in an open meeting.

7. The regular scheduled meetings of the City of Las Vegas' Permanent Boards and Commissions, Advisory Boards and Committees are as follows:

- Planning & Zoning Commission/Board of Adjustments – Last Monday of the month at 4:00 p.m. – City Council Chambers;
- Design Review Board – 3<sup>rd</sup> Monday of the month at 4:00 p.m. – City Council Chambers;
- Lodger's Tax Advisory Board – (Quarterly), (January, April, July, October) 2<sup>nd</sup> Tuesday of the month at 2:00 p.m. – City Council Chambers;
- Police Advisory Commission – 3<sup>rd</sup> Thursday of the month at 1:15 p.m. – Police Department;
- Extra-Territorial Zoning Authority – Last Tuesday of the month at 4:00 p.m. – City Council Chambers;
- Extra-Territorial Zoning Commission – 3<sup>rd</sup> Tuesday of the month at 4:00 p.m. – City Council Chambers;
- Public Housing Authority Board of Commissioners – 3<sup>rd</sup> Wednesday of each month at 5:30 p.m. – City Council Chambers;
- Labor Management Relations Board – Meeting will be scheduled and published as required by ordinance, rules and regulations;
- Campaign and Ethics Board – Meeting will be scheduled and published as required;

- Library Board – (Quarterly), (January, April, July, October) Last Tuesday of the month at 10:00 a.m. – Carnegie Library;
- Museum Board – (Quarterly), (February, May, August, November) 2<sup>nd</sup> Thursday of the month at 5:00 p.m. – Las Vegas Museum & Rough Riders Memorial Collection;
- Tree Board – Last Tuesday of the month at 3:00 p.m. – Tierra Y Montes Conference Room;
- Film Commission – (Quarterly), ( January, April, July, October) 1<sup>st</sup> Wednesday of the month at 4:00 p.m. – City Council Chambers;
- Charter Commission – Meeting will be scheduled and published as required;
- Youth Advisory Committee – Meeting will be scheduled and published as required;
- Finance Advisory Committee – Last Thursday at 3:30 p.m. the month following the end of the quarter ( April, July, October) – City Council Chambers;
- Utility Advisory Committee – 2<sup>nd</sup> Tuesday of the month at 1:30 p.m. – Utilities Department;
- Housing Advisory Committee – Last Wednesday of the month at 10:00 a.m. – City Council Chambers;
- Recreation Advisory Committee – (Quarterly), (February, May, August, November) 2<sup>nd</sup> Monday of the month at 4:00 p.m. – City Council Chambers;
- Senior Center Advisory Committee – 3<sup>rd</sup> Wednesday of the month at 10:00 a.m. – Las Vegas Senior Center;
- Veteran’s Advisory Committee -

This Resolution shall be published in a newspaper(s) of general circulation twice, one (1) week apart after its adoption.

Done this \_\_\_\_ day of \_\_\_\_\_ 2017.

\_\_\_\_\_  
 Mayor Tonita Gurulé-Girón

ATTEST:

\_\_\_\_\_  
 Casandra Fresquez, City Clerk

Approved as to Legal Sufficiency Only:

Work Session

**CITY COUNCIL MEETING AGENDA REQUEST**

DATE: 01/03/17

DEPT: Utilities Dept.

MEETING DATE: 01/11/17

**DISCUSSION ITEM/TOPIC:** Resolution No. 16-45 establishing a convenience fee for credit and debit card payment transactions.

**BACKGROUND/RATIONALE:** The City of Las Vegas does not currently charge a fee for customers to make payments with a credit or debit card which is costing the City approximately \$2,700 per month. Assessing a fee of \$1.25 per transaction will partially offset this expense.

**THIS REQUEST FORM MUST BE SUBMITTED TO THE CITY CLERK'S OFFICE NO LATER THAN 5:00 P.M. ON FRIDAY ONE AND A HALF WEEKS PRIOR TO THE CITY COUNCIL MEETING.**

  
SUBMITTER'S SIGNATURE

REVIEWED AND APPROVED BY:

  
TONITA GURULE-GIRON  
MAYOR

  
RICHARD TRUJILLO  
CITY MANAGER

\_\_\_\_\_  
ANN MARIE GALLEGOS  
FINANCE DIRECTOR  
(PROCUREMENT)

\_\_\_\_\_  
PURCHASING AGENT  
(FOR BID/RFP AWARD)

\_\_\_\_\_  
H. CHICO GALLEGOS  
CITY ATTORNEY  
(ALL CONTRACTS MUST BE  
REVIEWED)

**CITY OF LAS VEGAS  
RESOLUTION NO. 16-45**

**A RESOLUTION ESTABLISHING A CONVENIENCE FEE FOR CREDIT AND DEBIT CARD TRANSACTIONS OFFSETTING TRANSACTION FEES CHARGED BY CREDIT CARD COMPANIES**

**WHEREAS**, the City of Las Vegas Utilities Department is currently absorbing transaction fees charged by credit card companies; and

**WHEREAS**, such transaction fees cost the Utilities Department an estimated \$2,700 per month; and

**WHEREAS**, that cost will rise along with the volume of credit and debit card transactions as online bill pay is made available to utilities customers; and

**WHEREAS**, it is common practice for government agencies to offset the expense of credit and debit card transactions by charging a fully disclosed convenience fee; and

**WHEREAS**, a \$1.25 per transaction fee will partially offset the expense incurred by the city for processing credit and debit card payments.

**NOW, THEREFORE, BE IT RESOLVED BY THE GOVERNING BODY OF THE CITY OF LAS VEGAS, NEW MEXICO, THAT:**

1. The City hereby establishes a convenience fee of \$1.25 per transaction for customers choosing to pay their utility bills by credit or debit card.
2. This resolution shall be in effect five days after its passage and publication.

PASSED, APPROVED and ADOPTED this \_\_\_\_\_ day of \_\_\_\_\_, 2017.

\_\_\_\_\_  
Mayor Tonita Gurulé-Girón

ATTEST:

\_\_\_\_\_  
Casandra Fresquez, City Clerk

APPROVED AS TO LEGAL SUFFICIENCY ONLY

\_\_\_\_\_  
H. Chico Gallegos, City Attorney

**Work Session**

**CITY COUNCIL MEETING AGENDA REQUEST**

**DATE:** 12/30/16

**DEPT:** Utilities Dept.

**MEETING DATE:** 01/11/17

**DISCUSSION ITEM/TOPIC:** Amendment to Bradner Dam Rehabilitation project scope of work.

**BACKGROUND/RATIONALE:** Upon completion of the Bradner Preliminary Engineering Report the engineer will obtain permit, design, produce bid documents and supply construction phase engineering services for the Bradner Dam Rehabilitation project. This amendment defines the responsibilities and costs associated with those tasks.

**THIS REQUEST FORM MUST BE SUBMITTED TO THE CITY CLERK'S OFFICE NO LATER THAN 5:00 P.M. ON FRIDAY ONE AND A HALF WEEKS PRIOR TO THE CITY COUNCIL MEETING.**

  
SUBMITTER'S SIGNATURE

**REVIEWED AND APPROVED BY:**

  
TONITA GURULÉ-GIRÓN  
MAYOR

  
RICHARD TRUJILLO  
CITY MANAGER

\_\_\_\_\_  
ANN MARIE GALLEGOS  
FINANCE DIRECTOR  
(PROCUREMENT)

\_\_\_\_\_  
PURCHASING AGENT  
(FOR BID/RFP AWARD)

\_\_\_\_\_  
H. CHICO GALLEGOS  
CITY ATTORNEY  
(ALL CONTRACTS MUST BE  
REVIEWED)

Revised 4/20/16



**UTILITIES DEPARTMENT PROJECT SUMMARY SHEET**

**PROJECT NAME:** Bradner Dam Rehabilitation  
**PROJECT ENGINEER:** AECOM  
**PROJECT MANAGER:** Marvin Cordova

**PROJECT NUMBER:** UT-WS-2013-4  
**CONTRACT NUMBER:** 2716-13

**PROJECT DESCRIPTION:** The Bradner Reservoir Rehabilitation will consist of a minor raise to the existing main and auxiliary dam embankments and an upgrade to the existing outlet works comprising of a new intake tower and modification to the existing outlet conduit that will be located on the left abutment of the main or auxiliary dam embankment. Additionally an upgrade to the existing spillway will comprise of raising the existing chute walls and modification to the existing stilling basin and crest structure.

**ACTION TIMELINE:** 2017-2018

**FUNDING SOURCES**

City Funds \$0  
 Capital Appropriations \$ 4,000,000.00  
 Capital Appropriations \$ 6,000,000.00  
 Total \$10,000,000.00

**ESTIMATED EXPENDITURES**

Design:  
 Engineering Services: \$1,695,170.00  
 Construction: \$7,000,000.00  
 Total: \$8,695,170.00

**LINE ITEM NUMBER:** 646-0000-650-8741

<b>ACTION</b>	<b>DESCRIPTION</b>	<b>DATE</b>
<b>Loan/Grant</b>	Capital Appropriations # 14-2158 \$4.0M Capital Appropriations # 14-1587 \$6.0M	08/30/14 03/25/15
<b>Authorized Ordinance</b>		
<b>Loan/Subsidy Agreement</b>		
<b>Engineering Services Agreement</b>	Bradner PER w/AECOM	06/08/2016
<b>Bid Document Review</b>	NA	
<b>RFB Advertised</b>	NA	
<b>RFB Opening</b>	NA	
<b>Engineers Recommendation</b>	NA	
<b>Committee Recommendation</b>		
<b>Council Approval</b>	Item taken to City Council for Approval	
<b>Notice to Proceed</b>		

**Amendment**  
**Bradner Dam Rehabilitation Project**  
**Environmental, Design and Construction Engineering Services**  
Scope of Work, Schedule, and Budget

## **Scope of Work**

The following scope of work is to obtain the required environmental permit, perform the required design and gain approval and construction permit from the New Mexico Office of the State Engineer (OSE), and perform construction engineering services for the rehabilitation of Bradner Dam. The design and construction phase services will be in conformance with OSE Dam Safety Rules and Regulations. If required the presented scope of work will be revised based on the findings of the Preliminary Engineering Report that URS is presently preparing for the project.

### **Task 1.0 - Project Management**

URS will perform project management activities to support completion of project. Project management activities will include contract administration, coordination of URS' team, coordination with the City and others, development, and implementation of a quality assurance and control process, development and maintenance of the project design schedule, and communication of project status and issues for prompt resolution with the City. URS' Project Manager, Ed Toms, will attend scheduled meetings as detailed below to accomplish the project goals.

URS' Project Manager will schedule and conduct a kick-off meeting within 15 days of receipt of the Notice to Proceed with the Project. The primary agenda item to be addressed during the kick-off meeting shall be the project management plan and alternatives developed for this proposal. Services performed by URS and construction documents prepared by URS will be in conformance with the requirements of OSE Rules. Specific project management activities included in this scope of services are detailed in the following tasks:

#### **Task 1.1 - Project Management Plan**

URS will prepare a Project Management Plan that will serve as a guide and describe the work plan, schedule, budgets, and other project details. The Project Management Plan shall include a project overview, a copy of this scope of services along with task and subtask budget breakdowns, a summary of project objectives, the project organization and responsibilities, a contact list, a description of project communication guidelines, a preliminary project schedule, and a narrative description of critical task sequencing and linking logic that is embedded into the project schedule to easily identify critical points and milestones that may affect the overall schedule. The draft Project Management Plan will be reviewed at the kick-off meeting.

#### **Deliverables:**

- Draft and final Project Management Plans and kick-off meeting minutes.

#### **Task 1.2 - Quality Assurance/Quality Control Program**

URS' Project Manager shall establish and monitor the project Quality Assurance/Quality Control (QA/QC) procedures and milestones. A QA/QC plan will be prepared detailing major submittals and their reviews prior to submittal. This QA/QC plan will be included with the Project Management Plan.

#### **Deliverables:**

- Draft and final QA/QC Plans.



### **Task 1.3 - Project Schedule Development, Maintenance, and Reporting**

URS will develop a detailed project schedule using MS Project to manage our efforts. The draft schedule will be presented at the kick-off meeting. The schedule will be updated as needed, or otherwise required. Schedule status will be reported on a monthly basis by hard copy schedule updates as a part of invoicing.

#### **Deliverables:**

- Initial and monthly project schedule updates in hard copy and electronic (.mpp) format.

### **Task 1.4 - Budget Monitoring and Reporting**

The detailed project schedule will be cost and resource loaded by task, allowing URS' Project Manager to monitor actual project progress by task against the scheduled progress. Each task budget will be updated on a biweekly basis and reported by URS on a monthly basis as a part of invoicing.

#### **Deliverables:**

- Monthly budget updates with invoicing.

### **Task 1.5 - Invoicing and Progress Reporting**

URS' Project Manager shall submit an invoice at milestone deliverables. The accompanying budget status report will indicate level of completion for each task through the end of the invoice billing period.

#### **Deliverables:**

- Monthly invoices and progress reports.

#### **Assumptions:**

- Project management is assumed as being approximately 8% of the sum of the fees for the environmental permitting, design and construction phase services.

## **Task 2 - Environmental Permitting Phase Services**

The following presents URS' scope of work to provide permitting support for the Project. The purpose of this work is to acquire the necessary environmental approvals from the U.S. Army Corps of Engineers (USACE) to construct the rehabilitation Project. The approvals are required based on our current understanding of the Project and the guidance URS received from the USACE (Ms. Deanna Cummings) on December 11<sup>th</sup> and December 16<sup>th</sup>, 2015 and October 4, 2016. The USACE requested that a Pre-Application meeting be held prior to commencement of permitting activities, ideally once the rehabilitation alternatives are identified. URS does not guarantee how the USACE, and other agencies, will respond to the City's request for permits. The services below are based on our past experience with similar projects, recent guidance from the USACE and may be modified based on the direction received at the Pre-Application meeting.

The following scope includes: 1) development of the necessary submittal documents for the authorization of a Clean Water Act Section 404 Individual Permit from the USACE and Section 401 Certification from the New Mexico Environment Department (NMED) 2) conduct activities required to satisfy National Environmental Policy Act (NEPA) compliance, and 3) conduct floodplain permitting activities including preparation of a Conditional Letter of Map Revision (CLOMR) submittal to FEMA.

### **Task 2.1 - Clean Water Act Section 404 and 401 Permitting**

URS obtained an Individual Permit for the Bradner Reservoir Enlargement Project (Application #SPA-2014-00049-ABQ). The USACE requested that the enlargement permit be withdrawn prior to initiating the rehabilitation project. URS will assist the City with the preparation of a permit withdrawal letter for the enlargement project under this task.

It is assumed that information from the engineering alternatives analysis and the following field surveys previously conducted at Bradner Reservoir can be used as a basis for impact assessment for the rehabilitation project:

Date Completed	Study Name	Company
January 2014	Bradner Reservoir Enlargement Wetland Findings Report	URS
January 2014	Cultural Resources Survey for the Quarry Location for the City of Las Vegas Bradner Reservoir Enlargement Project in San Miguel County, New Mexico	SWCA
November 2013	Cultural Resources Survey for the City of Las Vegas Bradner Reservoir Enlargement in San Miguel County, New Mexico	SWCA
November 2013	Biological Evaluation for the City of Las Vegas Bradner Reservoir Enlargement in San Miguel County, New Mexico	SWCA

URS will modify the information in the above reports by overlaying the proposed project area for the rehabilitation onto the wetlands, biological and cultural GIS data created for the enlargement project.

URS will prepare permitting documents and conduct the agency coordination necessary to obtain a Section 404 Individual Permit and 401 Certification for the rehabilitation project. Specifically, URS will:

- 1) Participate in a pre-application meeting with the USACE and determine the permitting requirements.
- 2) Prepare the following submittals:
  - a) A ENG Form 4345 application for an USACE Individual Permit for analysis of impacts from the rehabilitation project
  - b) A Section 404(b)1 guidelines compliance analysis
  - c) A wetland functional assessment
  - d) A Mitigation Plan for the Project describing compensation for impacts to wetland and surface water features
  - e) A list of adjacent landowners
  - f) A letter submittal requesting verification of analysis of effects to federally listed threatened and endangered species, including supporting documentation.
  - g) A letter submittal requesting verification of analysis of effects to historic and cultural resources
- 3) Coordinate with other agencies [e.g. Fish and Wildlife Service, State Historic Preservation Officer (SHPO), FEMA/San Miguel County] based on guidance from the Corps in an attempt to obtain regulatory clearances in relation to the 404 Permit.

#### Deliverables:

- Letter of Withdrawal for the existing Bradner Reservoir Enlargement permit
- Notes from the Pre-Application meeting

- An Individual Permit Application will be prepared and submitted to the USACE and the NMED, including the supporting documentation as described above.

### **Task 2.2 - NEPA Compliance**

Compliance with the National Environmental Policy Act (NEPA) is required for the rehabilitation project due to the federal nexus with filling jurisdictional waters of the U.S. The USACE will be the lead federal agency for NEPA compliance. Under this task, URS will prepare a Decision Document and submit it to the USACE for review. The Decision Document will consist of information pertaining to Purpose and Need, the Proposed Action, affected environment, impacts and mitigation. The USACE will validate the Decision Document and prepare a Finding of No Significant Impact (FONSI), assuming no significant impacts result from the rehabilitation project.

#### **Deliverable:**

- A Draft Decision Document will be prepared and submitted to the USACE for review

### **Task 2.3 - Floodplain Permitting and CLOMR**

Bradner Reservoir is shown as a Zone A floodplain area on Flood Insurance Rate Map on Panel 35047C0475D for San Miguel County, New Mexico and Incorporated Areas, dated December 3, 2010. It is anticipated that the proposed improvements associated with the Bradner Dam Rehabilitation Project will include construction within that Zone A regulatory floodplain.

San Miguel County participates in the National Flood Insurance Program (NFIP) and has adopted floodplain management criteria in the form of a Flood Damage Prevention Ordinance. Therefore, floodplain permitting coordination is required when any construction occurs within a mapped floodplain. Floodplain permitting is also a required element of the USACE's Section 404 permitting process.

In accordance with the minimum requirements of the NFIP, should the proposed improvements result in an increase or shift in the extents of the Zone A (100-year) floodplain shown on the FIRM, a CLOMR submittal to FEMA, to obtain the agency's comment on the proposed impacts of the project, is required. This scope assumes that a CLOMR submittal will be required.

Although these permitting processes were completed during the previous project for Bradner Reservoir, because the project components will change, the permitting work must be repeated based on the new proposed improvements.

San Miguel County has a prescribed floodplain permitting process that includes submittal of a permit application, along with supporting documentation and analyses. These same analyses and documentation would support a CLOMR request, should it be required. However, the CLOMR request would also require an application and submittal fee. URS will prepare Existing and Proposed Conditions hydrologic and hydraulic analyses for the 100-year flood event at Bradner Reservoir, map the resulting floodplains, and prepare the supporting documentation needed for the floodplain permit application and CLOMR submittal.

URS has prepared this scope based on the project information and permitting information available at this time. The estimate level of effort is based on that information and our experience completing this permitting process for the Bradner Reservoir Enlargement Project. This scope includes a limited amount of time to address one round of FEMA review comments on the CLOMR submittal. All preliminary review submittals will be made in electronic format. The FEMA CLOMR submittal will be made in electronic format, consistent with FEMA's online submittal requirements.

#### **Deliverable:**

- One hard copy of the final CLOMR submittal, each, to San Miguel County and the City.

**Assumptions:**

- No new field surveys will be conducted. Rather, the information collected from recent biological, wetlands and cultural surveys at Bradner Reservoir will be applied to the rehabilitation Project.
- The construction activities at Bradner Dam would be covered under an Individual Permit.
- There are no adverse impacts to federally listed T&E species and/or the Project will not impact critical habitat for any federally listed species.
- No migratory bird nest surveys are included in this scope of work.
- Up two meetings with the USACE (one Pre-Application meeting and one follow-up permitting status meeting, if needed).
- The Project will be in compliance with State water quality requirements and will not require additional consultation for Section 401 Certification.
- NEPA compliance will not include the preparation of an Environmental Assessment (EA) or Environmental Impact Statement (EIS).
- No other federal (i.e., access or special use permits, etc.) or state permitting will be required beyond obtaining a CLOMR.
- No more than 20 unique and significant comments will be received on the 404 Individual Permit.
- No hydrologic modeling will be required to assess stream depletions.
- No public meetings will be held.
- URS has included the \$7,000 initial review fee as a pass-through cost. FEMA’s current fee schedule indicates that additional review hours are charged \$60 per hour. As these costs cannot be estimated at this time, URS anticipates any additional charges will be paid directly by the City.

**Task 3 – Design Phase Services**

The design of the Bradner Reservoir Rehabilitation is envisioned to include the following main civil features:

- A minor embankment raise (up to 5 feet) to the existing main and auxiliary dam embankments
- An upgrade to the existing outlet works comprising of:
  - A new intake tower
  - Modification to the existing outlet conduit that will be located under the raised portion of the main embankment
- An upgrade to the existing spillway or the provision of a new spillway located on the left abutment of the main or auxiliary dam embankment

The design of both dams and other reservoir facility infrastructure will be in general accordance with New Mexico Office of the State Engineer Dam Safety Regulations (OSE, 2010) referred to herein as OSE Rules, and criteria set by the City.

**Assumptions:**

- Design will include analysis of project features, development of design drawings, technical specifications, and design report
- Design standards and criteria are the same or similar to the previous design efforts
- Allowance for client meetings as indicated. Additional meetings to be a change order
- ITR will be performed for drawings, calculations, design report, cost estimate and specifications and will be completed prior to the submission of the final design package

### **Task 3.1 - Geotechnical Design**

The main dam and auxiliary dam will be raised as required (up to 5 feet) in a downstream raise configuration. The raise is envisioned to be constructed mainly of on-site material borrowed from within the reservoir basin, excavations and from the borrow areas to the south and west of the reservoir. The designs will be based on previous and currently underway geotechnical investigations and site inspections. The height of the embankment raise will be confirmed in the PER.

#### **Assumptions:**

- Material properties will be based on field investigations performed to date and being performed currently. No additional field investigations are envisioned to be required to complete the design at this time. This will however be confirmed during the design process
- The Peak Ground Acceleration (PGA) for the site is assumed to be 0.15g (approximately a 5000-year return period)
- Design effort will include completion of new geotechnical analysis
- The analysis will be described in the design report

### **Task 3.2 - Hydraulic Design**

#### **Task 3.2.1 - Spillway**

The spillway component of the Project is yet to be defined. A preferred spillway alternative will be available following the development of the PER. The spillway is likely to either be an upgrade to the existing spillway or a new spillway located on the left abutment of either the main dam or the auxiliary dam.

An upgrade to the existing spillway would likely comprise of raising the existing chute walls and modification to the existing stilling basin and crest structure. A new spillway would likely comprise of a crest control structure, a chute and a stilling basin.

The spillway will be designed to pass the revised spillway design flood which will be documented in the revised hydrology study currently being undertaken. Freeboard from the spillway design flood to the embankment crests stipulated by the OSE Rules will be provided. The existing normal water surface and spillway crest elevation will be maintained. If required a new spillway exit channel will be designed.

#### **Task 3.2.2 - Outlet Works**

The rehabilitation of the outlet works is assumed to include the following:

- A new intake tower with a guard gate and three external gates with trash racks
- A new bridge from the main embankment crest to the intake tower
- Analysis of the existing outlet conduit to evaluate its suitability for the rehabilitation design
- Modification to the existing outlet conduit (if required) that will be located under the raised portion of the main embankment
- A new access vault (if required) downstream of the raised portion of the embankment

The intake tower and the outlet conduit will be designed in accordance with USBR methodology. The existing outlet conduit will be checked against the OSE Rules and in particular with respect to the reservoir drain time.

#### **Assumptions:**

- That the existing spillway is in adequate condition to permit an upgrade

- That the existing outlet conduit is adequate for the rehabilitation to resist the loads from the existing and the raised portion of the main embankment

### **Task 3.3 - Structural Design**

#### ***Task 3.3.1 - Intake Tower***

The intake tower is at this stage assumed to be located near the upstream toe of the embankment where there is assumed to be an adequate foundation and the ability to tie into the existing conduit through the dam. The intake tower will include multiple gate openings (total of three gates, excluding the guard gate). The intake tower access will be provided from the dam crest by a prefabricated steel bridge. The intake tower gates will be controlled from the top of the intake tower. The conduit vent pipe will be cast into the intake tower. The staff gauge for reservoir will be mounted on the face of the intake tower where it can be read from the bridge or dam crest. Trashracks will be installed at the three exterior gate openings. The trashrack will be sized to accommodate the design flow.

The intake tower structure will be considered for usual, unusual, and extreme loading conditions. Some structures could have more than one usual, unusual, or extreme loading condition, whereas other structures a loading condition could be eliminated by inspection.

The intake tower will be designed using guidance from the U.S. Army Corps of Engineers (USACE), American Concrete Institute (ACI), and American Institute of Steel construction (AISC).

#### ***Task 3.3.2 - Conduit and Conduit Encasement***

Depending on the final location of the intake tower, additional conduit could be required to connect to the existing conduit or a new outlet conduit could be required. Any new conduit (steel pipe) will be encased with concrete. Any conduit extension or replacement would be designed for compatibility with the existing conduit. If the existing conduit is utilized it may be slip-lined with a new conduit and grouted in place between the existing and new conduit. The existing conduit beneath the raised portion of the dam will be concrete encased as required and will terminate at a new access vault (if required) located at the downstream toe of the raised dam. The access vault would provide access to the conduit for inspection (remote) purposes and would likely include a new stop valve. The existing conduit will be analyzed for increased loading, but is assumed to be adequate. The condition of the existing conduit will be verified as the first task to be undertaken as part of the final design. The verification will include a video inspection of the existing conduit and the confirmation of the existing conduit concrete encasement both upstream and downstream of the dam via visual inspection. The location of the conduit just beyond the projected downstream dam toe and the existing intake location will be surveyed. The survey will also include the modified portion of the diversion ditch and the locations of recently completed geotechnical investigations, known valves on the reservoir outlet conduit, the culvert beneath Highway 65 and other additional survey points to be determined at the time of the survey.

The conduit and conduit encasement will be analyzed and designed using portions of ACI, USACE, AISC, and AWWA. The analysis of the conduit encasement will be determined using the Bureau of Reclamation's Beggs Deformeter Stress Analysis of Single-Barrel Conduits.

#### ***Task 3.3.3 - Spillway Structure***

The existing upgraded, or the new spillway, will be considered for usual, unusual, and extreme loading conditions. Some structures could have more than one usual, unusual, or extreme loading condition, whereas other structures could have a loading condition that can be eliminated by inspection (no detailed calculation required).

#### **Assumptions:**

- All structures can be founded on rock foundation
- Where material properties are unknown, conservative assumptions will be applied

- The existing conduit is adequate for the rehabilitation and does not require any upgrade. Modification at connection points upstream and downstream of the dam can be made, but sections within the dam are adequate
- Subcontractor costs are approximately as shown in the enclosed fee estimate
- The Peak Ground Acceleration (PGA) for the structures is assumed to be 0.15g (approximately a 5000-year return period)

#### **Task 3.4 - Access Roads**

The existing access roads are to be modified as part of the rehabilitation to provide access to the raised dam crests. Only minor modifications are envisioned to be necessary in the area local to the existing dam crests (not to extend more than 50 feet from the raised dam crest).

#### **Assumption:**

- No bridge across the existing spillway will be provided

#### **Task 3.5 - Electrical Design**

The electrical design, if required, for the reservoir rehabilitation will be conducted in accordance with the following:

- NEC (National Electrical Code) 2014 will be the code basis for electrical design
- It is currently assumed that the existing PNM (Public Service Company of NM) electric service will be able to accommodate the additional electrical loads. Final confirmation of the added electrical loads will be completed during the design phases as the electrical loads are defined in more detail
- The primary power source for the new intake tower is expected to be from the existing pump station
- New electrical equipment required will follow any City preferred supplier list(s) or we will attempt to match existing equipment manufacturers. Any sole-source procurement restrictions defined by City procurement will be followed
- The existing facility is supported from an existing single standby diesel generator set. No additional generation is expected to be supplied as part of the rehabilitation. This is contingent on the new electrical loads being supported by the existing electrical service
- If power is lost and the existing facility has a protocol for load shedding to match the size of the existing single standby diesel generator set the new and existing electrical actuators should be included in the load to be retained. All new gate actuators shall be equipped with a hand wheel for manual operation
- The electric distribution system utilization power will be 480V 3 phase power with 120V convenience receptacle service to the new intake tower. The delivery power will be in above and underground conduit with power conductors between the existing electrical distribution and the intake tower
- New Mexico has a state Dark Sky Protection ordinance. The design of site safety lighting will comply with this act, while also satisfying OSHA work area illumination requirements. In general, it is expected the lighting design will include full cut-off luminaires, with automatic and manual controls. LED fixtures will be preferred due to very low maintenance and high efficiency. [http://www.delapp.com/codes/nm\\_night\\_sky\\_protection\\_act\\_nmsa74-12-1.php](http://www.delapp.com/codes/nm_night_sky_protection_act_nmsa74-12-1.php)
- No loud noise is expected from any of the electrical gear added in this Project

- No additional air emission permitting is expected, as the existing electrical service is already supported by a standby diesel generator set

### **Task 3.6 - Development of Design Drawings**

URS will provide final design services based on the preferred alternative as documented in the PER. It is envisioned that there will be design drawing submittals at 30%, 60%, 90% and final design stages. To the extent practical, the reservoir enlargement design drawings will be used and revised for the rehabilitation design.

#### **Assumption:**

- It is anticipated that the rehabilitation design can be documented by no more than 90 drawings. A change order will be required for additional drawings

### **Task 3.7 - Development of Technical Specifications**

URS will provide final technical specifications. The technical specifications will include Divisions 1 through 16. To the extent practical, the reservoir enlargement specifications will be used and revised for the rehabilitation design.

### **Task 3.8 - Design Report**

URS will prepare a Design Report that will describe the rehabilitation, the basis for design, the analysis completed and the design. A construction cost estimate and schedule will be included in the design report.

### **Task 3.9 - Cost Estimate and Schedule**

URS will perform the following for the revised design:

- Prepare an Engineer's Opinion of Probable Construction Cost
- Prepare a Construction Schedule

### **Task 3.10 - City and OSE Submittal and Approval**

URS will prepare the final design submittal for the City and OSE. We will develop the submittal in general accordance with OSE Rules. We will first submit the final design to the City for their initial review and then address their comments before submitting the report to the OSE for their review and approval. URS will stay in contact with the OSE during their review and will address their comments in a timely manner.

#### **Deliverables:**

The deliverables are as follows:

- Technical memorandum to summarize the design criteria to be used for the rehabilitation
- 30%, 60%, 90% and Final design packages consisting of the following:
  - Design Report (Table of contents only for 30% design deliverable)
  - Drawings
  - Specifications (Table of contents only for 30% design deliverable)
  - Construction Cost Estimate



**Assumptions:**

- Four meetings (one for each deliverable) will be held to communicate and discuss the design. These meetings will be held at the City offices in Las Vegas. Up to four URS employees will attend each meeting

**Task 4 – Construction Phase Services****Task 4.1 - Bidding**

Construction phase services will be completed to meet or exceed requirements of 19.25.12 NMAC that are applicable to construction permitting and construction activities. URS will support the City related to the project's bidding process. URS will hold a pre-bid conference with the potential bidders at the site to discuss the project elements. The bidding process will include answering contractor questions through written correspondence, issuance of clarifications and addenda, review of submitted bids for reasonableness, making a contractor selection recommendation, obtaining required documents from the selected contractor, and given notice to proceed for construction. URS will issue meeting minutes for the pre-bid meeting to the City and bidders.

**Task 4.2 - Evaluate Contractor's Submittals**

URS will review shop drawings, product data, samples and other submittals, and coordinate them with information contained in related documents. The submittals for materials and equipment (whether fabricated off-site or on-site) will be reviewed for general conformance that with the intent of the Contract Documents. URS will receive and review as required by the Contract Documents construction records, maintenance and operation instructions, schedules, certificates of compliance, and certificates of inspections.

**Task 4.4 - Conduct Meetings with Contractor**

Weekly review meetings will be held to review and coordinate construction services to meet the needs of the City.

**Task 4.5 - Coordinate Required Testing**

Field and laboratory testing for soil and concrete will be coordinated during construction to document the conditions of the work performed. Materials testing will be provided by the selected Contractor. URS will coordinate their activities in the field.

**Task 4.6 - Construction Observation**

URS will act as the initial interpreter of the requirements of the contract documents and judge of the acceptability of the work and make decisions on claims of Contractor relating to the acceptability of the work or the interpretation of the requirements of the Contract Documents pertaining to the execution and progress of the work. URS will serve as the initial interpreter of the Contract Documents and will notify the City of conditions, procedures, work quality, or schedule, as the Contractor affects them and will adversely affect the goals of the project.

**Task 4.7 - Maintain Project Files and Log Books**

URS will maintain files for correspondence, reports of job conferences, shop drawings, samples, submissions, and reproductions of original contract documents including all addenda, change orders, field orders, additional drawings issued subsequent to the execution of the contract, the engineer's clarifications and interpretations of the Contract Documents, progress reports, and other project related documents.

**Task 4.8 - Site Visit Logs**

URS will maintain a log book, recording dates and hours on the job site, weather conditions, data relative to questions of extras or deductions, list of visiting officials and representatives of manufacturers,

fabricators, suppliers and distributors, activities, decision, observations in general and record detailed results and procedures of tests conducted.

#### **Task 4.9 - Review and Recommend Construction Payments**

Based on URS' inspections and review of applications for payment and other accompanying data and schedules, determine the amounts owing to Contractor and recommend in writing payments to the Contractor in such amounts. Within ten days of receipt of an application for payment a recommendation will be for payment by the City or the application will be returned to the Contractor indicating in writing the reasons for refusing to recommend payment. If requested, URS will coordinate with the OSE to process payments.

#### **Task 4.10 - Conduct Final Inspections**

URS will conduct an inspection to determine if the project is substantially complete and a final inspection to determine if the work has been completed in general accordance with the Contract Documents. URS will also conduct an inspection to determine if the Contractor has fulfilled their obligations so that URS may recommend, in writing, final payment to Contractor and may give written notice to the City and the Contractor that the work is acceptable. URS, with the City's assistance, will determine if the project is "substantially complete" and specify the conditions under which URS should recommend final payment.

#### **Task 4.11 - Closeout Documents**

URS will prepare the required documents that will meet the OSE rules related to closeout documents. The closeout documents will include at a minimum that described in the following subsections.

##### **Revise Existing EAP**

The existing EAP will be revised to reflect the rehabilitation design.

Revised hydrologic/hydraulic analyses and inundation maps will be developed based on the rehabilitation design. The recently revised PMF hydrology will be utilized. Dam break flood routings during the Sunny Day breach, PMF with breach, and the maximum spillway release without a dam failure will be developed. A suitable computer program will be used to model formation of the dam breach and the resulting outflow hydrographs for all three floods. Existing inundation maps, if available, will be revised to reflect the new flood routings. The revised inundation maps will include, at critical downstream channel cross-sections (at structures including critical bridges, road crossings, occupied buildings, etc.), flood wave arrival times, time to peak, peak flow, and peak flow depth. The revised inundation maps will be developed using GIS mapping tool ESRI ArcMap. The revised inundation maps will be extended downstream to at least the same location as the existing inundation maps or a location where the flood no longer poses a threat to life or property. The analyses required to support the preparation of the revised inundation maps will be documented in a revised Breach Analysis Report.

The existing EAP document will be reviewed and revised, based on the rehabilitation design. The revised EAP will satisfy pertinent requirements of the OSE Rules, including 19.25.12 NMAC. Contacts on the notification flowcharts will be contacted and the flowcharts will be revised as required. The contacts listed for locally available materials, equipment, and manpower will also be contacted and revised as required. As discussed above, the inundation maps will be revised and included in the revised EAP. Based on OSE Rules, evacuation maps are required to be included in the EAP. The existing evacuation maps will be revised as required.

##### **Revise Existing O&M Manual**

The existing O&M Manual will be revised to reflect the rehabilitation design. The revised O&M Manual will satisfy pertinent requirements of the OSE Rules, including 19.25.12 NMAC. Record drawings from the rehabilitation design will be used to revise this document. The rating curves for the spillway and outlet works will be revised based on the rehabilitated configurations.

## Commission and Startup

### First Fill Plan

This task includes the preparation of a First Fill Plan and reviewing data collected during the first filling. A First Fill Plan is used to monitor the controlled rate of filling a reservoir after the construction of a new dam or after the construction of major modifications to an existing dam. The OSE Rules (19.25.12.17.B) require first fill criteria and monitoring requirements to be incorporated into the O&M Manual. We will discuss with the OSE if the First Fill Plan can be submitted as a stand-alone document to enable the reservoir to be filled prior to OSE acceptance of the O&M Manual. The First Fill Plan will include inspection checklists, instrumentation forms, recommendations for reservoir hold elevations and hold durations, inspection and instrumentation monitoring frequencies, reporting protocols, and emergency response information.

### Assumptions:

- A maximum of three inundation limits (Sunny Day failure, PMF with dam breach, and maximum flow through the spillways without a dam breach) will be shown on the inundation maps.
- An electronic version of the current version of the EAP will be provided to URS in Microsoft Word.
- That the existing EAP and inundation mapping is available in GIS format.
- An electronic version of the current version of the O&M Manual will be provided to URS from the NMDGF or the USFWS in Microsoft Word.
- The City will provide an employee to monitor the dam during first filling and that URS will not provide an inspector for this purpose.
- The first fill data will be reviewed and submitted to the OSE by URS for a maximum of 12 months, which includes a maximum of 12 transmittal memorandums.
- It is assumed that surveying of the movement points will be performed during first filling. This proposal does not include these surveying costs.
- 13 month construction duration and 13 months on site by Staff 4 engineer
- One site visit per month over 13 months by Project 4 engineer
- One contractor payment to be assessed per month over 13 months
- Weekly meetings with the contractor to take place over the phone with Project 4 engineer and on site engineer
- Close out drawings based on construction drawings with notations where as constructed differs from designed
- Allowance for WHP to be used for closeout drawings for as constructed drawings
- Fee estimate based on an assumed level of effort. Additional effort beyond that envisioned would likely incur a change order
- Fee estimate includes the supervision of the initial filling of the reservoir in accordance with OSE Rules. It is assumed that the initial filling of the reservoir will be done within the 13 month construction duration

### Schedule

The above scope of work will be completed as presented on the attached schedule.

**Budget**

The above scope of work will be performed based on a time and materials not to exceed amount of \$1,779,850 which includes 7.1875% for New Mexico Gross Receipt tax. The attached spreadsheet presents the details of the proposed budget.

IN WITNESS THEREOF, the parties hereto have executed, or caused to be executed, by their duly authorized officials, this Amendment in triplicate on the respective dates indicated below.

ATTEST: \_\_\_\_\_

Type Name \_\_\_\_\_

Title \_\_\_\_\_

Date \_\_\_\_\_

OWNER: City of Las Vegas

By \_\_\_\_\_

Type Name \_\_\_\_\_

Title \_\_\_\_\_

Date \_\_\_\_\_

FUNDING AGENCY REVIEW  
NM OFFICE OF THE STATE  
ENGINEER

*Charles N. Thompson*  
CHARLES N. THOMPSON

1/2/17

ENGINEER: URS Corporation

By *Ed A. Toms* \_\_\_\_\_

Type Name Ed A. Toms

Title Vice President

Address 6200 South Quebec Street

Greenwood Village, Colorado 80111

Date January 1, 2017

**Bradner Dam Rehab Project - Fee Summary**

<b>Fee Estimate with Full Time Construction Phase Services</b>	
<b>Project Management (8%)</b>	<b>\$ 121,630</b>
<b>Environmental Permitting</b>	<b>\$ 68,220</b>
<b>Rehabilitation Design</b>	<b>\$ 705,050</b>
<b>Construction Phase Services - Full Time</b>	<b>\$ 747,104</b>
<b>Total</b>	<b>\$ 1,642,000</b>
<b>Total (Including GRT)</b>	<b>\$ 1,760,020</b>

GRT (%)

7.1875%

**Environmental Permitting  
Budget Estimate**

Environmental Permitting

<b>Labor</b>	<b>Total Hours</b>	<b>Rate</b>	<b>Unit</b>	<b>Hours</b>	<b>Grand Total</b>
Assistant/Support Staff 1	0	\$47	\$/hr		\$0
Assistant/Support Staff 2	0	\$58	\$/hr		\$0
Assistant/Support Staff 3	0	\$69	\$/hr		\$0
Assistant/Support Staff 4	0	\$79	\$/hr		\$0
Assistant/Support Staff 5 (Aileen Torres)	16	\$91	\$/hr	16	\$1,456
Assistant/Support Staff 6	0	\$101	\$/hr		\$0
Assistant/Support Staff 7 (Gordy Tucker)	8	\$111	\$/hr	8	\$888
Assistant/Support Staff 8	0	\$122	\$/hr		\$0
Assistant/Support Staff 9	0	\$133	\$/hr		\$0
Assistant/Support Staff 10	0	\$143	\$/hr		\$0
Staff 1	0	\$84	\$/hr		\$0
Staff 2 (Shrimpton/Sutherland)	124	\$96	\$/hr	124	\$11,904
Staff 3 (Rich Chamberlain)	32	\$106	\$/hr	32	\$3,392
Staff 4	0	\$116	\$/hr		\$0
Project 1	0	\$128	\$/hr		\$0
Project 2 (Kim Pirri)	80	\$138	\$/hr	80	\$11,040
Project 3 (Jeff Dawson)	60	\$148	\$/hr	60	\$8,880
Project 4	0	\$160	\$/hr		\$0
Consultant 1 (Andrea Parker)	100	\$175	\$/hr	100	\$17,500
Consultant 2 (Gene Rogge)	40	\$191	\$/hr	40	\$7,640
Consultant 3	0	\$207	\$/hr		\$0
Consultant 4	20	\$222	\$/hr	20	\$4,440
Principal 1	0	\$245	\$/hr		\$0
<b>Labor Subtotal</b>				<b>\$67,140</b>	<b>\$67,140</b>
<b>Communication Markup</b>		0%		<b>\$0</b>	<b>\$0</b>
<b>Labor Total</b>				<b>\$67,140</b>	<b>\$67,140</b>
<b>Other Direct Costs</b>	<b>No. Units</b>	<b>Rate</b>	<b>Unit</b>	<b>Number</b>	<b>Grand Total</b>
Airfare	2	\$400	Round Trip	1	\$400
Rental Vehicles	1	\$80	Day	1	\$80
Lodging	2	\$110	Night	2	\$220
Meals	2	\$60	Day	2	\$120
Parking Fees	2	\$30	Day	2	\$60
Field Supplies (GPS, Data request, postage)	0	\$20	Each	0	\$0
Miscellaneous (document production/FedEx)	1	\$200	Each	1	\$200
Long Term Truck Rental	0	\$1,500	Month		\$0
Long Term Lodging	0	\$1,700	Month		\$0
<b>Other Direct Costs Subtotal</b>				<b>\$1,080</b>	<b>\$1,080</b>
<b>Other Direct Costs Markup</b>		0%		<b>\$0</b>	<b>\$0</b>
Mileage	20	0.58	Miles		
<b>Milage Subtotal</b>				<b>\$0</b>	<b>\$0</b>
<b>Other Direct Costs Total</b>				<b>\$1,080</b>	<b>\$1,080</b>
<b>Subcontracts</b>		<b>Rate</b>	<b>Unit</b>	<b>Cost</b>	<b>Grand Total</b>
					\$0
<b>Subcontracts Subtotal</b>				<b>\$0</b>	<b>\$0</b>
<b>Subcontracts Markup</b>		5%		<b>\$0</b>	<b>\$0</b>
<b>Subcontracts Total</b>				<b>\$0</b>	<b>\$0</b>
<b>GRAND TOTAL</b>				<b>\$68,220</b>	<b>\$68,220</b>

Rehabilitation Design  
Budget Estimate

Labor	Total Hours	Rate	Unit	Hours											Grand Total	
				Instrument and Mechanical Design	Hydraulic Design	General Civil Design	Electrical Design	Structural Design	Design Drawings	Permitting	Design Support	Cost Estimating and Schedule	Markup for 20% O&M, 40% and 75% Subcontract			
Assistant/Support Staff 1	0	\$47	\$/hr													
Assistant/Support Staff 2	0	\$58	\$/hr													
Assistant/Support Staff 3	0	\$69	\$/hr													
Assistant/Support Staff 4	0	\$79	\$/hr													
Assistant/Support Staff 5	0	\$91	\$/hr													
Assistant/Support Staff 6	90	\$191	\$/hr								20	20	20			\$6,860
Assistant/Support Staff 7	1000	\$111	\$/hr							1000						\$111,000
Assistant/Support Staff 8	1000	\$122	\$/hr							1000						\$122,000
Assistant/Support Staff 9	0	\$133	\$/hr													\$0
Assistant/Support Staff 10	0	\$143	\$/hr													\$0
Staff 1	0	\$34	\$/hr													\$0
Staff 2	1080	\$96	\$/hr	280	160	80	20	160	260	20	80	20				\$103,680
Staff 3	0	\$106	\$/hr													\$0
Staff 4	0	\$116	\$/hr													\$0
Project 1	0	\$128	\$/hr													\$0
Project 2	560	\$138	\$/hr	40	80	40	120	40				80	80	80		\$77,280
Project 3	980	\$148	\$/hr	120	160	60	40	180	280	40	80	40				\$145,040
Project 4	280	\$160	\$/hr	40	40	20	20	40	40	20	40	20				\$44,800
Consultant 1	0	\$175	\$/hr													\$0
Consultant 2	0	\$191	\$/hr													\$0
Consultant 3	0	\$207	\$/hr													\$0
Consultant 4	300	\$222	\$/hr	20	20	20	20	20	60	20	20	20		80		\$66,600
Principal 1	0	\$245	\$/hr													\$0
Labor Subtotal				\$61,000	\$68,920	\$19,720	\$31,040	\$58,160	\$316,160	\$17,500	\$43,420	\$18,540		\$18,800		\$876,460
Communication Markup		0%		\$0	\$0	\$0	\$0	\$0	\$0	\$0	\$0	\$0		\$0		\$0
Labor Total				\$61,000	\$68,920	\$19,720	\$31,040	\$58,160	\$316,160	\$17,500	\$43,420	\$18,540		\$18,800		\$876,460
Other Direct Costs	No. Units	Rate	Unit	Number											Grand Total	
Airfare	2	\$400	Round Trip													\$0
Rental Vehicles	15	\$80	Day			3								12		\$1,200
Lodging	2	\$110	Night			2								2		\$220
Meals	33	\$60	Day			3								32		\$1,980
Parking Fees	2	\$30	Day													\$60
Field Supplies (GPS, Data request, postage)	0	\$20	Each													\$0
Miscellaneous (document production/PDF/xr)	1	\$200	Each											1		\$200
Long Term Truck Rental	0	\$1,500	Month													\$0
Long Term Lodging	0	\$1,700	Month													\$0
Other Direct Costs Subtotal				\$0	\$0	\$440	\$0	\$0	\$0	\$0	\$0	\$0	\$0	\$0	\$0	\$8,640
Other Direct Costs Markup		0%		\$0	\$0	\$0	\$0	\$0	\$0	\$0	\$0	\$0		\$0		\$0
Mileage	30	0.58	Miles													\$17.40
Mileage Subtotal				\$0	\$0	\$0	\$0	\$0	\$0	\$0	\$0	\$0		\$0		\$0
Other Direct Costs Total				\$0	\$0	\$440	\$0	\$0	\$0	\$0	\$0	\$0		\$0		\$8,640
Subcontracts	Rate	Unit		Cost											Grand Total	
Geomchanics - Drilling	\$6,000															
WH Pacific, Inc. - Survey	\$3,000															
New Image Construction	\$10,000															
Vision Imposition Contractor	\$10,000															
Subcontracts Subtotal				\$19,000	\$0	\$0	\$0	\$0	\$0	\$0	\$0	\$0		\$0		\$19,000
Subcontracts Markup	5%			\$950	\$0	\$0	\$0	\$0	\$0	\$0	\$0	\$0		\$0		\$950
Subcontracts Total				\$19,950	\$0	\$0	\$0	\$0	\$0	\$0	\$0	\$0		\$0		\$19,950
GRAND TOTAL				\$80,950	\$69,920	\$20,160	\$31,040	\$58,160	\$316,160	\$17,500	\$43,420	\$18,540		\$18,800		\$1,001,250

**Construction Phase Services - Full Time Budget Estimate**

Labor	Total Hours	Rate	Unit	Building	Purchase Contractor's Submittals	Conduct Meetings with Contractor	Oversees Required Training	Site Visit, Judge Appropriability of Methods, Project Plan and Log Books	Schedule and Management Construction Payments	Conduct Final Inspections	Review MAP	Review O&M Manual	Closeout Documents	Mobilize Resource Billing	Grand Total	
																Hours
Assistant/Support Staff 1	0	\$47	S/hr												50	
Assistant/Support Staff 2	0	\$58	S/hr												50	
Assistant/Support Staff 3	0	\$59	S/hr												50	
Assistant/Support Staff 4	0	\$79	S/hr												50	
Assistant/Support Staff 5	0	\$91	S/hr												50	
Assistant/Support Staff 6	0	\$101	S/hr												50	
Assistant/Support Staff 7	272	\$111	S/hr	16	16	16	16	40	40	16	16	16	40	40	536,192	
Assistant/Support Staff 8	0	\$122	S/hr												50	
Assistant/Support Staff 9	0	\$133	S/hr												50	
Assistant/Support Staff 10	0	\$143	S/hr												50	
Staff 1	0	\$84	S/hr												50	
Staff 2	312	\$96	S/hr	16	16	16	16	16	16	16	80	40	40	40	519,952	
Staff 3	0	\$106	S/hr												50	
Staff 4	3320	\$116	S/hr	80				3000			60	20	80	80	5385,120	
Project 1	0	\$128	S/hr												50	
Project 2	0	\$138	S/hr												50	
Project 3	1648	\$148	S/hr	80	80	52	52	312	52	80	80	20	120	120	5165,104	
Project 4	0	\$160	S/hr												50	
Consultant 1	0	\$173	S/hr												50	
Consultant 2	0	\$191	S/hr												50	
Consultant 3	0	\$207	S/hr												50	
Consultant 4	318	\$222	S/hr	16	16	16	16	80	16	16	16	16	40	40	563,936	
Principal 1	0	\$245	S/hr												50	
<b>Labor Subtotal</b>				<b>337,084</b>	<b>318,704</b>	<b>516,600</b>	<b>516,600</b>	<b>3417,032</b>	<b>317,324</b>	<b>318,704</b>	<b>331,800</b>	<b>314,448</b>	<b>344,300</b>	<b>344,300</b>	<b>3864,304</b>	
<b>Construction Markup</b>		0%		<b>33</b>	<b>33</b>	<b>33</b>	<b>33</b>	<b>33</b>	<b>33</b>	<b>33</b>	<b>33</b>	<b>33</b>	<b>33</b>	<b>33</b>	<b>33</b>	
<b>Labor Total</b>				<b>337,084</b>	<b>318,704</b>	<b>516,600</b>	<b>516,600</b>	<b>3417,032</b>	<b>317,324</b>	<b>318,704</b>	<b>331,800</b>	<b>314,448</b>	<b>344,300</b>	<b>344,300</b>	<b>3864,304</b>	
<b>Other Direct Costs</b>	<b>No. Units</b>	<b>Rate</b>	<b>Unit</b>	<b>Number</b>												<b>Grand Total</b>
Office	7	\$400	Month/Title												28	
Rental Vehicle	6	\$80	Day	3							3				\$480	
Lodging	2	\$110	Night	2							4				\$660	
Meals	466	\$60	Day	3				459			4				\$27,960	
Parking Fees	2	\$30	Day												\$60	
Field Supplies (GPS, Data equipment, postage)	0	\$25	Each												\$0	
Miscellaneous (equipment production/Fuel/Ex)	1	\$200	Each	2							2	2	2		\$1,600	
Long Term Truck Rental	13	\$1,500	Month					13							\$19,500	
Lease Term Linchpins	13	\$1,700	Month					13							\$22,100	
<b>Other Direct Costs Subtotal</b>				<b>11,000</b>	<b>50</b>	<b>50</b>	<b>50</b>	<b>\$69,140</b>	<b>30</b>	<b>\$938</b>	<b>\$400</b>	<b>\$400</b>	<b>\$400</b>	<b>\$0</b>	<b>\$73,390</b>	
<b>Other Direct Costs Markup</b>		0%		<b>30</b>	<b>30</b>	<b>30</b>	<b>30</b>	<b>30</b>	<b>30</b>	<b>30</b>	<b>30</b>	<b>30</b>	<b>30</b>	<b>30</b>	<b>30</b>	
<b>Other Direct Costs Total</b>				<b>11,030</b>	<b>80</b>	<b>80</b>	<b>80</b>	<b>\$69,140</b>	<b>60</b>	<b>\$938</b>	<b>\$400</b>	<b>\$400</b>	<b>\$400</b>	<b>\$0</b>	<b>\$73,390</b>	
<b>Subcontractors</b>	<b>Rate</b>	<b>Unit</b>	<b>Cost</b>												<b>Grand Total</b>	
W/P/Prof. Ins. - Service															\$10,000	
Subcontractors Subtotal				<b>20</b>	<b>20</b>	<b>20</b>	<b>20</b>	<b>20</b>	<b>20</b>	<b>20</b>	<b>20</b>	<b>20</b>	<b>20</b>	<b>20</b>	<b>\$10,000</b>	
Subcontractors Markup		5%		<b>10</b>	<b>10</b>	<b>10</b>	<b>10</b>	<b>10</b>	<b>10</b>	<b>10</b>	<b>10</b>	<b>10</b>	<b>10</b>	<b>10</b>	<b>\$500</b>	
<b>Subcontractors Total</b>				<b>30</b>	<b>30</b>	<b>30</b>	<b>30</b>	<b>30</b>	<b>30</b>	<b>30</b>	<b>30</b>	<b>30</b>	<b>30</b>	<b>30</b>	<b>\$10,500</b>	
<b>GRAND TOTAL</b>				<b>339,014</b>	<b>318,704</b>	<b>516,600</b>	<b>516,600</b>	<b>3487,032</b>	<b>317,324</b>	<b>319,634</b>	<b>331,800</b>	<b>314,448</b>	<b>355,100</b>	<b>344,300</b>	<b>3747,104</b>	



**Work Session**

**CITY COUNCIL MEETING AGENDA REQUEST**

**DATE:** 12/30/16

**DEPT:** Utilities Dept.

**MEETING DATE:** 01/11/17

**DISCUSSION ITEM/TOPIC:** Purchase of a 5 yard dump truck.

**BACKGROUND/RATIONALE:** The Gas Division seeks to purchase a 5 yard dump truck. The current dump truck is over 15 years old and has lost power which is causing problems when trying to haul trailers loaded with equipment.

The new truck will be a Ford F750 diesel powered vehicle and will assist the Gas divisions with placing and removing gravel, base course etc. as well as hauling the hydro excavator and the directional drill to job sites. It will allow the division to continue to provide quality service to the customers and the community.

The cost to purchase the dump truck is \$76,027. The cost to lease the truck would range from \$109,404 to \$115,134 depending on the term of the lease. The warranty period will be from 24 to 60 months based on the part.

This item has been budgeted for and will be paid out of line item 627-0000-650-8007.

**THIS REQUEST FORM MUST BE SUBMITTED TO THE CITY CLERK'S OFFICE NO LATER THAN 5:00 P.M. ON FRIDAY ONE AND A HALF WEEKS PRIOR TO THE CITY COUNCIL MEETING.**

  
SUBMITTER'S SIGNATURE

**REVIEWED AND APPROVED BY:**

  
TONITA GURULÉ-GIRÓN  
MAYOR

  
RICHARD TRUJILLO  
CITY MANAGER

\_\_\_\_\_  
ANN MARIE GALLEGOS  
FINANCE DIRECTOR  
(PROCUREMENT)

\_\_\_\_\_  
PURCHASING AGENT  
(FOR BID/RFP AWARD)

\_\_\_\_\_  
H. CHICO GALLEGOS  
CITY ATTORNEY  
(ALL CONTRACTS MUST BE  
REVIEWED)



# CITY OF LAS VEGAS

1700 N. GRAND AVE. • LAS VEGAS, NEW MEXICO 87701-4731 • 505-454-1401 • FAX: 505-425-7335

**TONITA GURULÉ-GIRÓN**  
**Mayor**

## MEMORANDUM

TO: Maria Gilvarry, Utilities Director

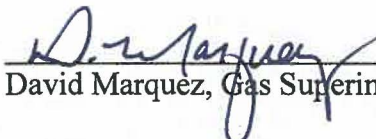
FROM:   
David Marquez, Gas Superintendent

DATE: December 16, 2016

RE: Purchase of 5 Yard Dump Truck

---

The Gas Division is requesting to purchase a new 5 yard dump truck. We currently own a 2000 GMC dump truck which is a regular unleaded fueled truck that has lost power over the years. As a result, it is struggling to dump and pull trailers loaded with equipment.

The division recently purchased a hydro excavator and a JT20 directional drill; and this new dump truck would be ideal for pulling this equipment. The new truck would also assist with placing and removing gravel, base course, etc. and with our day to day duties and maintenance.

The new dump truck we are looking to purchase is a Ford F750 with a diesel powered engine. This new truck will allow us to continue to provide quality service to our customers. Your consideration is greatly appreciated.

Feel free to contact me with any questions. Thank you.

XC: File



leasing 2

Lessee  
Las Vegas, NM

Vendor  
Summit Truck Group

<b>Proposal Date:</b>	December 1, 2016				
<b>Equipment Description:</b>	1- International Model 7400 Dump Truck				
<b>Commencement Date:</b>	December 15, 2016				
	<u>Option 1</u>	<u>Option 2</u>	<u>Option 3</u>	<u>Option 4</u>	<u>Option 5</u>
<b>Equipment Cost:</b>	\$99,576	\$99,576	\$99,576	\$99,576	\$99,576
<b>Lessee Down Payment:</b>					
<b>Amount Financed:</b>	\$99,576	\$99,576	\$99,576	\$99,576	\$99,576
<b>Lease Term:</b>	4 Years	5 Years	6 Years	3 Years	4 Years
<b>First Payment Date:</b>	5/15/2017	5/15/2017	5/15/2017	5/15/2017	5/15/2017
<b>Payment Frequency:</b>	Annual	Annual	Annual	Quarterly	Quarterly
<b>Lease Rate:</b>	5.09%	5.18%	5.22%	5.09%	5.09%
<b>Payment Amount:</b>	\$27,351.10	\$22,451.63	\$19,189.06	\$9,079.18	\$6,978.56
<b>Payment Factor:</b>	0.27468	0.22547	0.19271	0.09118	0.07008

**Qualifications:**

- Pricing:** This is a lease proposal for the payment stream(s) indicated above. If any of the information identified above are not correct, please advise us so that we can determine if a new proposal is required. Other important elements of this proposal are:
  - Rate Expiration:** Signing this proposal does not in itself lock in your rate. This lease must be credit approved, contracts properly signed, and the lease funded by Leasing 2 within thirty days from the date of this proposal to protect the rates quoted.
  - Closing Costs:** There will be no up-front costs of any kind charged by Lessor including closing costs, points, administrative costs, etc. Your attorney may charge you to review the lease documents and complete the opinion letter required with our lease documentation.
  - Closing Costs:** There will be a N/A document fee due at closing.
- Type of Lease:** This is a lease-purchase type of financing. After all the lease payments are made, Lessee will own the equipment without further cost.
- Financial Reporting:** All city, county and tax districts (including fire districts) will be expected to provide GAAP audited financial reports. All non-profit corporations (vfd's) will be expected to provide IRS 990 federal tax returns. If you do not maintain these types of financial reports, please contact us to discuss.
- Vendor Payable / Escrow Account (where applicable):** In the event that the truck(s) and/or equipment are not ready to be delivered, proceeds of this lease will be held in a vendor payable account until delivery/acceptance. This is a non-interest bearing account to Lessee.
- Credit Approval and Documentation:** This is a proposal only, and does not represent a commitment to lease. This financing is subject to credit review and approval and execution of mutually acceptable documentation, including the opinion of lessee's counsel opining that the agreement is legal, valid and binding, and qualified as a tax exempt obligation under the tax reform act of 1986 as amended.

Financing provided by: **Leasing 2, Inc.** Date: December 1, 2016  
 Email: rcarney@leasing2.com Contact: Rick Carney  
 Web: www.leasing2.com Phone: 800-287-5155 x16

**REQUEST TO PROCEED:** When you are ready to proceed towards finalizing this lease, please email/fax a signed and completed proposal as indicated below. We will immediately email you "next step" instructions.

Proposal date: December 1, 2016      Option Chosen: \_\_\_\_\_ (where applicable)  
 Last month of your budget year? \_\_\_\_\_

Las Vegas, NM  
 Name of Lessee

\_\_\_\_\_  
 Authorized Signature      \_\_\_\_\_  
 Date

\_\_\_\_\_  
 Contact E-Mail Address      \_\_\_\_\_  
 Contact Phone

Please complete the above information and fax or email all pages of the proposal to  
 813-258-9333 / rcarney@leasing2.com

# MUNICIPAL LEASING

## HOW IT CAN HELP YOU ACQUIRE MORE TRUCKS

---

THE BENEFITS OF MUNICIPAL LEASING ARE SIMPLE TO APPRECIATE:

- ▶ Competitive interest rates offer an alternative to bond financing
  - ▶ Low-cost, tax-exempt capital to maximize use of budgeted funds
  - ▶ Flexible repayment terms allow transaction to be structured to meet budgets; payment terms normally range from two to six years and can be monthly, quarterly or annual
  - ▶ Often, no down payment is required and 100% of equipment cost is financed
  - ▶ Simple and concise documentation speeds completion of transaction
  - ▶ No debt is created so voter approval is generally not required
  - ▶ Matches expense with useful product life
  - ▶ Protection against obsolescence
  - ▶ Easier to upgrade financed assets
  - ▶ Equity is built by using municipal leasing
  - ▶ Simple and quick
- 

**SUMMIT TRUCK GROUP /  
ROBERTS TRUCK CENTER**  
1623 Aspen Ave NW  
Albuquerque, NM 87104

**SUMMIT**  
TRUCK GROUP  
A HIGHER STANDARD OF VALUE



## Selected Options

Code	Description	MSRP
<b>Base Vehicle</b>		
F7D	Base Vehicle Price (F7D)	\$68,500.00
<b>Engines</b>		
99X	6.7L Power Stroke V8 Turbo Diesel - 330 HP @ 2600 RPM, 725 lb-ft Torque @ 1800 RPM	\$3,495.00
	Includes Engine Exhaust Brake and manual regen capability. Torque: 725 ft.lbs. @ 1800 rpm. <i>Governed RPM: 3400. Includes CARB clean idle label - may be removed if un-necessary.</i>	
425	50-State Emissions	N/C
41H	Engine Block Heater, Phillips, 120 Volt/750 Watt	\$60.00
<b>Transmissions</b>		
44G	Ford TorqShift HD 6-Speed Automatic - Double Overdrive, less PTO Provision	STD
41A	Transmission Power Take-Off Provision w/LiveDrive Capability	\$895.00
<b>Front Wheels &amp; Tires</b>		
647	Wheels, Front 22.5x7.5 White Powder Coated Steel, 10-Hole <i>(285.75MM BC) hub piloted, flanged nut, metric mount, 7.50 DC rims; with steel hubs.</i>	STD
TDG	Tires, Front Two 295/80R22.5H Continental HSR2 (501 rev/mile)	\$395.00
<b>Rear Wheels &amp; Tires</b>		
667	Wheels, Rear 22.5x7.5 White Powder Coated Steel, 10-Hole <i>(285.75MM BC) hub piloted, flanged nut, metric mount, 7.50 DC rims; with steel hubs.</i>	STD
RDG	Tires, Rear Four 295/80R22.5H Continental HSR2 (501 rev/mile)	\$395.00
<b>Brakes</b>		
67D	Air Brakes - Straight Truck w/Traction Control  <i>Meritor Q-Plus with ABS, Bendix Anti-Lock Brake System, 4-channel. Includes 15" x 4" front brakes, dual direct reading air pressure gauges, brake lines color coded nylon, Bendix 13.2 CFM capacity air compressor, instrument panel mounted yellow knob parking brake control valve, automatic slack adjusters front and rear, two rear spring parking air brake chambers mounted on front of rear axle, three drain valves and two air tanks (Reference Body Builders Book for location). Rear brake size and components dependent upon axle selection. Uses existing ABS system to minimize wheel slipping during acceleration. Usage determined by the air brake package selected. (Should NEVER be used with Hi-Rail Train Systems).</i>	\$2,075.00

Prices and content availability as shown are subject to change and should be treated as estimates only. Actual base vehicle, package and option pricing may vary from this estimate because of special local pricing, availability or pricing adjustments not reflected in the dealer's computer system. See salesperson for the most current information.



## Selected Options (cont'd)

Code	Description	MSRP
62D	Air Dryer, Bendix AD/IP w/Heater <i>Mounted left frame rail.</i>	\$460.00
158	Trailer Air Brake Package <i>Includes air lines to rear of frame, hand control valve and tractor protection valve.</i>	\$365.00
159	Trailer Connection Socket - 7-Way, Wired for Turn Signals Combined with Stop <i>Mounted at rear of frame, for combined trailer stop, tail, turn (compatible with trailers that use combined stop, tail, turn lights).</i>	\$100.00

### Front Axle and Suspension

43P	12,000 lb. Cap. Non-Driving - Dana E-1202I - I-Beam Type	\$525.00
61D	Taper-Leaf Springs, Parabolic - 12,000 lb. Cap <i>2-leaf. 62" x 3.15"</i>	\$305.00
15S	Front Stabilizer Bar	\$490.00
60A	Lube, Front Axle, EmGard 50W, Synthetic Oil	\$50.00

### Rear Axle and Suspension

47X	26,000 lb. Single Reduction - Open - Dana / Spicer S26-190 <i>NOTE: When specifying an axle ratio, check performance guidelines for startability and gradeability.</i>	\$2,445.00
52P	Driveshaft Upgrade	\$185.00
68T	Multi-Leaf Springs - 31,000 lb. Cap <i>11-leaf. Includes 2,000 lb auxiliary springs for load stabilization.</i>	\$490.00
961	Shock Absorbers, Rear - Double Acting	\$165.00
607	Lube, Rear Axle, EmGard 75W-90, Synthetic Oil	\$100.00
X6E	6.83 Axle Ratio	N/C

### Wheelbase

158WB	158" Wheelbase/84" CA/49" AF/246" OAL	STD
-------	--	-----

### Frame

539	Single Channel - Straight 'C' 20.11 SM, 120,000 PSI <i>2,413,200 RBM. Heat treated alloy steel: 10.375" x 3.705" x 0.438" (263.5mm x 94.1mm x 11.1mm).</i>	\$1,075.00
-----	--	------------

Prices and content availability as shown are subject to change and should be treated as estimates only. Actual base vehicle, package and option pricing may vary from this estimate because of special local pricing, availability or pricing adjustments not reflected in the dealer's computer system. See salesperson for the most current information.



## Selected Options (cont'd)

Code	Description	MSRP
<b>Exhaust</b>		
91G	Under Cab, Right Side Outlet, Switchback-Style <i>Single, horizontal muffler, right side, under cab, outside of frame rail with rear discharge.</i>	STD
<b>Fuel Tanks</b>		
65E	Fuel Tank - LH 65 Gallon Rectangular - Aluminum	\$425.00
12	12 Gal. Single Tank Fuel Fill. Mandatory Charge Applied, Based On Tank Selection	\$0.00
<b>Electrical / Alternator / Battery</b>		
17A	200 Amp Denso SC5 Heavy Duty Alternator <i>Extra heavy duty 12 Volt.</i>	Included
55M	Jump Start Stud - Remote Mounted	\$90.00
63B	Battery - Two 900 CCA, 1800 Total, Includes Steel Battery Box <i>12Volt, Motorcraft.</i>	\$60.00
17M	Back-Up Alarm - Electric, 102 dBA	\$110.00
<b>Seats</b>		
88N	30/0/30 Air Ride Driver (External Air Source) & Fixed Passenger w/Console - Vinyl	\$395.00
<b>Cab Interior</b>		
600A	Preferred Equipment Package 600A <i>Includes: - Bumper, Front - Black, Full Width - Wheel Seals, Front - Oil Lubricated, SKF ScotSeal PlusXL Seals - Wheel Seals, Rear - Oil Lubricated, SKF ScotSeal PlusXL Seals - Manual Regen Initiation - Driver Interface in Message Center - Engine Exhaust Brake - 200 Amp Denso SC5 Heavy Duty Alternator - Extra heavy duty 12 Volt. - Painted Grille - Plastic - Lights - Roof Marker/Clearance - Amber Lenses, 5 Lights - Tow Hooks, Front (2) - Frame-Mounted, Painted Black - Four Body Builder Switches - Mounted in Center Instrument Panel - With connector access located in engine compartment. Amperages vary by switch: 10, 15, 25, 25. - Floor Covering - Black Vinyl - Intelligent Oil Life Monitor - Steering Column - Tilt - Steering Wheel - Black PVC w/Integral Cruise Control Switches - Body Builder Wiring - At Back of Cab, Combined Includes sealed connectors for 2 ground circuits, with combined left/stop, combined right/stop, park lamps, back up lamps. Also includes 2 additional pass through wires to cab.</i>	N/C
55P	110 A/C Outlet - in Lower Center Finish Panel	\$100.00

Prices and content availability as shown are subject to change and should be treated as estimates only. Actual base vehicle, package and option pricing may vary from this estimate because of special local pricing, availability or pricing adjustments not reflected in the dealer's computer system. See salesperson for the most current information.



Don Chalmers Ford  
 2500 Rio Rancho Blvd, S.E., Rio Rancho, New  
 Mexico, 871241095  
 Office: 505-897-2500

2017 F-750 Diesel, Regular Cab  
 Regular Cab Base(F7D)

## Selected Options (cont'd)

Code	Description	MSRP
21D	SYNC Media System <i>Includes dash mounted USB 2.0 port and redundant steering wheel SYNC controls.</i>	\$395.00
586	Radio, Electronic Premium AM/FM Stereo, Disc <i>With 4 speakers, dash-mounted aux audio input jack and clock and redundant steering wheel audio controls.</i>	\$280.00
<b>Cab Exterior</b>		
54C	Mirrors, Dual - Heated Rectangular, XL2020 - 102" Width <i>Integral spot mirror, sail type, manual fold, solid black finish.</i>	\$90.00
165	Mud Flap Holder Without Flaps	\$95.00
<b>Miscellaneous</b>		
PAINT	Paint Type - Environmentally Friendly, "3 - Wet System"	STD
<b>Fleet Options</b>		
B4A	Net Invoice Fleet Option	\$0.00
<b>Interior Colors</b>		
E_01	Gray	N/C
<b>Primary Colors</b>		
YZ_01	Oxford White	N/C
SUBTOTAL		\$84,610.00
Destination Charge		\$1,495.00
TOTAL		\$86,105.00

Prices and content availability as shown are subject to change and should be treated as estimates only. Actual base vehicle, package and option pricing may vary from this estimate because of special local pricing, availability or pricing adjustments not reflected in the dealer's computer system. See salesperson for the most current information.

Prepared for: DAVID MARQUEZ, Superintendent, City of Las Vegas Utilities Dept  
 By: Darrel Clement Date: 11/28/2016 | Price Level: 745 Quote ID: 112816





Don Chalmers Ford  
 2500 Rio Rancho Blvd, S.E., Rio Rancho, New Mexico, 871241095  
 Office: 505-897-2500

**2017 F-750 Diesel, Regular Cab**  
**Regular Cab Base(F7D)**

## Pricing - Single Vehicle

	<b>MSRP</b>
<i>Vehicle Pricing</i>	\$86,105.00
<i>Pre-Tax Adjustments</i>	
<b>Code</b>	<b>Description</b>
CES17MD	CES 2017 Medium Duty contract discount
	-\$10,078.00
<small>CES 2017 MY Medium Duty chassis discount. 12% before destination. National Fleet Incentive plus upfit</small>	
<b>Subtotal</b>	<b>\$76,027.00</b>
<i>Discount Adjustments</i>	\$0.00
<b>Total</b>	<b>\$76,027.00</b>

Customer Signature

Acceptance Date

Prices and content availability as shown are subject to change and should be treated as estimates only. Actual base vehicle, package and option pricing may vary from this estimate because of special local pricing, availability or pricing adjustments not reflected in the dealer's computer system. See salesperson for the most current information.

Prepared for: DAVID MARQUEZ, Superintendent, City of Las Vegas Utilities Dept  
 By: Darrel Clement Date: 11/28/2016 | Price Level: 745 Quote ID: 112816



## Performance

Performance predictions in this report represent an estimate of vehicle performance based on standard operating conditions. Variations in customer equipment, load configuration, ambient conditions, and/or operator driving techniques can cause significant variations in vehicle performance. These values are not representative of results that may be shown in actual dynamometer tests. This report should therefore be used as a guide for comparative vehicle performance.

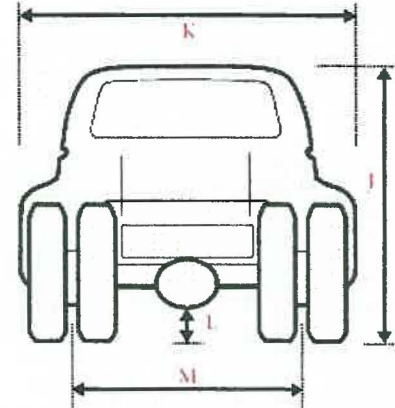
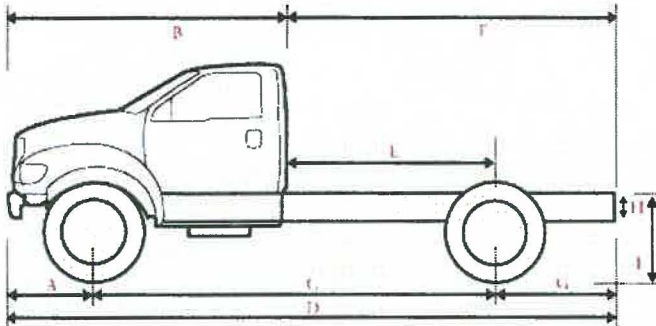

### Dimensions

A	Front of Bumper to Front Axle	39.00 in.
B	Front Bumper to Back of Cab (BBC)	113.00 in.
C	Wheelbase (WB)	158.00 in.
D	Overall Length (OAL)	246.00 in.
E	Back of Cab to Rear Axle (CA)	84.00 in.
F	Back of Cab to End of Frame	133.00 in.
G	Rear Axle to End of Frame (AF)	49.00 in.
H	Frame Section Height	10.40 in.
I	Rear Frame Height Unloaded	38.30 in.
I	Rear Frame Height Loaded	37.10 in.
J	Cab Height	94.30 in.
K	Body Width	96.70 in.
L	Maximum Ground Clearance	N/A
L	Minimum Ground Clearance	N/A
M	Front Tread	81.60 in.
M	Rear Tread	72.70 in.

### Body Specs

Truck body style:	DUMP
Cab to body gap:	3.00 in.
Body length:	10.80 ft
Body tare weight:	2,500 lbs
Body width:	96 in.
Body height from ground:	114 in.
Body Centre gravity (from front):	65.00 in.

Prices and content availability as shown are subject to change and should be treated as estimates only. Actual base vehicle, package and option pricing may vary from this estimate because of special local pricing, availability or pricing adjustments not reflected in the dealer's computer system. See salesperson for the most current information.



## Performance (cont'd)

### Trailer Towing Specs

Trailer Type:	DUMP
Weight of trailer:	3,000.00 lbs
Weight of trailer cargo:	12,000 lbs
Type of hitch:	PINTLEHOOK
Hitch Weight:	150 lbs
Hitch Factor:	15 %

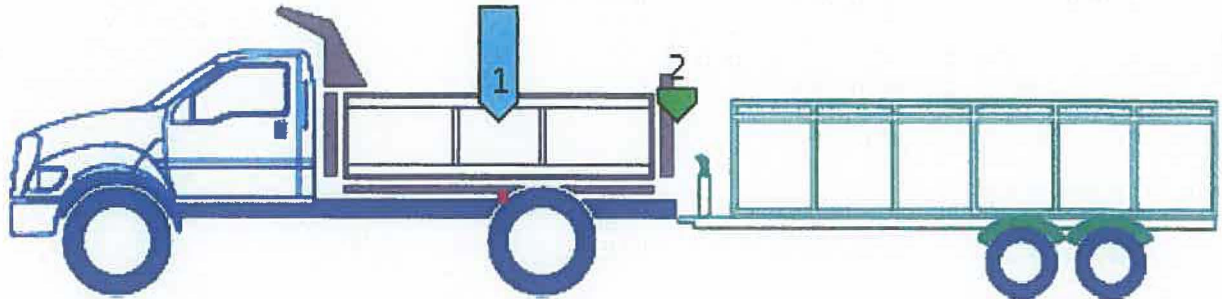

Prices and content availability as shown are subject to change and should be treated as estimates only. Actual base vehicle, package and option pricing may vary from this estimate because of special local pricing, availability or pricing adjustments not reflected in the dealer's computer system. See salesperson for the most current information.

Prepared for: DAVID MARQUEZ, Superintendent, City of Las Vegas Utilities Dept  
By: Darrel Clement Date: 11/28/2016 | Price Level: 745 Quote ID: 112816



## Performance (cont'd)

### Weight

GVW	Front Axle	Rear Axle	Totals
Chassis	6,783 lbs	4,322 lbs	11,105 lbs
Body	253 lbs	2,247 lbs	2,500 lbs
Occupant	200 lbs	100 lbs	300 lbs
Fuel	70 lbs	35 lbs	105 lbs
Hitch Weight:	-47 lbs	197 lbs	150 lbs
1 Water Level - (Water Level)	1,730 lbs	15,349 lbs	17,079 lbs
2 Tongue Weight - (Tongue Weight)	-698 lbs	2,948 lbs	2,250 lbs
<b>TOTAL</b>	<b>8,291 lbs</b>	<b>25,198 lbs</b>	<b>33,489 lbs</b>

Ratings	Front Axle	Rear Axle	GVWR
GAWR	12,000 lbs	26,000 lbs	37,000 lbs
Wheels/Tires	15,660 lbs	27,760 lbs	
Suspension	12,000 lbs	31,000 lbs	
Axle	12,000 lbs	26,000 lbs	
Legal Axle Limit	0 lbs	0 lbs	

Selected Options that limit GVWR	Totals
539 Single Channel - Straight 'C' 20.11 SM, 120,000 PSI	37,000 lbs

GCW	Totals
Adjusted GVW	31,239 lbs
Weight of trailer:	3,000 lbs
Weight of trailer cargo:	12,000 lbs
<b>TOTAL</b>	<b>46,239 lbs</b>
<b>GCWR</b>	<b>50,000 lbs</b>

Prices and content availability as shown are subject to change and should be treated as estimates only. Actual base vehicle, package and option pricing may vary from this estimate because of special local pricing, availability or pricing adjustments not reflected in the dealer's computer system. See salesperson for the most current information.



## Performance (cont'd)

### Start, Grade and Speed

#### Start Indicator

Vehicle equipped without Park Pawl. Shift indicator will display RNDM.

Start	Ratio	Desired	Calculated
Start grade capability in 1st gear	3.97	18.00 %	18.46 %
Start grade capability in reverse	3.13	15.00 %	14.53 %
Grade	Ratio	Desired	Calculated
Maximum grade in 4th gear	1.15	5.50 %	5.76 %
Maximum grade in 5th gear	0.86	4.00 %	4.30 %
Maximum grade in 6th gear	0.67	3.00 %	3.38 %
Speed		Desired	Calculated
Top Speed (level grade)		75 mph	88 mph
<i>To meet your requirement you need a maximum axle ratio of 8.06</i>			
Top Speed on 3.0% grade		55 mph	
<i>To meet your requirement you need a maximum of 286 hp</i>			
Cruise Speed		60 mph	60 mph
Engine RPM at desired cruise speed			2,306 rpm

### Variables in Use

Rear axle ratio:	6.83/6.83	Governed RPM:	3,400 rpm
Tire size:	295/80R22.5 (501 rev/mile)	Frontal Area:	57.28 Sq.Ft.
Gross Combined Weight (GCW):	46,239 lbs	Cruising RPM	2,300 rpm
Clutch engagement torque:	363 ft.lbs.	Worst road surface	Hard Packed Natural Soil
Torque conversion ratio:	1.85	Final Drive Ratio:	0.67
Peak engine torque:	725 ft.lbs.	Drag Coefficient	0.80
Engine Power:	330 hp @ 2,600 rpm		

Prices and content availability as shown are subject to change and should be treated as estimates only. Actual base vehicle, package and option pricing may vary from this estimate because of special local pricing, availability or pricing adjustments not reflected in the dealer's computer system. See salesperson for the most current information.

Prepared for: DAVID MARQUEZ, Superintendent, City of Las Vegas Utilities Dept  
 By: Darrel Clement Date: 11/28/2016 | Price Level: 745 Quote ID: 112816



## Performance (cont'd)

### Shift Chart

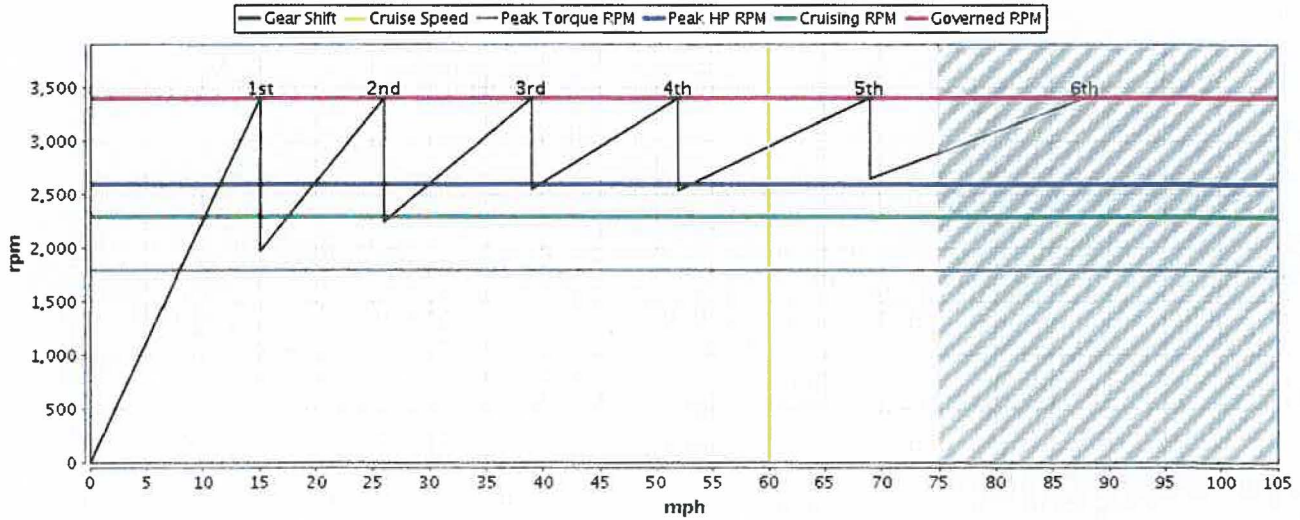

### Turning Radius

Turning radius to curb: 21.92 ft  
 Turning radius to bumper: 23.49 ft

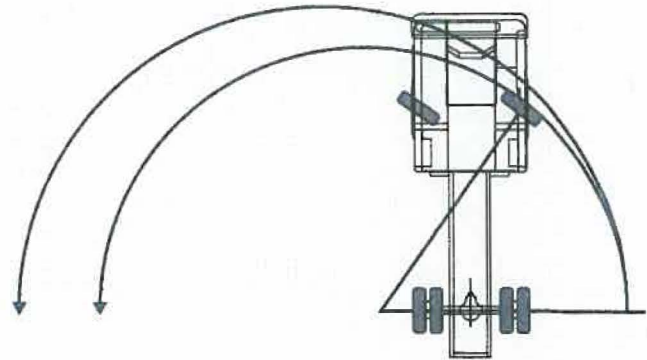

Prices and content availability as shown are subject to change and should be treated as estimates only. Actual base vehicle, package and option pricing may vary from this estimate because of special local pricing, availability or pricing adjustments not reflected in the dealer's computer system. See salesperson for the most current information.



## Selected Equipment & Specs

### Dimensions

- \* Exterior length: 246.0"
- \* Exterior height: 94.3"
- \* Front track: 81.6"
- \* Front legroom: 41.4"
- \* Front hiproom: 67.6"
- \* Exterior width: 96.7"
- \* Wheelbase: 158.0"
- \* Rear track: 72.7"
- \* Front headroom: 40.7"
- \* Front shoulder room: 68.0"

### Powertrain

- \* 330hp 6.7L OHV 32 valve intercooled turbo V-8 engine with diesel direct injection federal
- \* Rear-wheel drive
- \* Fuel Economy Highway: N/A
- \* Fuel/water separator
- \* Standard rear differential
- \* Right mounted horizontal tailpipe
- \* Recommended fuel : diesel
- \* 6 speed automatic transmission with overdrive
- \* Fuel Economy Cty: N/A
- \* 65.0 gal. rectangular Left front fuel tank
- \* Transmission PTO provision
- \* Right mounted horizontal muffler

### Suspension/Handling

- \* Front non-independent leaf spring suspension with anti-roll bar
- \* Hydraulic power-assist re-circulating ball Steering
- \* Metric measure truck tire 295/80R22.5 HBSW AS front and rear tires
- \* Rear rigid axle leaf spring suspension with regular shocks
- \* Front and rear 22.5 x 7.5 wheels
- \* Dual rear wheels

### Body Exterior

- \* 2 doors
- \* Black door mirrors
- \* Side steps
- \* Clearcoat paint
- \* Hood mounted grille
- \* Driver and passenger heated folding door mirrors
- \* Black bumpers
- \* Trailer harness
- \* Straight front bumper ends
- \* Front and rear 22.5 x 7.5 white steel wheels with 10 wheel studs

### Convenience

- \* Manual air conditioning
- \* Manual front windows
- \* Manual tilt steering wheel
- \* Front cupholders
- \* Dual electric horn
- \* Driver and passenger door bins
- \* Cruise control with steering wheel controls
- \* Manual door locks
- \* Wireless phone connectivity
- \* Passenger visor mirror
- \* Automatic gearshift steering column lever

### Seats and Trim

- \* Seating capacity of 2
- \* Fixed passenger seat
- \* Folding seat back
- \* Driver seat air suspension
- \* Manual fore/aft seats
- \* Fixed driver seat
- \* Bucket driver seat, Bucket passenger seat
- \* Driver seat with high back, passenger seat with low back
- \* 4 way seat direction
- \* Fixed driver seat headrest

### Entertainment Features

- \* AM/FM stereo radio with radio data system
- \* MP3 decoder
- \* External memory control
- \* Single CD player
- \* Auxiliary audio input
- \* Steering wheel mounted radio controls

Prices and content availability as shown are subject to change and should be treated as estimates only. Actual base vehicle, package and option pricing may vary from this estimate because of special local pricing, availability or pricing adjustments not reflected in the dealer's computer system. See salesperson for the most current information.



## Selected Equipment & Specs (cont'd)

- \* 4 speakers
- \* Fixed antenna
- \* Wireless streaming

### Lighting, Visibility and Instrumentation

- \* Halogen aero-composite headlights
- \* Light tinted windows
- \* Tachometer
- \* Trip computer
- \* RNDM
- \* Variable intermittent front windshield wipers
- \* Front reading lights
- \* Oil pressure gauge
- \* Trip odometer

### Safety and Security

- \* 4-wheel ABS brakes
- \* ABS traction control
- \* Air brakes
- \* Manual door locks

### Dimensions

#### General Weights

Curb	11105 lbs.	Front curb weight	6783 lbs.
Rear curb weight	4322 lbs.	Front axle capacity	12000 lbs.
Rear axle capacity	26000 lbs.	Front spring rating	12000 lbs.
Rear spring rating	31000 lbs.	Front tire/wheel capacity	15660 lbs.
Rear tire/wheel capacity	27760 lbs.	Front GAWR	12000 lbs.
Rear GAWR	26000 lbs.	GVWR	37000 lbs.
GCWR	50000 lbs.		

#### Trailing Type

Harness Yes

#### Fuel Tank type

Capacity 65 gal.

#### Front Frame

Height loaded 35 "      Height unloaded 37 "

#### Rear Frame

Height loaded 37 "      Height unloaded 38 "

#### Selected Options that limit GVWR

Single Channel - Straight 'C' 20.11 SM, 120,000 PSI 539

### Powertrain

#### Engine Type

Block material	Iron	Cylinders	V-8
Head material	Aluminum	Ignition	Compression
Injection	Diesel direct injection	Liters	6.7L
Orientation	Longitudinal	Recommended fuel	Diesel
Valves per cylinder	4	Valvetrain	OHV
Forced induction	Intercooled turbo		

#### Engine Spec

Bore	3.90"	Compression ratio	16.2:1
Displacement	406 cu.in.	Stroke	4.25"

#### Engine Power

Prices and content availability as shown are subject to change and should be treated as estimates only. Actual base vehicle, package and option pricing may vary from this estimate because of special local pricing, availability or pricing adjustments not reflected in the dealer's computer system. See salesperson for the most current information.





## Selected Equipment & Specs (cont'd)

Output Governed RPM	330 HP @ 2,600 RPM 3400	Torque	725 ft.-lb @ 1,800 RPM
<b>Alternator</b>			
Type	HD	Amps	200
<b>Battery</b>			
Cold cranking amps Step	1800 Yes	Location Type	Forward right Dual
<b>Engine Extras</b>			
Block heater	Yes		
<b>Transmission</b>			
Electronic control Overdrive Type	Yes Yes Automatic	Lock-up Speed	Yes 6
<b>Transmission Gear Ratios</b>			
1st	3.974	2nd	2.318
3rd	1.516	4th	1.149
5th	0.858	6th	0.674
Reverse Gear ratios	3.128		
<b>Transmission Torque Converter</b>			
Stall ratio	1.85		
<b>Transmission Extras</b>			
Driver selectable mode Oil cooler	Yes Regular duty	Sequential shift control PTO provision	Yes Yes
<b>Drive Type</b>			
Type	Rear-wheel		
<b>Drive Feature</b>			
Traction control	ABS		
<b>Drive Axle</b>			
Ratio	6.83		
<b>Exhaust</b>			
Material	Aluminized steel	System type	Single
<b>Emissions</b>			
CARB	Federal		
<b>Engine Retarder</b>			
Type	Yes		
<b>Driveability</b>			
<b>Brakes</b>			
ABS Type	4-wheel Air brakes	ABS channels	4
<b>Suspension Control</b>			
Ride	Regular		

Prices and content availability as shown are subject to change and should be treated as estimates only. Actual base vehicle, package and option pricing may vary from this estimate because of special local pricing, availability or pricing adjustments not reflected in the dealer's computer system. See salesperson for the most current information.



## Selected Equipment & Specs (cont'd)

### Front Suspension

Independence	Non-independent	Type	Leaf
Anti-roll bar	Regular		

### Front Spring

Type	Tapered leaf	Grade	Regular
------	--------------	-------	---------

### Front Shocks

Type	Regular
------	---------

### Rear Suspension

Independence	Rigid axle	Type	Leaf
--------------	------------	------	------

### Rear Spring

Type	Multi-leaf	Grade	Regular
------	------------	-------	---------

### Rear Shocks

Type	Regular
------	---------

### Steering

Activation	Hydraulic power-assist	Type	Re-circulating ball
------------	------------------------	------	---------------------

### Steering Specs

# of wheels	2
-------------	---

## Exterior

### Front Wheels

Diameter	22.5"	Width	7.50"
----------	-------	-------	-------

### Rear Wheels

Diameter	22.5"	Width	7.50"
Dual	Yes		

### Front Tires

Aspect	80	Diameter	22.5"
Sidewalls	BSW	Tread	AS
Width	295mm	LT load rating	H
RPM	501		

### Rear Tires

Aspect	80	Diameter	22.5"
Sidewalls	BSW	Tread	AS
Width	295mm	LT load rating	H
RPM	501		

### Wheels

Front track	81.6"	Rear track	72.7"
Turning radius (to curb)	22'	Turning radius (to bumper)	23'
Wheelbase	158.0"		

### Body Features

Front splash guards	Yes	Rear splash guards	Holder only
Body material	Composite/galvanized steel	Side steps	Yes

### Body Doors

Door count	2
------------	---

Prices and content availability as shown are subject to change and should be treated as estimates only. Actual base vehicle, package and option pricing may vary from this estimate because of special local pricing, availability or pricing adjustments not reflected in the dealer's computer system. See salesperson for the most current information.



## Selected Equipment & Specs (cont'd)

### Exterior Dimensions

Length	246.0"	Body width	96.7"
Body height	94.3"	Cab to axle	84.0"
Axle to end of frame	49.0"	Frame section modulus	20.1cu.in.
Frame yield strength (psi)	120000.0	Frame rail depth	10.4"
Frame rail width	3.7"	Frame rail thickness	0.4"
Max RBM (in.-lbs.)	2526000.0	Frame rail section	9.5"
Front bumper to Front axle	39.0"	Nominal RBM (in.-lbs.)	2413200.0

### Seating

#### Passenger Capacity

Capacity	2
----------	---

#### Driver Seat

Type	Bucket	Back Suspension	Folding Air
Back type	High	Fore/aft	Manual
Way direction control	4		

#### Driver Headrest

Type	Fixed
------	-------

#### Passenger Seat

Type	Bucket	Back Way direction control	Folding 4
Back type	Low		
Fore/aft	Manual		

#### Front Seat Trim

Material	Vinyl	Back material	Carpet
----------	-------	---------------	--------

### Convenience

#### AC And Heat Type

Air conditioning	Manual
------------------	--------

#### Audio System

CD	Single	CD location	In-dash
MP3 decoder	MP3 decoder	Auxiliary audio input	Yes
Radio	AM/FM stereo	Radio data system	Yes
Radio grade	Regular	Seek-scan	Yes
External memory control	External memory		

#### Audio Speakers

Speaker type	Regular	Speakers	4
--------------	---------	----------	---

#### Audio Controls

Steering wheel controls	Yes	Voice activation	Yes
Wireless streaming	Yes		

#### Audio Antenna

Type	Fixed
------	-------

#### Cruise Control

Cruise control	With steering wheel controls
----------------	------------------------------

Prices and content availability as shown are subject to change and should be treated as estimates only. Actual base vehicle, package and option pricing may vary from this estimate because of special local pricing, availability or pricing adjustments not reflected in the dealer's computer system. See salesperson for the most current information.



## Selected Equipment & Specs (cont'd)

### Convenience Features

12V DC power outlet	2	Wireless phone connectivity	Yes
AC power outlet	1	Back-up alarm	Yes
Horn	Dual electric		

### Door Lock Activation

Type	Manual		
------	--------	--	--

### Instrumentation Type

Display	Analog		
---------	--------	--	--

### Instrumentation Gauges

Tachometer	Yes	Oil pressure	Yes
Engine temperature	Yes	Transmission fluid temp	Yes
Engine hour meter	Yes	Primary air pressure	Yes

### Instrumentation Warnings

Battery	Yes	Lights on	Yes
Key	Yes	Service interval	Yes
Brake fluid	Yes	Transmission fluid temp	Yes

### Instrumentation Displays

Clock	In-radio display		
-------	------------------	--	--

### Instrumentation Feature

Trip computer	Yes	Trip odometer	Yes
Shift indicator	RNDM		

### Steering Wheel Type

Material	Urethane	Tilting	Manual
----------	----------	---------	--------

### Front Side Windows

Window 1st row activation	Manual		
---------------------------	--------	--	--

### Window Features

Tinted	Light		
--------	-------	--	--

### Front Windshield

Wiper	Variable intermittent		
-------	-----------------------	--	--

### Rear Windshield

Window	Fixed		
--------	-------	--	--

### Automatic Gearshift

Location	Steering column lever		
----------	-----------------------	--	--

## Interior

### Passenger Visor

Mirror	Yes		
--------	-----	--	--

### Headliner

Coverage	Full	Material	Cloth
----------	------	----------	-------

### Floor Trim

Coverage	Full	Covering	Vinyl/rubber
----------	------	----------	--------------

### Trim Feature

Prices and content availability as shown are subject to change and should be treated as estimates only. Actual base vehicle, package and option pricing may vary from this estimate because of special local pricing, availability or pricing adjustments not reflected in the dealer's computer system. See salesperson for the most current information.



## Selected Equipment & Specs (cont'd)

Gear shift knob	Urethane		
<b>Lighting</b>			
Dome light type	Delay	Front reading	Yes
Variable IP lighting	Yes		
<b>Floor Console Storage</b>			
Type	Partial		
<b>Storage</b>			
Driver door bin	Yes	Front Beverage holder(s)	Yes
Glove box	Yes	Passenger door bin	Yes
Dashboard	Yes		
<b>Legroom</b>			
Front	41.4"		
<b>Headroom</b>			
Front	40.7"		
<b>Hip Room</b>			
Front	67.6"		
<b>Shoulder Room</b>			
Front	68.0"		

Prices and content availability as shown are subject to change and should be treated as estimates only. Actual base vehicle, package and option pricing may vary from this estimate because of special local pricing, availability or pricing adjustments not reflected in the dealer's computer system. See salesperson for the most current information.

Good morning David,

I've been told unofficially that Municipalities are not taxed on vehicle purchases by the State and that the Federal Excise Tax (FET) that might be otherwise due on vehicles with GVWRs that exceed 33,000 lbs. is not levied. The State does charge a fee for the registration and plates and that is typically paid at the time of registration by the Municipal entity at the time of registration. Please consider this completely unofficial and not a binding opinion. An inquiry with the State Department of Transportation by your City/County Legal Council would be highly recommended. Also, although we are proposing a F-750 that will have a GVWR in excess of 33,000 lbs., we can "de-rate" the chassis to 32,999 (still requires a CDL class A license) while we maintain the technical capabilities. In short, that means that you have a truck which is capable of much higher weight capacity than what it can be legally loaded with. It will take some training on your part to educate your drivers what 33,000 lbs. looks like loaded on the truck so they aren't surprised at a scale. This approach will provide you with a higher performing vehicle and one that will last significantly longer with proper care and maintenance.

The warranty is multi-faceted. I have attached a copy of the description for you to review and understand.

Please let me know if you have any other questions and I'll gladly find the answers.

Thank you,

***Darrel Clement***

**Commercial Account Manager**

**Don Chalmers Ford**

**[dclement@donchalmersford.com](mailto:dclement@donchalmersford.com)**

**505 890-2152 office**

**505 235-0698 mobile**



David,

Regarding the warranties, we would have 2 year warranties on the engine, axles and transmission. Those are standard warranties. I can add extended warranties to the quote for up to 5 years. That would drive the overall price up. What do you think?

Luis Garcia  
Truck Sales  
Summit Truck Group  
Office: 505-243-7883



Don Chalmers Ford  
 2500 Rio Rancho Blvd, S.E., Rio Rancho, New  
 Mexico, 871241095  
 Office: 505-897-2500

**2017 F-750 Diesel, Regular Cab**  
**Regular Cab Base(F7D)**  
 Price Level: 745 Quote ID: 112816

## Warranty - Standard Equipment & Specs

### Warranty

#### *Basic*

Distance	Unlimited miles	Months	24 months
----------	-----------------	--------	-----------

#### *Powertrain*

Distance	Unlimited miles	Months	24 months
----------	-----------------	--------	-----------

#### *Corrosion Perforation*

Distance	Unlimited miles	Months	36 months
----------	-----------------	--------	-----------

#### *Roadside Assistance*

Distance	Unlimited miles	Months	24 months
----------	-----------------	--------	-----------

#### *Diesel Engine*

Distance	250000 miles	Months	60 months
----------	--------------	--------	-----------

#### *Transmission*

Distance	250000 miles	Months	60 months
----------	--------------	--------	-----------

Prices and content availability as shown are subject to change and should be treated as estimates only. Actual base vehicle, package and option pricing may vary from this estimate because of special local pricing, availability or pricing adjustments not reflected in the dealer's computer system. See salesperson for the most current information.

Prepared for: DAVID MARQUEZ, Superintendent, City of Las Vegas Utilities Dept  
 By: Darrel Clement Date: 12/19/2016



Work Session

**CITY COUNCIL MEETING AGENDA REQUEST**

**DATE:** 12/30/16

**DEPT:** Utilities Dept.

**MEETING DATE:** 01/11/17

**DISCUSSION ITEM/TOPIC:** Award request for bids #2017-12 for natural gas inventory supplies to multiple bidders.

**BACKGROUND/RATIONALE:** The City of Las Vegas Gas Division must keep their inventory supplies stocked and on hand for gas line repairs as needed. We would like to award to all bidders as prices are lower on different materials for each vendor.

Advertised: 11/16/16; Las Vegas Optic, Albuquerque Journal and City Website  
Bid Opening: December 1, 2016  
Number of Proposers: 3 – Secor, Koons Gas Measurement, Mountain States Pipe and Supply  
Amount: See attached bid tabulation.  
Funding Source: City Funds  
Budget Line Item: 620-0000-610-7407

**THIS REQUEST FORM MUST BE SUBMITTED TO THE CITY CLERK'S OFFICE NO LATER THAN 5:00 P.M. ON FRIDAY ONE AND A HALF WEEKS PRIOR TO THE CITY COUNCIL MEETING.**

  
SUBMITTER'S SIGNATURE

**REVIEWED AND APPROVED BY:**

  
TONITA GURULE-GIRON  
MAYOR

  
RICHARD TRUJILLO  
CITY MANAGER

\_\_\_\_\_  
ANN MARIE GALLEGOS  
FINANCE DIRECTOR  
(PROCUREMENT)

\_\_\_\_\_  
PURCHASING AGENT  
(FOR BID/RFP AWARD)

\_\_\_\_\_  
H. CHICO GALLEGOS  
CITY ATTORNEY  
(ALL CONTRACTS MUST BE  
REVIEWED)

PROPOSAL/BID OPENING

DATE: 1-Dec-2016

OPENING NO.: 2017-12

TIME: 3:00 PM

DEPARTMENT: UTILITIES/GAS

LOCATION: City of Las Vegas Chambers  
1700 N. Grand Ave.  
Las Vegas, NM 87701

ITEM(S): NATURAL GAS INVENTORY SUPPLIES

RECEIVED FROM:	AMOUNT	BID BOND	AFFIDAVIT NOTARIZED	CAMPAIGN DISC. FORM
Secor	Award will be		✓	✓
	multi-bid lowest			
KGm (Koons Gas Measurement)	bidder by department		✓	✓
	" "			
MSPS (Mountain States Pipe and Supply)	" "		✓	✓
	" "			
	" "			
	" "			

COMPANY REPRESENTATIVE

COMPANY NAME

	City of Las Vegas Gas Dept.
	City of Las Vegas Gas
	City of Las Vegas Gas
	City of Las Vegas Purchasing

(use other side of form when full)

COPIES TAKEN BY:   
 DATE: 12/1/16

OPENED BY: FINANCE DEPARTMENT  
  
 DATE: 12/1/16

**CITY OF LAS VGAS**

**BID ITEM (S): NATURAL GAS INVENTORY SUPPLY**

ITEM	DESCRIPTION	SECOR	MSPS	KGM
1.	Roots-Series B3 Line Mount Meter's 11-M175 (TC)-4" Flange 8 Bolt	No Bid	\$2925.00 (ROMET RM11000 TC)	\$3741.00
2.	American AL-1400 Diaphragm Meter 2" NPT 100 PSIG MAOP	No Bid	\$3500.00	Refurbished \$1595.00(2yr warranty)
3.	American AL-800 Diaphragm Meter 45LT 1-1 1/2" NPT	No Bid	\$1540.00	Refurbished \$995.00 (2yr warranty)
4.	American AL-2300 Diaphragm Meter 4" flanged connection 100psig MAOP	No Bid	\$5230.00	Refurbished \$2600.00 (2yr warranty)
5.	American AL-5000 Diaphragm Meter 4" flanged connection 100 psig MAOP	No Bid	\$6765.00	Refurbished \$3425.00 (2ys warranty)
6.	American 425 Natural Gas Meter	No Bid	\$415.00 (4pc min)	Refurbished \$290.00 (2yr warranty)
7.	American AC 630 Natural Gas Meter	No Bid	\$820.00 (4pc min)	Refurbished \$475.00 (2yr warranty)
8.	American AL-1000 Diaphragm meter 45LT, 1-1 1/2" NPT	No Bid	\$1885.00 (2pc min)	Refurbished \$1050.00 (2yr warranty)
9.	750/1600 Natural Gas Meter w/max working pressure 100lb – w/standard connections 45LT	No Bid	\$2375.00 (2pc min)	Refurbished \$1050.00 (2yr warranty)
10.	1000 Natural Gas Meter working pressure 25lb	No Bid	No Bid	Refurbished \$1050.00 (2yr)

			warranty)
11.	Model-441-57S Self-Operated Low and High Pressure Large Capacity Regulators 4" 8 Bolt Flange ASME	No Bid	No Bid
12.	Model-046-2Field High Pressure Service Regulator 1"x1"	No Bid	No Bid
13.	275 TC Meter w/1" connections, galvanized. One side insulated. Or equal	No Bid	Refurbished \$74.50 (2yr warranty)
14.	2" x 2" 243-8-2 regulator IRV, 6" to 14" spring, w/3/8 orifice. Or equal	No Bid	No Bid
15.	2" x 2" 243-HP Regulator, IRV w/1/2" orifice. 3 PSI to 10 PSI or equal to	No Bid	No Bid
16.	1" x1" 143-80-2 regulator. IRV 6" to 14" spring. 3/8" orifice. Or equal	No Bid	No Bid
17.	3/4" x 3/4" Model 496 regulator. IRV 6" to 14" spring. 1/8" orifice. Or equal	No Bid	No Bid
18.	1" x 1" 143-80-2 HP regulator IRV 2 -6 PSI, 3/8" orifice. Or equal	No Bid	No Bid
19.	1" x 1" Model 496 regulator IRV 6" to 14" spring. 1/8" orifice. Or equal	No Bid	No Bid
20.	2 x 2-243-RPC-B Regulator. 1/2" orifice – 10 PSIG-35 PSI. Or equal	No Bid	No Bid
21.	45LT x 1 1/4" galvanized gas meter connection Per Set	No Bid	\$27.84 (5pc min) \$9.25 (1ea swivel/nut/gasket)
22.	45LT x 1 1/2" galvanized insulated gas meter connection. Per Set Insulated	No Bid	\$29.00 (5pc min) \$9.75 (1ea insulated swivel/ nut/gasket)
23.	20LT x 1" M.P.T. galvanized swivel & nut Per Set - Insulated	No Bid	\$13.62 (50 pc min) \$7.00 (1ea insulated swivel/ nut/

			gasket)
24.	¾" Polyethylene Gas Pipe Performance Pipe PE 3408– A.S.T.M-D-2513 or equal	\$1.56 per ft.	No Bid No Bid
25.	1" Polyethylene Gas Pipe Performance Pipe PE 3408– A.S.T.M-D-2513 or equal	\$1.71 per ft.	No Bid No Bid
26.	1 ¼" Polyethylene Gas Pipe Performance Pipe PE 3408– A.S.T.M-D-2513 or equal	\$1.99 per ft.	No Bid No Bid
27.	2" Polyethylene Gas Pipe Performance Pipe PE 3408 – A.S.T.M-D-2513 or equal	\$2.59 per ft.	No Bid No Bid
28.	4" Polyethylene Gas Pipe Performance Pipe PE 3408– A.S.T.M-D-2513 or equal	\$9.88 per ft.	No Bid No Bid
29.	4" IPS Transition fitting steel weld end x PE 3408 butt connection– A.S.T.M-D-2513	\$91.76 ea.	\$125.00 No Bid
30.	2" IPS Transition fitting steel weld end x PE 3408 Butt connection– A.S.T.M-D-2513	\$50.67 ea.	\$48.00 No Bid
31.	1" IPS Transition fitting steel weld end x PE 3408 Butt connection– A.S.T.M-D-2513	\$37.47 ea.	\$35.00 No Bid
32.	PQ-11-Bypass Tee 2" IPS main x 2" IPS Abandonment outlet Part#-5662-17-1017-00 Continental Industries	\$274.33 ea.	No Bid No Bid
33.	4" PE 3408 butt fusion connection cap– A.S.T.M-D-2513	\$22.87 ea.	\$18.18 (10pc min) No Bid
34.	2" PE 3408 butt fusion connection cap– A.S.T.M-D-2513	\$13.13 ea.	\$3.93 (10pc min) No Bid
35.	1" PE 3408 butt fusion connection cap– A.S.T.M-D-2513	\$14.07 ea.	\$8.25 (10 pc min) No Bid
36.	4"x 2 PE 3408 butt fusion connection – A.S.T.M-D-2513 Reducer	\$21.56 ea.	\$19.17 (10pc min) No Bid
37.	2" x 1" PE 3408 butt fusion connection – A.S.T.M-D-2513 Reducer	\$15.87 ea.	\$11.88 (10pc min) No Bid

38.	1 1/4" x 1" PE 3408 butt fusion connection Reducer	\$18.79 ea	\$13.38 (10pc min)	No Bid
39.	1" x 3/4" PE 3408 butt fusion connection Reducer	\$17.43 ea.	\$9.57 (10pc min)	No Bid
40.	1 1/4" x 2" PE 3408 butt fusion connection Reducer	\$15.97 ea.	\$12.12 (10pc min)	No Bid
41.	1 1/4" PE 3408 butt fusion connection cap	\$13.71 ea.	\$5.49 (10pc min)	No Bid
42.	2" PE 3408 butt fusion connection Tee – A.S.T.M-D-2513 Tee	\$17.70 ea.	\$9.65 (10pc min)	No Bid
43.	4" PE 3408 butt fusion connection Tee – A.S.T.M-D-2513 Tee	\$37.31 ea.	\$32.46 (10pc min)	No Bid
44.	1" PE 3408 butt fusion connection 90 degree elbow-A.S.T.M-D2513	\$14.51 ea.	\$9.85 (10pc min)	No Bid
45.	1 1/4" PE 3408 butt fusion connection 90 degree elbow– A.S.T.M-D-2513	\$15.36 ea.	\$10.35 (10pc min)	No Bid
46.	1" Butt fusion connection Tee– A.S.T.M-D-2513	\$15.79 ea.	\$10.95 (10pc min)	No Bid
47.	2" PE 3408 butt fusion connection 90 degree elbow– A.S.T.M-D-2513	\$15.99 ea.	\$8.16 (10pc min)	No Bid
48.	4" PE 3408 butt fusion connection 90 degree elbow– A.S.T.M-D-2513	\$32.76 ea.	\$25.20 (4pc min)	No Bid
49.	2" x 1" PE tapping tee assembly– A.S.T.M-D-2513	\$31.43 ea.	No Bid	No Bid
50.	2" x 2" PE tapping tee assembly– A.S.T.M-D-2513	\$124.29 ea.	No Bid	No Bid
51.	4" x 1" PE tapping tee assembly	\$31.43 ea.	No Bid	No Bid
52.	4" x 2" PE tapping tee assembly	\$124.29 ea.	No Bid	No Bid
Note: Tapping tee assemblies to be adaptable to performance pipe PE 3408 fusion connections or equal				
53.	Anodeless service riser. 1" x1" By pass -SDR-11-P.E.	No Bid	No Bid	No Bid

54.	3408 R.W. Lyall or equal– A.S.T.M-D-2513 Anodeless service riser. 1" IPS x 1" NPT-SDR-11-P.E. 3408 R.W. Lyall or equal– A.S.T.M-D-2513	\$58.87 ea.	\$55.00 (10pc min)	No Bid
55.	Anodeless service riser. 2" NPT x 2" IPS SDR11-P.E. 3408 R.W. Lyall or equal– A.S.T.M-D-2513	\$141.24 ea.	\$175.00 (5pc min)	No Bid
56.	2" PE 3408 Valve– A.S.T.M-D-2513	\$118.11 ea.	\$140.00 (2pc min)	No Bid
57.	4" PE 3408 Valve– A.S.T.M-D-2513	\$350.43 ea.	\$355.00 (2pc min)	No Bid
58.	2" x 2"-175 Mueller Lubeseal in line pvc valve	\$176.69 ea. (H-11175)	\$88.00	No Bid
59.	2" x 1" gas service saddle PVC w/compression outlet. Continental #5361-1014 or equal	\$92.89 ea (#5864-17-1014-00)	No Bid	No Bid
60.	1 1/4" pipe joint clamp MB Skinner #089862 or equal	\$239.29 ea.	No Bid	No Bid
61.	1 1/2" pipe joint clamp MB Skinner #089861 or equal	\$253.57 ea.	No Bid	No Bid
62.	2" pipe joint clamp MB Skinner #089860 or equal	\$260.71 ea.	No Bid	No Bid
63.	4" line stopper fitting 250 P.S.I. Mueller #H17190 or equal	\$211.69 ea.	\$170.39 (4pc min) \$72.76 (6pc min)	No Bid
64.	2" line stopper fitting 250 P.S.I. Mueller #H17190 or equal	\$101.86 ea.	No Bid	No Bid
65.	2" plug valve, lubricated w/flange connection. CI for gas	\$235.71 ea.	No Bid	No Bid
66.	2" plug valve, lubricated w/threaded ends. CI for gas	\$180.44 ea.	No Bid	No Bid
67.	4" plug valve, lubricated w/flange ends. CI for gas	\$499.00 ea.	No Bid	No Bid
68.	Meter barrel lock. Mueller #504979 or equal	\$20.71 ea.	\$10.00 (50pc min)	No Bid
69.	3" line stoppers fittings 250. P.S.I. Mueller	\$178.46 ea.	\$147.96	No Bid

			(5pc min)	
70.	¾" Mueller steel auto perf tee or equal	\$39.04 ea. (H-18102)	\$25.81 (25pc min)	No Bid
71.	1" Mueller steel autoperf tee or equal	\$48.07 ea. (H-18102)	\$33.84 (25pc min)	No Bid
72.	¾" IPS x 1" IPS transition Punch Tee	\$88.03 (H-18104-04)	\$69.36 (10pc min)	No Bid
73.	Thermoweld cartridge #15 CP Box of 20	\$51.71 ea.	\$70.00 (1 box min)	\$40.00 ea.
74.	2" PVC to PVC compression for gas	No Bid	No Bid	No Bid
75.	1" PVC T PVC compression coupling for gas	No Bid	No Bid	No Bid
76.	Lock wing iron body meter stop Inlet: 1" inside I.P. thread Outlet: 1" insulated union coupling w/inside I.P. thread. Finish: black or brass. 175 P.S.I.	\$103.19 ea.	\$49.62 (10pc min)	\$50.21 ea.
77.	Lock wing iron body meter stop Inlet: 1" inside I.P. thread Outlet: 1" inside I.P. thread Finish: Black or brass 175 P.S.I.	\$71.67 ea.	\$33.94 (15pc min)	\$21.75 ea.
78.	Tinker & Razor Half Cell reference electrodes Model-6-B-cucu 504 Half cell 1/ ¼" x 6"	\$103.57 ea.	No Bid	No Bid
79.	CuCu-504 crystals 1lb. 3ox bottle P#04-9011	\$45.71 ea.	No Bid	No Bid
80.	Ceramic Tip Assembly- Pointed P#118-027	\$36.43 ea.	No Bid	No Bid
81.	2 x 1 – PE 4710 HDPE Tapping Tee w/Rectangular Base & Model EFVEB-BB7YY00	\$73.81 ea.	No Bid	No Bid
82.	4 x 1 –PE-4710-HDPE Tapping Tee w/Rectangular Base & model EFVEB-BB7YY00 Excess Flow Valve	\$80.69 ea.	No Bid	No Bid
83.	Excess Flow Valve Model B – w/minimum Trip Point of 525SCFit @ 10 P.S.I. Stick Type	\$32.10 ea.	No Bid	No Bid
84.	2" PVC to 2" IPS Transition Fitting	\$70.36 ea.	No Bid	No Bid



85.	Valve Boxes Plastic for 2" to 3" FP Valve-31	\$138.40 ea.	No Bid	No Bid
86.	Valve Supports for 2" Valve	\$23.94 ea.	No Bid	No Bid
87.	Valve Supports for 4" Valve	\$35.53 ea.	No Bid	No Bid
88.	Trenton wax tape 6"x9' (16 rolls per case)	\$52.50 ea.	No Bid	No Bid
89.	Trenton wax tape primer brown (4 gal per case)	\$153.07 ea.	No Bid	No Bid
90.	Barricade tape Gas Line Below yellow & black (8 rolls per case)	\$32.86 ea.	\$18.50 per roll (8 roll min)	No Bid
91.	#12 Solid BC .030 w/yellow tracer wire 500 ft (500 ft rolls/ 4 rolls per case)	\$0.24 per ft.	\$0.20 per ft. (2000ft min)	No Bid
92.	Harveys 10 mil Pipe Wrap 2" x 100' (24 per case)	\$38.57 ea.	\$24.82 (3M#50 24 roll min)	No Bid
93.	Magnesium--Anode -- HC -- Potential -- 32lb	\$282.71 ea.	No Bid	\$160.00
94.	Magnesium -- Anodes -- 5lbs H.C	\$90.43 ea.	No Bid	\$31.07
95.	Magnesium-Anodes-9lb H.C.	\$135.79 ea.	\$70.00 (5pc min)	\$50.25
96.	Magnesium -- Anodes -- 17lbs H.C	\$201.86 ea.	\$130.00 (5pc min)	\$85.75
97.	Magnesium -- Anodes -- 50lbs H.C	\$474.14 ea. (48 LBS)	No Bid	\$235.75
98.	Leak Detection Low temp Leak locator	\$58.14 ea.	\$20.00 per gallon (4Gal min)	No Bid
99.	White/Yellow line locate paint, inverted marking paint	\$83.57	\$5.00 per can (24 can min)	No Bid

**REQUEST FOR BIDS**

The City of Las Vegas, New Mexico will open Sealed Bids at 2:00 p.m. Dec 1, 2016 at 3:00 pm the City Council Chambers, 1700 North Grand Avenue, Las Vegas, New Mexico, or other designated area at the City Offices; ON THE FOLLOWING:

**NATURAL GAS INVENTORY SUPPLIES**

The BIDDING FORMS AND TECHNICAL SPECIFICATIONS may be examined at the following location: 1700 NORTH GRAND, LAS VEGAS, NM

Copies of the BIDDING FORMS AND TECHNICAL SPECIFICATIONS may be obtained at the office of : 1700 NORTH GRAND, LAS VEGAS, NM

Mailed Bids should be addressed to the City Clerk, 1700 N. Grand Ave., Las Vegas, New Mexico 87701; with the envelope marked: NATURAL GAS INVENTORY SUPPLIES, Opening No. 2017-12; on the lower left-hand corner of the submitted envelope. It shall be the responsibility of the bidder to see that their bid is delivered to the City Clerk by the date and time set for the bid request. If the mail or delivery of bid request is delayed beyond the opening date and time, bid thus delayed will not be considered. A public opening will be held and any bidder or their authorized representative is invited to attend.

The City of Las Vegas reserves the right to reject any/or all bids submitted.

CITY OF LAS VEGAS,

Richard R. Trujillo  
RICHARD TRUJILLO, CITY MANAGER

H. Chico Gallegos  
H. CHICO GALLEGOS, CITY ATTORNEY

Cassandra Fresquez  
CASANDRA FRESQUEZ, CITY CLERK

Ann M. Gallegos  
ANN M. GALLEGOS, FINANCE DIRECTOR

Helen Vigil  
HELEN VIGIL, PURCHASING OFFICER

Opening No. 2017-12

Date Issued: 11/2/2016

Date Issued: Published: Albuquerque Journal Nov 16, 2016  
Las Vegas Optic Nov 16, 2016  
City website: [www.lasvegasnm.gov](http://www.lasvegasnm.gov)

## STANDARD BID CLAUSES

### AWARDED BID

Awarding of Bid shall be made to the responsible Bidder whose Bid meets the required specifications. The City of Las Vegas (City) reserves the right to reject or accept any of all Bid specifications and to waive any insubstantial irregularity in the form of the Bid.

The City of Las Vegas may make multiple awards of the bid, to those bidding in law enforcement related services. The City Reserves the right to award the bid to the most advantageous Bidder to the City.

### TIMETABLE

Bids pursuant to this request must be received at the City Clerk's Office at 1700 North Grand Avenue, Las Vegas, New Mexico, on or before 3:00 pm, Dec 1, 2016 at which time all bids received will be opened. An opening will occur at the City's Council Chambers or other designated area at the City Offices. Awarding of Bid is projected for \_\_\_\_\_, 20\_\_\_\_. The successful Bidder will be notified by mail.

### ENVELOPES

Sealed Bid envelopes shall be clearly marked on the lower left-hand corner, identified by the Bid Name and Opening Number. Failure to comply with this requirement may result in the rejection of your submitted Bid. Enclose one (1) original and two (2) copies of Bid.

### BRIBERY AND KICKBACK

The Procurement Code of New Mexico; (Section 13-1-28 through 13-1-99 N.M.S.A. 1978), impose a third degree felony penalty for bribery of a public official or public employee. In addition the New Mexico Criminal Statutes (Section 30-4-1, N.M.S.A. 1978): state that it is a third degree felony to commit the offense of demanding or receiving a bribe by a public official of public employee. And (Section 30-24-2, N.M.S.A. 1978): it is a fourth degree felony to commit the offense of soliciting or receiving illegal kickbacks. Also (Section 30-41-1 through 30-41-3, N.M.S.A. 1978): states that it is a fourth degree felony to commit the offense of offering or paying illegal kickbacks.

### NON-COLLUSION

In signing their Bid and Affidavit, the Bidder certifies that he/she has not, either directly or indirectly entered into action of restraint of free competition, in the connection with the submitted bid.

### RESPONSIBILITY OF BIDDER

At all times it shall be the responsibility of the Bidder to see their bid is delivered to the City Clerk by the Date and Time scheduled for opening. If the mail or delivery of said Bid is delayed beyond the scheduled opening date and time set, this bid will not be considered.

**CLARIFICATION OF BID**

Bidder requiring clarification or interpretation of Bid specifications shall make a written request to the Department involved in this bid request at least five (5) days prior to the scheduled bid opening date with a copy forwarded to the Finance Department. Any interpretation, corrections or changes of said Bid Specifications, Opening Date, or Time Change will be made by Addendum only. Interpretations, Corrections or changes of said bid made in any other manner will not be binding and the Bidder shall not rely upon such interpretation, corrections and changes.

**MODIFICATION OF BID**

Bids may be withdrawn upon receipt of written request prior to the scheduled bid opening for the purpose of making any corrections or changes. Such corrections must be properly identified and signed or initialed by the Bidder. Resubmission must be prior to the scheduled bid opening time in order to be considered. After bid opening, no price modifications of submitted bids or other provisions shall be permitted.

**WITHDRAWAL OF BID**

A low Bidder alleging a material mistake of fact, after bids have been opened may request their bid be withdrawn upon receipt of a written request to the Finance Department prior to the scheduled awarding date.

**INSPECTION**

Final inspection and acceptance will be made at the City's discretion. Products rejected for nonconformance with the specifications shall be removed by the Bidder; at his/her risk and expense promptly after notice of rejection.

**FEDERAL TAX IDENTIFICATION NUMBER**

Pursuant to IRS requirements, Bidder shall provide their Federal Tax ID Number if Bidder is incorporated. If Bidder is a sole proprietorship or partnership then they shall provide their Social Security Number.

FEDERAL TAX ID NUMBER: \_\_\_\_\_  
SOCIAL SECURITY NUMBER: \_\_\_\_\_

**NEW MEXICO TAX IDENTIFICATION NUMBER**

Payment may be withheld under (Section 7-10-5, N.M.S.A. 1978) if you are subject to New Mexico Gross Receipts Tax and have not registered for a New Mexico (CRS) Tax Identification Number. Contact the New Mexico Taxation & Revenue Department at (505) 827-0700 for registering instructions.

NEW MEXICO TAX IDENTIFICATION NO. (CRS): \_\_\_\_\_

## CAMPAIGN CONTRIBUTION DISCLOSURE FORM

The Bidder shall submit a completed Campaign Contribution Disclosure Form Pursuant to Chapter 81, Laws of 2006.

### COMMERCIAL WARRANTY

The Bidder agrees that the products or services furnished under a Purchase Order shall be covered by the most favorable commercial warranties that the Bidder gives to any customer for such products or services. And that the rights and remedies provided therein shall extend to the City and are in addition to and do not limit any rights afforded to the City by any other clause of its Purchase Order. Bidder agrees not to disclaim warranties of fitness for any particular purpose or merchantability.

Furthermore, Bidder agrees that its warranty for all products furnished under a Purchase Order pursuant to this Call for Bids shall be for a period of one year following the installation of said products by others. Also a receipt of a notice by the City's Engineer the products have been installed correctly and have been demonstrated to be capable of performing their intended function.

### SPECIAL NOTICE

To preclude possible errors and/or misinterpretations, bid prices must be affixed in ink or typewritten legibly. Enclose one (1) original and two (2) copies of Bid documents.

### DEFAULT

The City reserves the right to cancel all or any part of an order without cost to the City if the Bidder fails to meet the provisions of the City's Purchase Order or the product specifications and to hold the Bidder liable for any excess costs occasioned due to the Bidder's default. The Bidder shall not be liable for any excess costs if failure to perform on an order arises out of cause beyond the control and without fault or negligence of the Bidder. Such causes include, but are not restricted to, acts of God or public enemy; acts of State or Federal Government; fires, floods, epidemics, quarantine restrictions, strikes, embargoes, unusually severe weather, or defaults of subcontractors. Due to any of the above unless the City shall determine that the supplies or services to be furnished by the subcontractor are obtainable from other sources in the City in this paragraph shall not be exclusive and are in addition to any other rights now being provided by law.

### BID PROTESTS

If any Bidder is of the opinion that the specifications as written preclude him/her from submitting a bid. His/her opinion should be made known to the Department involved in this bid request at least twelve (12) days prior to the scheduled bid opening date with a copy forwarded to the Finance Department. Bid protests will not be considered from parties which do not also furnish satisfactory documentation with their protest that their proposed system fully meets the functional intent of the TECHNICAL SPECIFICATIONS which accompany a Call for Bids.

## **NON-EXCLUSION**

Specifications of the bid request are not meant to exclude any Bidder or Manufacturer. Where a brand name or equal is indicated, it is for the purpose of describing the standard of quality, performance and characteristics desired and is not intended to restrict competition. "No Substitute" specifications may be authorized, only if required to match existing equipment.

If any Bidder is of the opinion that the specifications as written preclude him/her from submitting a bid. His/her opinion should be made known to the Department involved in this bid request at least five (5) days prior to the scheduled bid opening date; with a copy forwarded to the Finance Department.

Brand names and numbers are for reference only and equivalents will be considered. If bidding "EQUIVALENT" Bidder must be prepared to furnish complete data upon request, preferably with the bid to avoid awarding delay.

## **CONTRACT**

When the City issues a Purchase Order in response to an awarded Bid a binding contract is created (unless a specified contract has been created).

## **TERMINATION**

This Price Agreement may be terminated by either party upon signing a written notice to the other party at least thirty (30) days in advance of the date of termination. Notice of termination of this Price Agreement shall not affect any outstanding orders.

## **TAXES**

Bidder must pay all applicable taxes.

## **NOTE:**

If bidder is from outside the City of Las Vegas, the successful bidder must pay Gross Receipts in the City of Las Vegas.

**BIDDER INFORMATION**

BIDDER: \_\_\_\_\_

AUTHORIZED AGENT: \_\_\_\_\_

ADDRESS: \_\_\_\_\_

TELEPHONE NUMBER (\_\_\_\_\_) \_\_\_\_\_

FAX NUMBER (\_\_\_\_\_) \_\_\_\_\_

DELIVERY: \_\_\_\_\_

STATE PURCHASING RESIDENT CERTIFICATION NO.: \_\_\_\_\_

NEW MEXICO CONTRACTORS LICENSE NO.: \_\_\_\_\_

BID ITEM (S): NATURAL GAS INVENTORY SUPPLY

**ITEM (S) UNDER THIS BID ARE TO BE F.O.B. LAS VEGAS, NEW MEXICO 87701. THE CITY OF LAS VEGAS RESERVES THE RIGHT REJECT ANY OR ALL BIDS AND TO WAIVE ANY TECHINCAL IRREGULARITY IN THE FORM OF THE BID.**

**AFFIDAVIT FOR FILING WITH COMPETITIVE BID**

STATE OF \_\_\_\_\_ }

COUNTY OF \_\_\_\_\_ }

I \_\_\_\_\_, of lawful age, being of first duly sworn in oath, say that I am the agent authorized by the bidder to submit the attached bid. Affiant further states that the bidder has not been a party to any collusion among bidders in restraint of freedom of competition by agreement to bid at a fixed price or to refrain from bidding; or with any city official or employee as to the terms of said prospective contract, or any other terms of said prospective contract; or in any discussion between bidders with any city official concerning an exchange of money or any other thing of value for special consideration in the letting of a contract.

Subscribed and sworn to before me, this \_\_\_\_\_ day of \_\_\_\_\_, 20\_\_\_\_.

\_\_\_\_\_  
Signature

(SEAL)

\_\_\_\_\_  
Notary Public Signature  
My Commission Expires: \_\_\_\_\_

**CITY OF LAS VGAS**

**BID ITEM (S): NATURAL GAS INVENTORY SUPPLY**

---

<b>ITEM</b>	<b>DESCRIPTION</b>	<b>UNIT PRICE</b>
1.	Roots-Series B3 Line Mount Meter's 11-M175 (TC)-4" Flange 8 Bolt	_____
2.	American AL-1400 Diaphragm Meter 2" NPT 100 PSIG MAOP	_____
3.	American AL-800 Diaphragm Meter 45LT 1-1 1/2" NPT	_____
4.	American AL-2300 Diaphragm Meter 4" flanged connection 100psig MAOP	_____
5.	American AL-5000 Diaphragm Meter 4" flanged connection 100 psig MAOP	_____
6.	American 425 Natural Gas Meter	_____
7.	American AC 630 Natural Gas Meter	_____
8.	American AL-1000 Diaphragm meter 45LT, 1-1 1/2" NPT	_____
9.	750/1600 Natural Gas Meter w/max working pressure 100lb – w/standard connections 45LT	_____
10.	1000 Natural Gas Meter working pressure 25lb	_____
11.	Model-441-57S Self-Operated Low and High Pressure Large Capacity Regulators 4" 8 Bolt Flange ASME	_____
12.	Model-046-2Field High Pressure Service Regulator 1"x1"	_____
13.	275 TC Meter w/1" connections, galvanized. One side Insulated. Or equal	_____
14.	2" x 2" 243-8-2 regulator IRV, 6" to 14" spring, w/3/8" orifice. Or equal	_____
15.	2" x 2" 243-HP Regulator, IRV w/1/2" orifice. 3 PSI to 10 PSI or equal to	_____
16.	1" x 1" 143-80-2 regulator. IRV 6" to 14" spring. 3/8" orifice. Or equal	_____
17.	3/4" x 3/4" Model 496 regulator. IRV 6" to 14" spring. 1/8" orifice. Or equal	_____
18.	1" x 1" 143-80-2 HP regulator IRV 2 -6 PSI, 3/8" orifice. Or equal	_____
19.	1" x 1" Model 496 regulator IRV 6" to 14" spring. 1/8" orifice. Or equal	_____



20. 2 x 2-243-RPC-B Regulator. ½" orifice – 10 PSIG-35 PSI.  
Or equal
21. 45LT x 1 ¼" galvanized gas meter connection Per Set
22. 45LT x 1 ½" galvanized insulated gas meter connection.  
Per Set Insulated
23. 20LT x 1" M.P.T. galvanized swivel & nut Per Set -  
Insulated
24. ¾" Polyethylene Gas Pipe Performance Pipe PE 3408--  
A.S.T.M-D-2513 or equal
25. 1" Polyethylene Gas Pipe Performance Pipe PE 3408--  
A.S.T.M-D-2513 or equal
26. 1 ¼" Polyethylene Gas Pipe Performance Pipe PE 3408--  
A.S.T.M-D-2513 or equal
27. 2" Polyethylene Gas Pipe Performance Pipe PE 3408 –  
A.S.T.M-D-2513 or equal
28. 4" Polyethylene Gas Pipe Performance Pipe PE 3408--  
A.S.T.M-D-2513 or equal
29. 4" IPS Transition fitting steel weld end x PE 3408 butt  
connection– A.S.T.M-D-2513
30. 2" IPS Transition fitting steel weld end x PE 3408 Butt  
connection– A.S.T.M-D-2513
31. 1" IPS Transition fitting steel weld end x PE 3408 Butt  
connection– A.S.T.M-D-2513
32. PQ-11-Bypass Tee 2" IPS main x 2" IPS Abandonment  
outlet Part#-5662-17-1017-00 Continental Industries
33. 4" PE 3408 butt fusion connection cap– A.S.T.M-D-2513
34. 2" PE 3408 butt fusion connection cap– A.S.T.M-D-2513
35. 1" PE 3408 butt fusion connection cap– A.S.T.M-D-2513
36. 4"x 2 PE 3408 butt fusion connection – A.S.T.M-D-2513  
Reducer
37. 2" x 1" PE 3408 butt fusion connection – A.S.T.M-D-2513  
Reducer

38. 1 1/4" x 1" PE 3408 butt fusion connection Reducer

39. 1" x 3/4" PE 3408 butt fusion connection Reducer

40. 1 1/4" x 2" PE 3408 butt fusion connection Reducer

41. 1 1/4" PE 3408 butt fusion connection cap

42. 2" PE 3408 butt fusion connection Tee – A.S.T.M-D-2513 Tee

43. 4" PE 3408 butt fusion connection Tee – A.S.T.M-D-2513 Tee

44. 1" PE 3408 butt fusion connection 90 degree elbow-A.S.T.M-D2513

45. 1 1/4" PE 3408 butt fusion connection 90 degree elbow– A.S.T.M-D-2513

46. 1" Butt fusion connection Tee– A.S.T.M-D-2513

47. 2" PE 3408 butt fusion connection 90 degree elbow– A.S.T.M-D-2513

48. 4" PE 3408 butt fusion connection 90 degree elbow– A.S.T.M-D-2513

49. 2" x 1" PE tapping tee assembly– A.S.T.M-D-2513

50. 2" x 2" PE tapping tee assembly– A.S.T.M-D-2513

51. 4" x 1" PE tapping tee assembly

52. 4" x 2" PE tapping tee assembly

Note: Tapping tee assemblies to be adaptable to performance pipe PE 3408 fusion connections or equal

53. Anodeless service riser. 1" x1" By pass -SDR-11-P.E. 3408 R.W. Lyall or equal– A.S.T.M-D-2513

54. Anodeless service riser. 1" IPS x 1" NPT-SDR-11-P.E. 3408 R.W. Lyall or equal– A.S.T.M-D-2513

55. Anodeless service riser. 2" NPT x 2" IPS SDR11-P.E. 3408 R.W. Lyall or equal– A.S.T.M-D-2513

56. 2" PE 3408 Valve– A.S.T.M-D-2513

57. 4" PE 3408 Valve– A.S.T.M-D-2513

- 58. 2" x 2"-175 Mueller Lubeseal in line pvc valve \_\_\_\_\_
- 59. 2" x 1" gas service saddle PVC w/compression outlet.  
Continental #5361-1014 or equal \_\_\_\_\_
- 60. 1 ¼" pipe joint clamp MB Skinner #089862 or equal \_\_\_\_\_
- 61. 1 1/2" pipe joint clamp MB Skinner #089861 or equal \_\_\_\_\_
- 62. 2" pipe joint clamp MB Skinner #089860 or equal \_\_\_\_\_
- 63. 4" line stopper fitting 250 P.S.I. Mueller #H17190 or equal \_\_\_\_\_
- 64. 2" line stopper fitting 250 P.S.I. Mueller #H17190 or equal \_\_\_\_\_
- 65. 2" plug valve, lubricated w/flange connection. CI for gas \_\_\_\_\_
- 66. 2" plug valve, lubricated w/threaded ends. CI for gas \_\_\_\_\_
- 67. 4" plug valve, lubricated w/flange ends. CI for gas \_\_\_\_\_
- 68. Meter barrel lock. Mueller #504979 or equal \_\_\_\_\_
- 69. 3" line stoppers fittings 250. P.S.I. Mueller \_\_\_\_\_
- 70. ¾" Mueller steel auto perf tee or equal \_\_\_\_\_
- 71. 1" Mueller steel autopperf tee or equal \_\_\_\_\_
- 72. 3/4" IPS x 1" IPS transition Punch Tee \_\_\_\_\_
- 73. Thermoweld cartridge #15 CP Box of 20 \_\_\_\_\_
- 74. 2" PVC to PVC compression for gas \_\_\_\_\_
- 75. 1" PVC T PVC compression coupling for gas \_\_\_\_\_
- 76. Lock wing iron body meter stop Inlet: 1" inside I.P. thread  
Outlet: 1" insulated union coupling w/inside I.P. thread.  
Finish: black or brass. 175 P.S.I. \_\_\_\_\_
- 77. Lock wing iron body meter stop Inlet: 1" inside I.P. thread  
Outlet: 1" inside I.P. thread Finish: Black or brass 175 P.S.I. \_\_\_\_\_
- 78. Tinker & Razor Half Cell reference electrodes  
Model-6-B-cucu 504 Half cell 1/ ¼" x 6" \_\_\_\_\_
- 79. CuCu-504 crystals 1lb. 3ox bottle P#04-9011 \_\_\_\_\_
- 80. Ceramic Tip Assembly- Pointed  
P#118-027 \_\_\_\_\_

- 81. 2 x 1 -- PE 4710 HDPE Tapping Tee w/Rectangular Base & Model EFVEB-BB7YY00 \_\_\_\_\_
- 82. 4 x 1 --PE-4710-HDPE Tapping Tee w/Rectangular Base & model EFVEB-BB7YY00 Excess Flow Valve \_\_\_\_\_
- 83. Excess Flow Valve Model B -- w/minimum Trip Point of 525SCFit @ 10 P.S.I. Stick Type \_\_\_\_\_
- 84. 2" PVC to 2" IPS Transition Fitting \_\_\_\_\_
- 85. Valve Boxes Plastic for 2" to 3" FP Valve-31 \_\_\_\_\_
- 86. Valve Supports for 2" Valve \_\_\_\_\_
- 87. Valve Supports for 4" Valve \_\_\_\_\_
- 88. Trenton wax tape 6"x9' (16 rolls per case) \_\_\_\_\_
- 89. Trenton wax tape primer brown (4 gal per case) \_\_\_\_\_
- 90. Barricade tape Gas Line Below yellow & black (8 rolls per case) \_\_\_\_\_
- 91. #12 Solid BC .030 w/yellow tracer wire 500 ft (500 ft rolls/ 4 rolls per case) \_\_\_\_\_
- 92. Harveys 10 mil Pipe Wrap 2" x 100' (24 per case) \_\_\_\_\_
- 93. Magnesium--Anode -- HC -- Potential -- 32lb \_\_\_\_\_
- 94. Magnesium -- Anodes -- 5lbs H.C \_\_\_\_\_
- 95. Magnesium-Anodes-9lb H.C. \_\_\_\_\_
- 96. Magnesium -- Anodes -- 17lbs H.C \_\_\_\_\_
- 97. Magnesium -- Anodes -- 50lbs H.C \_\_\_\_\_
- 98. Leak Detection Low temp Leak locator \_\_\_\_\_
- 99. White/Yellow line locate paint, inverted marking paint \_\_\_\_\_

Note:

1. Bid prices to remain firm for a period of one (1) year after date of bid awardment.
2. All items to be F.O.B. City of Las Vegas, Utility Center, 905 12<sup>th</sup> Street Las Vegas, NM 87701.
3. Unit Price Includes Freight and Sales Tax on taxable item on unit bid.
4. The City of Las Vegas reserves the right to award bid on an individual item basis.
5. Item 13, R275 meter, maximum allowable operating pressure to be 5 PSI. To be equipped with 1" Connection

## CAMPAIGN CONTRIBUTION DISCLOSURE FORM

Pursuant to Chapter 81, Laws of 2006, any prospective contractor seeking to enter into a contract with any state agency or local public body must file this form with that state agency or local public body. The prospective contractor must disclose whether they, a family member or a representative of the prospective contractor has made a campaign contribution to an applicable public official of the state or a local public body during the two years prior to the date on which the contractor submits a proposal or, in the case of a sole source or small purchase contract, the two years prior to the date the contractor signs the contract, if the aggregate total of contributions given by the prospective contractor, a family member or a representative of the prospective contractor to the public official exceeds two hundred and fifty dollars (\$250) over the two year period.

**THIS FORM MUST BE FILED BY ANY PROSPECTIVE CONTRACTOR WHETHER OR NOT THEY, THEIR FAMILY MEMBER, OR THEIR REPRESENTATIVE HAS MADE ANY CONTRIBUTIONS SUBJECT TO DISCLOSURE.**

The following definitions apply:

"Applicable public official" means a person elected to an office or a person appointed to complete a term of an elected office, who has the authority to award or influence the award of the contract for which the prospective contractor is submitting a competitive sealed proposal or who has the authority to negotiate a sole source or small purchase contract that may be awarded without submission of a sealed competitive proposal.

"Campaign Contribution" means a gift, subscription, loan, advance or deposit of money or other thing of value, including the estimated value of an in-kind contribution, that is made to or received by an applicable public official or any person authorized to raise, collect or expend contributions on that official's behalf for the purpose of electing the official to either statewide or local office. "Campaign Contribution" includes the payment of a debt incurred in an election campaign, but does not include the value of services provided without compensation or unreimbursed travel or other personal expenses of individuals who volunteer a portion or all of their time on behalf of a candidate or political committee, nor does it include the administrative or solicitation expenses of a political committee that are paid by an organization that sponsors the committee.

"Contract" means any agreement for the procurement of items of tangible personal property, services, professional services, or construction.

"Family member" means spouse, father, mother, child, father-in-law, mother-in-law, daughter-in-law or son-in-law.

"Pendency of the procurement process" means the time period commencing with the public notice of the request for proposals and ending with the award of the contract or the cancellation of the request for proposals.

"Person" means any corporation, partnership, individual, joint venture, association or any other private legal entity.

"Prospective contractor" means a person who is subject to the competitive sealed

proposal process set forth in the Procurement Code or is not required to submit a competitive sealed proposal because that person qualifies for a sole source or a small purchase contract.

**"Representative of a prospective contractor"** means an officer or director of a corporation, a member or manager of a limited liability corporation, a partner of a partnership or a trustee of a trust of the prospective contractor.

**DISCLOSURE OF CONTRIBUTIONS:**

Contribution Made By: \_\_\_\_\_

Relation to Prospective Contractor: \_\_\_\_\_

Name of Applicable Public Official: \_\_\_\_\_

Date Contribution(s) Made: \_\_\_\_\_

Amount(s) of Contribution(s) \_\_\_\_\_

Nature of Contribution(s) \_\_\_\_\_

Purpose of Contribution(s) \_\_\_\_\_

(The above fields are unlimited in size) \_\_\_\_\_

\_\_\_\_\_  
Signature

\_\_\_\_\_  
Date

\_\_\_\_\_  
Title (position)

-OR-

**NO CONTRIBUTIONS IN THE AGGREGATE TOTAL OVER TWO HUNDRED FIFTY DOLLARS (\$250) WERE MADE to an applicable public official by me, a family member or representative.**

\_\_\_\_\_  
Signature

\_\_\_\_\_  
Date

\_\_\_\_\_  
Title (Position)

**REQUEST FOR BIDS**

The City of Las Vegas, New Mexico will open Sealed Bids at 2:00 p.m. Dec 1, 2016 at 3:00 pm the City Council Chambers, 1700 North Grand Avenue, Las Vegas, New Mexico, or other designated area at the City Offices; ON THE FOLLOWING:

**NATURAL GAS INVENTORY SUPPLIES**

The BIDDING FORMS AND TECHNICAL SPECIFICATIONS may be examined at the following location: 1700 NORTH GRAND, LAS VEGAS, NM

Copies of the BIDDING FORMS AND TECHNICAL SPECIFICATIONS may be obtained at the office of: 1700 NORTH GRAND, LAS VEGAS, NM

Mailed Bids should be addressed to the City Clerk, 1700 N. Grand Ave., Las Vegas, New Mexico 87701; with the envelope marked: NATURAL GAS INVENTORY SUPPLIES, Opening No. 2017-12; on the lower left-hand corner of the submitted envelope. It shall be the responsibility of the bidder to see that their bid is delivered to the City Clerk by the date and time set for the bid request. If the mail or delivery of bid request is delayed beyond the opening date and time, bid thus delayed will not be considered. A public opening will be held and any bidder or their authorized representative is invited to attend.

The City of Las Vegas reserves the right to reject any/or all bids submitted.

CITY OF LAS VEGAS,

Richard R. Trujillo  
RICHARD TRUJILLO, CITY MANAGER

H. Chico Gallegos  
H. CHICO GALLEGOS, CITY ATTORNEY

Cassandra Fresquez  
CASANDRA FRESQUEZ, CITY CLERK

Ann M. Gallegos  
ANN M. GALLEGOS, FINANCE DIRECTOR

Helen Vigil  
HELEN VIGIL, PURCHASING OFFICER

Opening No. 2017-12

Date Issued: 11/2/2016

Date Issued: Published:

Albuquerque Journal Nov 16, 2016  
Las Vegas Optic Nov 16, 2016  
City website: [www.lasvegasnm.gov](http://www.lasvegasnm.gov)

RECEIVED  
DEC 01 2016

2.0e CITY OF LAS VEGAS

## STANDARD BID CLAUSES

### AWARDED BID

Awarding of Bid shall be made to the responsible Bidder whose Bid meets the required specifications. The City of Las Vegas (City) reserves the right to reject or accept any of all Bid specifications and to waive any insubstantial irregularity in the form of the Bid.

The City of Las Vegas may make multiple awards of the bid, to those bidding in law enforcement related services. The City Reserves the right to award the bid to the most advantageous Bidder to the City.

### TIMETABLE

Bids pursuant to this request must be received at the City Clerk's Office at 1700 North Grand Avenue, Las Vegas, New Mexico, on or before 2:00 pm, Dec 1, 2016 at which time all bids received will be opened. An opening will occur at the City's Council Chambers or other designated area at the City Offices. Awarding of Bid is projected for \_\_\_\_\_, 20\_\_\_\_. The successful Bidder will be notified by mail.

### ENVELOPES

Sealed Bid envelopes shall be clearly marked on the lower left-hand corner, identified by the Bid Name and Opening Number. Failure to comply with this requirement may result in the rejection of your submitted Bid. Enclose one (1) original and two (2) copies of Bid.

### BRIBERY AND KICKBACK

The Procurement Code of New Mexico; (Section 13-1-28 through 13-1-99 N.M.S.A. 1978), impose a third degree felony penalty for bribery of a public official or public employee. In addition the New Mexico Criminal Statutes (Section 30-4-1, N.M.S.A. 1978): state that it is a third degree felony to commit the offense of demanding or receiving a bribe by a public official of public employee. And (Section 30-24-2, N.M.S.A. 1978): it is a fourth degree felony to commit the offense of soliciting or receiving illegal kickbacks. Also (Section 30-41-1 through 30-41-3, N.M.S.A. 1978): states that it is a fourth degree felony to commit the offense of offering or paying illegal kickbacks.

### NON-COLLUSION

In signing their Bid and Affidavit, the Bidder certifies that he/she has not, either directly or indirectly entered into action of restraint of free competition, in the connection with the submitted bid.

### RESPONSIBILITY OF BIDDER

At all times it shall be the responsibility of the Bidder to see their bid is delivered to the City Clerk by the Date and Time scheduled for opening. If the mail or delivery of said Bid is delayed beyond the scheduled opening date and time set, this bid will not be considered.



**CLARIFICATION OF BID**

Bidder requiring clarification or interpretation of Bid specifications shall make a written request to the Department involved in this bid request at least five (5) days prior to the scheduled bid opening date with a copy forwarded to the Finance Department. Any interpretation, corrections or changes of said Bid Specifications, Opening Date, or Time Change will be made by Addendum only. Interpretations, Corrections or changes of said bid made in any other manner will not be binding and the Bidder shall not rely upon such interpretation, corrections and changes.

**MODIFICATION OF BID**

Bids may be withdrawn upon receipt of written request prior to the scheduled bid opening for the purpose of making any corrections or changes. Such corrections must be properly identified and signed or initialed by the Bidder. Resubmission must be prior to the scheduled bid opening time in order to be considered. After bid opening, no price modifications of submitted bids or other provisions shall be permitted.

**WITHDRAWAL OF BID**

A low Bidder alleging a material mistake of fact, after bids have been opened may request their bid be withdrawn upon receipt of a written request to the Finance Department prior to the scheduled awarding date.

**INSPECTION**

Final inspection and acceptance will be made at the City's discretion. Products rejected for nonconformance with the specifications shall be removed by the Bidder; at his/her risk and expense promptly after notice of rejection.

**FEDERAL TAX IDENTIFICATION NUMBER**

Pursuant to IRS requirements, Bidder shall provide their Federal Tax ID Number if Bidder is incorporated. If Bidder is a sole proprietorship or partnership then they shall provide their Social Security Number.

FEDERAL TAX ID NUMBER: 91-1923788  
SOCIAL SECURITY NUMBER: \_\_\_\_\_

**NEW MEXICO TAX IDENTIFICATION NUMBER**

Payment may be withheld under (Section 7-10-5, N.M.S.A. 1978) if you are subject to New Mexico Gross Receipts Tax and have not registered for a New Mexico (CRS) Tax Identification Number. Contact the New Mexico Taxation & Revenue Department at (505) 827-0700 for registering instructions.

NEW MEXICO TAX IDENTIFICATION NO. (CRS): 03-333732-00-2

## CAMPAIGN CONTRIBUTION DISCLOSURE FORM

The Bidder shall submit a completed Campaign Contribution Disclosure Form Pursuant to Chapter 81, Laws of 2006.

### COMMERCIAL WARRANTY

The Bidder agrees that the products or services furnished under a Purchase Order shall be covered by the most favorable commercial warranties that the Bidder gives to any customer for such products or services. And that the rights and remedies provided therein shall extend to the City and are in addition to and do not limit any rights afforded to the City by any other clause of its Purchase Order. Bidder agrees not to disclaim warranties of fitness for any particular purpose or merchantability.

Furthermore, Bidder agrees that its warranty for all products furnished under a Purchase Order pursuant to this Call for Bids shall be for a period of one year following the installation of said products by others. Also a receipt of a notice by the City's Engineer the products have been installed correctly and have been demonstrated to be capable of performing their intended function.

### SPECIAL NOTICE

To preclude possible errors and/or misinterpretations, bid prices must be affixed in ink or typewritten legibly. Enclose one (1) original and two (2) copies of Bid documents.

### DEFAULT

The City reserves the right to cancel all or any part of an order without cost to the City if the Bidder fails to meet the provisions of the City's Purchase Order or the product specifications and to hold the Bidder liable for any excess costs occasioned due to the Bidder's default. The Bidder shall not be liable for any excess costs if failure to perform on an order arises out of cause beyond the control and without fault or negligence of the Bidder. Such causes include, but are not restricted to, acts of God or public enemy; acts of State or Federal Government; fires, floods, epidemics, quarantine restrictions, strikes, embargoes, unusually severe weather, or defaults of subcontractors. Due to any of the above unless the City shall determine that the supplies or services to be furnished by the subcontractor are obtainable from other sources in the City in this paragraph shall not be exclusive and are in addition to any other rights now being provided by law.

### BID PROTESTS

If any Bidder is of the opinion that the specifications as written preclude him/her from submitting a bid. His/her opinion should be made known to the Department involved in this bid request at least twelve (12) days prior to the scheduled bid opening date with a copy forwarded to the Finance Department. Bid protests will not be considered from parties which do not also furnish satisfactory documentation with their protest that their proposed system fully meets the functional intent of the TECHNICAL SPECIFICATIONS which accompany a Call for Bids.

## NON-EXCLUSION

Specifications of the bid request are not meant to exclude any Bidder or Manufacturer. Where a brand name or equal is indicated, it is for the purpose of describing the standard of quality, performance and characteristics desired and is not intended to restrict competition. "No Substitute" specifications may be authorized, only if required to match existing equipment.

If any Bidder is of the opinion that the specifications as written preclude him/her from submitting a bid. His/her opinion should be made known to the Department involved in this bid request at least five (5) days prior to the scheduled bid opening date; with a copy forwarded to the Finance Department.

Brand names and numbers are for reference only and equivalents will be considered. If bidding "EQUIVALENT" Bidder must be prepared to furnish complete data upon request, preferably with the bid to avoid awarding delay.

## CONTRACT

When the City issues a Purchase Order in response to an awarded Bid a binding contract is created (unless a specified contract has been created).

## TERMINATION

This Price Agreement may be terminated by either party upon signing a written notice to the other party at least thirty (30) days in advance of the date of termination. Notice of termination of this Price Agreement shall not affect any outstanding orders.

## TAXES

Bidder must pay all applicable taxes.

## NOTE:

If bidder is from outside the City of Las Vegas, the successful bidder must pay Gross Receipts in the City of Las Vegas.

BIDDER INFORMATION

BIDDER: KOONS GAS MEASUREMENT

AUTHORIZED AGENT: Mark Abshire

ADDRESS: 10934 E 55TH PLACE, TULSA, OK 74147

TELEPHONE NUMBER (918) 794-9494

FAX NUMBER (918) 794-5575

DELIVERY: \_\_\_\_\_

STATE PURCHASING RESIDENT CERTIFICATION NO.: \_\_\_\_\_

NEW MEXICO CONTRACTORS LICENSE NO.: \_\_\_\_\_

BID ITEM (S): NATURAL GAS INVENTORY SUPPLY

ITEM (S) UNDER THIS BID ARE TO BE F.O.B. LAS VEGAS, NEW MEXICO 87701. THE CITY OF LAS VEGAS RESERVES THE RIGHT REJECT ANY OR ALL BIDS AND TO WAIVE ANY TECHNICAL IRREGULARITY IN THE FORM OF THE BID.

AFFIDAVIT FOR FILING WITH COMPETITIVE BID

STATE OF Oklahoma

COUNTY OF Tulsa

I Mark Abshire, of lawful age, being of first duly sworn in oath, say that I am the agent authorized by the bidder to submit the attached bid. Affiant further states that the bidder has not been a party to any collusion among bidders in restraint of freedom of competition by agreement to bid at a fixed price or to refrain from bidding; or with any city official or employee as to the terms of said prospective contract, or any other terms of said prospective contract; or in any discussion between bidders with any city official concerning an exchange of money or any other thing of value for special consideration in the letting of a contract.

Subscribed and sworn to before me, this 29 day of Nov, 2010.

[Signature]  
Signature

[Signature]  
Notary Public Signature

My Commission Expires: 03.26.18

(SEAL)



City of Las Vegas		Attachment to Bid opening #		2017-12									
Mfg	Model	Description			Warranty	Price Each	New Rotary Equivalent	Description	Price Each	Warranty			
American	AL1400	Diaphragm METER 2" NPT 100 PSIG MAOP	Refurbished		2 Year warranty	\$1,595.00	15C175CTR	15C ROOTS METER, CTR, 2" FF, 175 PSI MAOP	\$1,311.00	1 Year Warranty			
American	AL800	Diaphragm METER 45LT 1-1/2 NPT	Refurbished		2 Year warranty	\$995.00	D1000	1M ROOTS METER, LCD, 45LT, 25 PSI MAOP	\$1,198.00	2 Year Warranty			
American	AL2300	Diaphragm Meter 4" Flanged connection 100 psig MAOP	Refurbished		2 Year warranty	\$2,600.00	3M175CTR	3M ROOTS METER, CTR, 2" FF, 175 PSI MAOP	\$1,567.00	1 Year Warranty			
American	AL5000	Diaphragm Meter 4" Flanged connection 100 psig MAOP	Refurbished		2 Year warranty	\$3,425.00	5M175CTR	5M ROOTS METER, CTR, 3" FF, 175 PSI MAOP	\$2,084.00	1 Year Warranty			
American	AL425	Natural Gas Meter	Refurbished		2 Year warranty	\$290.00	D800	8C ROOTS METER, LCD, 30 LT, 175 PSI MAOP	\$1,198.00	2 Year Warranty			
American	AC630	Natural Gas Meter	Refurbished		2 Year warranty	\$475.00	D800	8C ROOTS METER, LCD, 30 LT, 175 PSI MAOP	\$1,198.00	2 Year Warranty			
American	AL1000	Diaphragm METER 45LT 1-1/2 NPT	Refurbished		2 Year warranty	\$1,050.00	D1000	1M ROOTS METER, LCD, 45LT, 25 PSI MAOP	\$1,198.00	2 Year Warranty			
Sensus	R1600	Diaphragm Meter w/max working pressures 100lb 45LT connection	Refurbished		2 Year warranty	\$1,050.00	D1000	1M ROOTS METER, LCD, 45LT, 25 PSI MAOP	\$1,198.00	2 Year Warranty			
Sensus	R1000	natural gas meter working pressure 25 lb	Refurbished		2 Year warranty	\$1,050.00	D1000	1M ROOTS METER, LCD, 45LT, 25 PSI MAOP	\$1,198.00	2 Year Warranty			
Sensus	R275	TC Meter w/1" connection galvanized. One side insulated. Or equal	Refurbished		2 Year warranty	\$74.50							

**CITY OF LAS VEGAS**

**BID ITEM (S): NATURAL GAS INVENTORY SUPPLY**

---



---

ITEM	DESCRIPTION	UNIT PRICE
1.	Roots-Series B3 Line Mount Meter's 11-M175 (TC)-4" Flange 8 Bolt	<u># 3741<sup>00</sup></u>
2.	American AL-1400 Diaphragm Meter 2" NPT 100 PSIG MAOP	<u>See Attachment</u>
3.	American AL-800 Diaphragm Meter 45LT 1-1/2" NPT	<u>See Attachment</u>
4.	American AL-2300 Diaphragm Meter 4" flanged connection 100psig MAOP	<u>See Attachment</u>
5.	American AL-5000 Diaphragm Meter 4" flanged connection 100 psig MAOP	<u>See Attachment</u>
6.	American 425 Natural Gas Meter	<u>See Attachment</u>
7.	American AC 630 Natural Gas Meter	<u>See Attachment</u>
8.	American AL-1000 Diaphragm meter 45LT, 1-1 1/2" NPT	<u>See Attachment</u>
9.	750/1600 Natural Gas Meter w/max working pressure 100lb -- w/standard connections 45LT	<u>See Attachment</u>
10.	1000 Natural Gas Meter working pressure 25lb	<u>See Attachment</u>
11.	Model-441-57S Self-Operated Low and High Pressure Large Capacity Regulators 4" 8 Bolt Flange ASME	_____
12.	Model-046-2Field High Pressure Service Regulator 1"x1"	_____
13.	275 TC Meter w/1" connections, galvanized. One side insulated. Or equal	<u>See Attachment</u>
14.	2" x 2" 243-8-2 regulator IRV, 6" to 14" spring, w/3/8" orifice. Or equal	_____
15.	2" x 2" 243-HP Regulator, IRV w/1/2" orifice. 3 PSI to 10 PSI or equal to	_____
16.	1" x 1" 143-80-2 regulator. IRV 6" to 14" spring. 3/8" orifice. Or equal	_____
17.	3/4" x 3/4" Model 496 regulator. IRV 6" to 14" spring. 1/8" orifice. Or equal	_____
18.	1" x 1" 143-80-2 HP regulator IRV 2-6 PSI, 3/8" orifice. Or equal	_____
19.	1" x 1" Model 496 regulator IRV 6" to 14" spring. 1/8" orifice. Or equal	_____

20. 2 x 2-243-RPC-B Regulator. 1/2" orifice - 10 PSIG-35 PSI.  
Or equal

21. 45LT x 1 1/4" galvanized gas meter connection Per Set

9.25 1 EA SWIVEL/NUT/  
GASKET

22. 45LT x 1 1/2" galvanized insulated gas meter connection.  
Per Set Insulated

9.75 1 EA INSULATED  
SWIVEL/NUT/  
GASKET

23. 20LT x 1" M.P.T. galvanized swivel & nut Per Set -  
Insulated

2.00 1 EA INSULATED  
SWIVEL/NUT/GASKET

24. 3/4" Polyethylene Gas Pipe Performance Pipe PE 3408-  
A.S.T.M-D-2513 or equal

25. 1" Polyethylene Gas Pipe Performance Pipe PE 3408-  
A.S.T.M-D-2513 or equal

26. 1 1/4" Polyethylene Gas Pipe Performance Pipe PE 3408-  
A.S.T.M-D-2513 or equal

27. 2" Polyethylene Gas Pipe Performance Pipe PE 3408 -  
A.S.T.M-D-2513 or equal

28. 4" Polyethylene Gas Pipe Performance Pipe PE 3408-  
A.S.T.M-D-2513 or equal

29. 4" IPS Transition fitting steel weld end x PE 3408 butt  
connection- A.S.T.M-D-2513

30. 2" IPS Transition fitting steel weld end x PE 3408 Butt  
connection- A.S.T.M-D-2513

31. 1" IPS Transition fitting steel weld end x PE 3408 Butt  
connection- A.S.T.M-D-2513

32. PQ-11-Bypass Tee 2" IPS main x 2" IPS Abandonment  
outlet Part#-5662-17-1017-00 Continental Industries

33. 4" PE 3408 butt fusion connection cap- A.S.T.M-D-2513

34. 2" PE 3408 butt fusion connection cap- A.S.T.M-D-2513

35. 1" PE 3408 butt fusion connection cap- A.S.T.M-D-2513

36. 4"x 2 PE 3408 butt fusion connection - A.S.T.M-D-2513  
Reducer

37. 2" x 1" PE 3408 butt fusion connection - A.S.T.M-D-2513  
Reducer

38. 1 1/4" x 1" PE 3408 butt fusion connection Reducer

39. 1" x 3/4" PE 3408 butt fusion connection Reducer

40. 1 1/4" x 2" PE 3408 butt fusion connection Reducer

41. 1 1/4" PE 3408 butt fusion connection cap

42. 2" PE 3408 butt fusion connection Tee – A.S.T.M-D-2513  
Tee

43. 4" PE 3408 butt fusion connection Tee – A.S.T.M-D-2513  
Tee

44. 1" PE 3408 butt fusion connection 90 degree  
elbow-A.S.T.M-D2513

45. 1 1/4" PE 3408 butt fusion connection 90 degree  
elbow– A.S.T.M-D-2513

46. 1" Butt fusion connection Tee– A.S.T.M-D-2513

47. 2" PE 3408 butt fusion connection 90 degree elbow–  
A.S.T.M-D-2513

48. 4" PE 3408 butt fusion connection 90 degree elbow–  
A.S.T.M-D-2513

49. 2" x 1" PE tapping tee assembly– A.S.T.M-D-2513

50. 2" x 2" PE tapping tee assembly– A.S.T.M-D-2513

51. 4" x 1" PE tapping tee assembly

52. 4" x 2" PE tapping tee assembly

Note: Tapping tee assemblies to be adaptable to performance pipe PE  
3408 fusion connections or equal

53. Anodeless service riser. 1" x1" By pass -SDR-11-P.E. 3408  
R.W. Lyall or equal– A.S.T.M-D-2513

54. Anodeless service riser. 1" IPS x 1" NPT-SDR-11-P.E.  
3408 R.W. Lyall or equal– A.S.T.M-D-2513

55. Anodeless service riser. 2" NPT x 2" IPS SDR11-P.E. 3408  
R.W. Lyall or equal– A.S.T.M-D-2513

56. 2" PE 3408 Valve– A.S.T.M-D-2513

57. 4" PE 3408 Valve– A.S.T.M-D-2513



- 58. 2" x 2"-175 Mueller Lubeseal in line pvc valve \_\_\_\_\_
- 59. 2" x 1" gas service saddle PVC w/compression outlet.  
Continental #5361-1014 or equal \_\_\_\_\_
- 60. 1 1/4" pipe joint clamp MB Skinner #089862 or equal \_\_\_\_\_
- 61. 1 1/2" pipe joint clamp MB Skinner #089861 or equal \_\_\_\_\_
- 62. 2" pipe joint clamp MB Skinner #089860 or equal \_\_\_\_\_
- 63. 4" line stopper fitting 250 P.S.I. Mueller #H17190 or equal \_\_\_\_\_
- 64. 2" line stopper fitting 250 P.S.I. Mueller #H17190 or equal \_\_\_\_\_
- 65. 2" plug valve, lubricated w/flange connection. CI for gas \_\_\_\_\_
- 66. 2" plug valve, lubricated w/threaded ends. CI for gas \_\_\_\_\_
- 67. 4" plug valve, lubricated w/flange ends. CI for gas \_\_\_\_\_
- 68. Meter barrel lock. Mueller #504979 or equal \_\_\_\_\_
- 69. 3" line stoppers fittings 250. P.S.I. Mueller \_\_\_\_\_
- 70. 3/4" Mueller steel auto perf tee or equal \_\_\_\_\_
- 71. 1" Mueller steel autoperf tee or equal \_\_\_\_\_
- 72. 3/4" IPS x 1" IPS transition Punch Tee \_\_\_\_\_
- 73. Thermoweld cartridge #15 CP Box of 20 40.00
- 74. 2" PVC to PVC compression for gas \_\_\_\_\_
- 75. 1" PVC T PVC compression coupling for gas \_\_\_\_\_
- 76. Lock wing iron body meter stop Inlet: 1" inside I.P. thread  
Outlet: 1" insulated union coupling w/inside I.P. thread.  
Finish: black or brass. 175 P.S.I. 50.21
- 77. Lock wing iron body meter stop Inlet: 1" inside I.P. thread  
Outlet: 1" Inside I.P. thread Finish: Black or brass 175 P.S.I. 21.75
- 78. Tinker & Razor Half Cell reference electrodes  
Model-6-B-cucu 504 Half cell 1/ 1/4" x 6" \_\_\_\_\_
- 79. CuCu-504 crystals 1lb. 3ox bottle P#04-9011 \_\_\_\_\_
- 80. Ceramic Tip Assembly- Pointed  
P#118-027 \_\_\_\_\_

81.	2 x 1 – PE 4710 HDPE Tapping Tee w/Rectangular Base & Model EFVEB-BB7YY00	_____
82.	4 x 1 –PE-4710-HDPE Tapping Tee w/Rectangular Base & model EFVEB-BB7YY00 Excess Flow Valve	_____
83.	Excess Flow Valve Model B – w/minimum Trip Point of 525SCFit @ 10 P.S.I. Stick Type	_____
84.	2" PVC to 2" IPS Transition Fitting	_____
85.	Valve Boxes Plastic for 2" to 3" FP Valve-31	_____
86.	Valve Supports for 2" Valve	_____
87.	Valve Supports for 4" Valve	_____
88.	Trenton wax tape 6"x9' (16 rolls per case)	_____
89.	Trenton wax tape primer brown (4 gal per case)	_____
90.	Barricade tape Gas Line Below yellow & black (8 rolls per case)	_____
91.	#12 Solid BC .030 w/yellow tracer wire 500 ft (500 ft rolls/ 4 rolls per case)	_____
92.	Harveys 10 mil Pipe Wrap 2" x 100' (24 per case)	_____
93.	Magnesium–Anode – HC – Potential – 32lb	<u>160.00</u>
94.	Magnesium – Anodes – 5lbs H.C	<u>31.07</u>
95.	Magnesium-Anodes-9lb H.C.	<u>50.25</u>
96.	Magnesium – Anodes – 17lbs H.C	<u>85.75</u>
97.	Magnesium – Anodes – 50lbs H.C	<u>235.75</u>
98.	Leak Detection Low temp Leak locator	_____
99.	White/Yellow line locate paint, inverted marking paint	_____

**Note:**

1. Bid prices to remain firm for a period of one (1) year after date of bid awardment.
2. All items to be F.O.B. City of Las Vegas, Utility Center, 905 12<sup>th</sup> Street Las Vegas, NM 87701.
3. Unit Price Includes Freight and Sales Tax on taxable item on unit bid.
4. The City of Las Vegas reserves the right to award bid on an individual item basis.
5. Item 13, R275 meter, maximum allowable operating pressure to be 5 PSI. To be equipped with 1" Connection

## CAMPAIGN CONTRIBUTION DISCLOSURE FORM

Pursuant to Chapter 81, Laws of 2006, any prospective contractor seeking to enter into a contract with any state agency or local public body must file this form with that state agency or local public body. The prospective contractor must disclose whether they, a family member or a representative of the prospective contractor has made a campaign contribution to an applicable public official of the state or a local public body during the two years prior to the date on which the contractor submits a proposal or, in the case of a sole source or small purchase contract, the two years prior to the date the contractor signs the contract, if the aggregate total of contributions given by the prospective contractor, a family member or a representative of the prospective contractor to the public official exceeds two hundred and fifty dollars (\$250) over the two year period.

**THIS FORM MUST BE FILED BY ANY PROSPECTIVE CONTRACTOR WHETHER OR NOT THEY, THEIR FAMILY MEMBER, OR THEIR REPRESENTATIVE HAS MADE ANY CONTRIBUTIONS SUBJECT TO DISCLOSURE.**

The following definitions apply:

"Applicable public official" means a person elected to an office or a person appointed to complete a term of an elected office, who has the authority to award or influence the award of the contract for which the prospective contractor is submitting a competitive sealed proposal or who has the authority to negotiate a sole source or small purchase contract that may be awarded without submission of a sealed competitive proposal.

"Campaign Contribution" means a gift, subscription, loan, advance or deposit of money or other thing of value, including the estimated value of an in-kind contribution, that is made to or received by an applicable public official or any person authorized to raise, collect or expend contributions on that official's behalf for the purpose of electing the official to either statewide or local office. "Campaign Contribution" includes the payment of a debt incurred in an election campaign, but does not include the value of services provided without compensation or unreimbursed travel or other personal expenses of individuals who volunteer a portion or all of their time on behalf of a candidate or political committee, nor does it include the administrative or solicitation expenses of a political committee that are paid by an organization that sponsors the committee.

"Contract" means any agreement for the procurement of items of tangible personal property, services, professional services, or construction.

"Family member" means spouse, father, mother, child, father-in-law, mother-in-law, daughter-in-law or son-in-law.

"Pendency of the procurement process" means the time period commencing with the public notice of the request for proposals and ending with the award of the contract or the cancellation of the request for proposals.

"Person" means any corporation, partnership, individual, joint venture, association or any other private legal entity.

"Prospective contractor" means a person who is subject to the competitive sealed

proposal process set forth in the Procurement Code or is not required to submit a competitive sealed proposal because that person qualifies for a sole source or a small purchase contract.

"Representative of a prospective contractor" means an officer or director of a corporation, a member or manager of a limited liability corporation, a partner of a partnership or a trustee of a trust of the prospective contractor.

**DISCLOSURE OF CONTRIBUTIONS:**

Contribution Made By: \_\_\_\_\_

Relation to Prospective Contractor: \_\_\_\_\_

Name of Applicable Public Official: \_\_\_\_\_

Date Contribution(s) Made: \_\_\_\_\_

Amount(s) of Contribution(s) \_\_\_\_\_

Nature of Contribution(s) \_\_\_\_\_

Purpose of Contribution(s) \_\_\_\_\_

(The above fields are unlimited in size) \_\_\_\_\_

\_\_\_\_\_  
Signature

\_\_\_\_\_  
Date

\_\_\_\_\_  
Title (position)

-OR-

**NO CONTRIBUTIONS IN THE AGGREGATE TOTAL OVER TWO HUNDRED FIFTY DOLLARS (\$250) WERE MADE to an applicable public official by me, a family member or representative.**

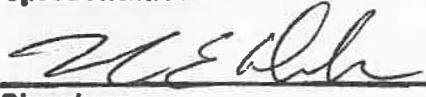
  
\_\_\_\_\_  
Signature

11/29/2016  
\_\_\_\_\_  
Date

Manager  
\_\_\_\_\_  
Title (Position)

REQUEST FOR BIDS

The City of Las Vegas, New Mexico will open Sealed Bids at 2:00 p.m., Dec 1, 2016 at 3:00 pm the City Council Chambers, 1700 North Grand Avenue, Las Vegas, New Mexico, or other designated area at the City Offices; ON THE FOLLOWING:

NATURAL GAS INVENTORY SUPPLIES

The BIDDING FORMS AND TECHNICAL SPECIFICATIONS may be examined at the following location: 1700 NORTH GRAND, LAS VEGAS, NM

Copies of the BIDDING FORMS AND TECHNICAL SPECIFICATIONS may be obtained at the office of : 1700 NORTH GRAND, LAS VEGAS, NM

Mailed Bids should be addressed to the City Clerk, 1700 N. Grand Ave., Las Vegas, New Mexico 87701; with the envelope marked: NATURAL GAS INVENTORY SUPPLIES, Opening No. 2017-12; on the lower left-hand corner of the submitted envelope. It shall be the responsibility of the bidder to see that their bid is delivered to the City Clerk by the date and time set for the bid request. If the mail or delivery of bid request is delayed beyond the opening date and time, bid thus delayed will not be considered. A public opening will be held and any bidder or their authorized representative is invited to attend.

The City of Las Vegas reserves the right to reject any/or all bids submitted.

CITY OF LAS VEGAS,

Richard R. Trujillo  
RICHARD TRUJILLO, CITY MANAGER

H. Chico Gallegos  
H. CHICO GALLEGOS, CITY ATTORNEY

Cassandra Fresquez  
CASANDRA FRESQUEZ, CITY CLERK

Ann M. Gallegos  
ANN M. GALLEGOS, FINANCE DIRECTOR

Helen Vigil  
HELEN VIGIL, PURCHASING OFFICER

Opening No. 2017-12

Date Issued: 11/2/2016

Date Issued: Published: Albuquerque Journal Nov 16, 2016  
Las Vegas Optic Nov 16, 2016  
City website: www.lasvegasnm.gov

RECEIVED  
DEC 01 2016

5:10 pm

CITY OF LAS VEGAS

## STANDARD BID CLAUSES

### AWARDED BID

Awarding of Bid shall be made to the responsible Bidder whose Bid meets the required specifications. The City of Las Vegas (City) reserves the right to reject or accept any of all Bid specifications and to waive any insubstantial irregularity in the form of the Bid.

The City of Las Vegas may make multiple awards of the bid, to those bidding in law enforcement related services. The City Reserves the right to award the bid to the most advantageous Bidder to the City.

### TIMETABLE

Bids pursuant to this request must be received at the City Clerk's Office at 1700 North Grand Avenue, Las Vegas, New Mexico, on or before 3:00 pm, Dec 1, 2016 at which time all bids received will be opened. An opening will occur at the City's Council Chambers or other designated area at the City Offices. Awarding of Bid is projected for \_\_\_\_\_, 20\_\_\_\_. The successful Bidder will be notified by mail.

### ENVELOPES

Sealed Bid envelopes shall be clearly marked on the lower left-hand corner, identified by the Bid Name and Opening Number. Failure to comply with this requirement may result in the rejection of your submitted Bid. Enclose one (1) original and two (2) copies of Bid.

### BRIBERY AND KICKBACK

The Procurement Code of New Mexico; (Section 13-1-28 through 13-1-99 N.M.S.A. 1978), impose a third degree felony penalty for bribery of a public official or public employee. In addition the New Mexico Criminal Statutes (Section 30-4-1, N.M.S.A. 1978): state that it is a third degree felony to commit the offense of demanding or receiving a bribe by a public official of public employee. And (Section 30-24-2, N.M.S.A. 1978): it is a fourth degree felony to commit the offense of soliciting or receiving illegal kickbacks. Also (Section 30-41-1 through 30-41-3, N.M.S.A. 1978): states that it is a fourth degree felony to commit the offense of offering or paying illegal kickbacks.

### NON-COLLUSION

In signing their Bid and Affidavit, the Bidder certifies that he/she has not, either directly or indirectly entered into action of restraint of free competition, in the connection with the submitted bid.

### RESPONSIBILITY OF BIDDER

At all times it shall be the responsibility of the Bidder to see their bid is delivered to the City Clerk by the Date and Time scheduled for opening. If the mail or delivery of said Bid is delayed beyond the scheduled opening date and time set, this bid will not be considered.

CLARIFICATION OF BID

Bidder requiring clarification or interpretation of Bid specifications shall make a written request to the Department involved in this bid request at least five (5) days prior to the scheduled bid opening date with a copy forwarded to the Finance Department. Any interpretation, corrections or changes of said Bid Specifications, Opening Date, or Time Change will be made by Addendum only. Interpretations, Corrections or changes of said bid made in any other manner will not be binding and the Bidder shall not rely upon such interpretation, corrections and changes.

MODIFICATION OF BID

Bids may be withdrawn upon receipt of written request prior to the scheduled bid opening for the purpose of making any corrections or changes. Such corrections must be properly identified and signed or initialed by the Bidder. Resubmission must be prior to the scheduled bid opening time in order to be considered. After bid opening, no price modifications of submitted bids or other provisions shall be permitted.

WITHDRAWAL OF BID

A low Bidder alleging a material mistake of fact, after bids have been opened may request their bid be withdrawn upon receipt of a written request to the Finance Department prior to the scheduled awarding date.

INSPECTION

Final inspection and acceptance will be made at the City's discretion. Products rejected for nonconformance with the specifications shall be removed by the Bidder; at his/her risk and expense promptly after notice of rejection.

FEDERAL TAX IDENTIFICATION NUMBER

Pursuant to IRS requirements, Bidder shall provide their Federal Tax ID Number if Bidder is incorporated. If Bidder is a sole proprietorship or partnership then they shall provide their Social Security Number.

FEDERAL TAX ID NUMBER: 84-0441361  
SOCIAL SECURITY NUMBER: \_\_\_\_\_

NEW MEXICO TAX IDENTIFICATION NUMBER

Payment may be withheld under (Section 7-10-5, N.M.S.A. 1978) if you are subject to New Mexico Gross Receipts Tax and have not registered for a New Mexico (CRS) Tax Identification Number. Contact the New Mexico Taxation & Revenue Department at (505) 827-0700 for registering instructions.

NEW MEXICO TAX IDENTIFICATION NO. (CRS): \_\_\_\_\_

## CAMPAIGN CONTRIBUTION DISCLOSURE FORM

The Bidder shall submit a completed Campaign Contribution Disclosure Form Pursuant to Chapter 81, Laws of 2006.

### COMMERCIAL WARRANTY

The Bidder agrees that the products or services furnished under a Purchase Order shall be covered by the most favorable commercial warranties that the Bidder gives to any customer for such products or services. And that the rights and remedies provided therein shall extend to the City and are in addition to and do not limit any rights afforded to the City by any other clause of its Purchase Order. Bidder agrees not to disclaim warranties of fitness for any particular purpose or merchantability.

Furthermore, Bidder agrees that its warranty for all products furnished under a Purchase Order pursuant to this Call for Bids shall be for a period of one year following the installation of said products by others. Also a receipt of a notice by the City's Engineer the products have been installed correctly and have been demonstrated to be capable of performing their intended function.

### SPECIAL NOTICE

To preclude possible errors and/or misinterpretations, bid prices must be affixed in ink or typewritten legibly. Enclose one (1) original and two (2) copies of Bid documents.

### DEFAULT

The City reserves the right to cancel all or any part of an order without cost to the City if the Bidder fails to meet the provisions of the City's Purchase Order or the product specifications and to hold the Bidder liable for any excess costs occasioned due to the Bidder's default. The Bidder shall not be liable for any excess costs if failure to perform on an order arises out of cause beyond the control and without fault or negligence of the Bidder. Such causes include, but are not restricted to, acts of God or public enemy; acts of State or Federal Government; fires, floods, epidemics, quarantine restrictions, strikes, embargoes, unusually severe weather, or defaults of subcontractors. Due to any of the above unless the City shall determine that the supplies or services to be furnished by the subcontractor are obtainable from other sources in the City in this paragraph shall not be exclusive and are in addition to any other rights now being provided by law.

### BID PROTESTS

If any Bidder is of the opinion that the specifications as written preclude him/her from submitting a bid. His/her opinion should be made known to the Department involved in this bid request at least twelve (12) days prior to the scheduled bid opening date with a copy forwarded to the Finance Department. Bid protests will not be considered from parties which do not also furnish satisfactory documentation with their protest that their proposed system fully meets the functional intent of the TECHNICAL SPECIFICATIONS which accompany a Call for Bids.



## NON-EXCLUSION

Specifications of the bid request are not meant to exclude any Bidder or Manufacturer. Where a brand name or equal is indicated, it is for the purpose of describing the standard of quality, performance and characteristics desired and is not intended to restrict competition. "No Substitute" specifications may be authorized, only if required to match existing equipment.

If any Bidder is of the opinion that the specifications as written preclude him/her from submitting a bid. His/her opinion should be made known to the Department involved in this bid request at least five (5) days prior to the scheduled bid opening date; with a copy forwarded to the Finance Department.

Brand names and numbers are for reference only and equivalents will be considered. If bidding "EQUIVALENT" Bidder must be prepared to furnish complete data upon request, preferably with the bid to avoid awarding delay.

## CONTRACT

When the City issues a Purchase Order in response to an awarded Bid a binding contract is created (unless a specified contract has been created).

## TERMINATION

This Price Agreement may be terminated by either party upon signing a written notice to the other party at least thirty (30) days in advance of the date of termination. Notice of termination of this Price Agreement shall not affect any outstanding orders.

## TAXES

Bidder must pay all applicable taxes.

## NOTE:

If bidder is from outside the City of Las Vegas, the successful bidder must pay Gross Receipts in the City of Las Vegas.

BIDDER INFORMATION

BIDDER: MOUNTAIN STATES PIPE & SUPPLY
AUTHORIZED AGENT: SCOTT VANTEYCLINGEN
ADDRESS: 111 W. LAS VEGAS ST
TELEPHONE NUMBER (719) 475-4043
FAX NUMBER (719) 834-5551
DELIVERY: STOCK - 35 DAYS
STATE PURCHASING RESIDENT CERTIFICATION NO.: N/A
NEW MEXICO CONTRACTORS LICENSE NO.: N/A
BID ITEM (S): NATURAL GAS INVENTORY SUPPLY

ITEM (S) UNDER THIS BID ARE TO BE F.O.B. LAS VEGAS, NEW MEXICO 87701. THE CITY OF LAS VEGAS RESERVES THE RIGHT REJECT ANY OR ALL BIDS AND TO WAIVE ANY TECHINCAL IRREGULARITY IN THE FORM OF THE BID.

AFFIDAVIT FOR FILING WITH COMPETITIVE BID

STATE OF COLORADO
COUNTY OF EL PASO

I SCOTT VANTEYCLINGEN, of lawful age, being of first duly sworn in oath, say that I am the agent authorized by the bidder to submit the attached bid. Affiant further states that the bidder has not been a party to any collusion among bidders in restraint of freedom of competition by agreement to bid at a fixed price or to refrain from bidding; or with any city official or employee as to the terms of said prospective contract, or any other terms of said prospective contract; or in any discussion between bidders with any city official concerning an exchange of money or any other thing of value for special consideration in the letting of a contract.

Signature of Scott VanTeylingen

Subscribed and sworn to before me, this 28th day of November, 2016.

Notary Public Signature of Susan H Ayler

My Commission Expires: 11/16/2020

(SEAL) SUSAN H AYLER NOTARY PUBLIC STATE OF COLORADO NOTARY ID 19964006282 MY COMMISSION EXPIRES 11/16/2020

CITY OF LAS VEGAS

BID ITEM(S): NATURAL GAS INVENTORY SUPPLY

ITEM	DESCRIPTION	UNIT PRICE
1.	Roots-Series B3 Line Mount Meter's 11-M175 (TC)-4" Flange 8 Bolt <u>ROMET RM11000-TC</u>	<u>\$ 2925<sup>00</sup></u>
2.	American AL-1400 Diaphragm Meter 2" NPT 100 PSIG MAOP	<u>\$ 3500<sup>00</sup></u>
3.	American AL-800 Diaphragm Meter 45LT 1-1/2" NPT	<u>\$ 1540<sup>00</sup></u>
4.	American AL-2300 Diaphragm Meter 4" flanged connection 100psig MAOP	<u>\$ 5230<sup>00</sup></u>
5.	American AL-5000 Diaphragm Meter 4" flanged connection 100 psig MAOP	<u>\$ 6765<sup>00</sup></u>
6.	American 425 Natural Gas Meter	<u>\$ 415<sup>00</sup></u> 4 PC MIN
7.	American AC 630 Natural Gas Meter	<u>\$ 820<sup>00</sup></u> 4 PC MIN
8.	American AL-1000 Diaphragm meter 45LT, 1-1/2" NPT	<u>\$ 1885<sup>00</sup></u> 2 PC MIN
9.	750/1600 Natural Gas Meter w/max working pressure 100lb - w/standard connections 45LT	<u>\$ 2375<sup>00</sup></u> 2 PC MIN
10.	1000 Natural Gas Meter working pressure 25lb	
11.	Model-441-57S Self-Operated Low and High Pressure Large Capacity Regulators 4" 8 Bolt Flange ASME	<u>NO BID</u>
12.	Model-046-2Field High Pressure Service Regulator 1"x1"	<u>NO BID</u>
13.	275 TC Meter w/1" connections, galvanized. One side insulated. Or equal	<u>NO BID</u>
14.	2" x 2" 243-8-2 regulator IRV, 6" to 14" spring, w/3/8" orifice. Or equal	<u>NO BID</u>
15.	2" x 2" 243-HP Regulator, IRV w/1/2" orifice. 3 PSI to 10 PSI or equal to	<u>NO BID</u>
16.	1" x1" 143-80-2 regulator. IRV 6" to 14" spring. 3/8" orifice. Or equal	<u>NO BID</u>
17.	3/4" x 3/4" Model 496 regulator. IRV 6" to 14" spring. 1/8" orifice. Or equal	<u>NO BID</u>
18.	1" x 1" 143-80-2 HP regulator IRV 2-6 PSI, 3/8" orifice. Or equal	<u>NO BID</u>
19.	1" x 1" Model 496 regulator IRV 6" to 14" spring. 1/8" orifice. Or equal	<u>NO BID</u>

- |     |  |   |
|-----|--|---|
| 20. | 2 x 2-243-RPC-B Regulator. 1/2" orifice - 10 PSIG-35 PSI.<br>Or equal                                    | <u>NO BID</u>                                       |
| 21. | 45LT x 1 1/4" galvanized gas meter connection Per Set  | <u>NO BID</u><br><u>\$ 27<sup>84</sup></u> 5 PC MIN |
| 22. | 45LT x 1 1/2" galvanized insulated gas meter connection.<br>Per Set Insulated                            | <u>\$ 29<sup>00</sup></u> 5 PC MIN                  |
| 23. | 20LT x 1" M.P.T. galvanized swivel & nut Per Set -<br>Insulated  | <u>\$ 13<sup>62</sup></u> 50 PC MIN                 |
| 24. | 3/4" Polyethylene Gas Pipe Performance Pipe PE 3408-<br>A.S.T.M-D-2513 or equal                          | <u>NO BID</u>                                       |
| 25. | 1" Polyethylene Gas Pipe Performance Pipe PE 3408-<br>A.S.T.M-D-2513 or equal                            | <u>NO BID</u>                                       |
| 26. | 1 1/4" Polyethylene Gas Pipe Performance Pipe PE 3408-<br>A.S.T.M-D-2513 or equal                        | <u>NO BID</u>                                       |
| 27. | 2" Polyethylene Gas Pipe Performance Pipe PE 3408 -<br>A.S.T.M-D-2513 or equal                           | <u>NO BID</u>                                       |
| 28. | 4" Polyethylene Gas Pipe Performance Pipe PE 3408-<br>A.S.T.M-D-2513 or equal                            | <u>NO BID</u>                                       |
| 29. | 4" IPS Transition fitting steel weld end x PE 3408 butt<br>connection- A.S.T.M-D-2513                    | <u>\$ 125<sup>00</sup></u>                          |
| 30. | 2" IPS Transition fitting steel weld end x PE 3408 Butt<br>connection- A.S.T.M-D-2513                    | <u>\$ 48<sup>00</sup></u>                           |
| 31. | 1" IPS Transition fitting steel weld end x PE 3408 Butt<br>connection- A.S.T.M-D-2513                    | <u>\$ 35<sup>00</sup></u>                           |
| 32. | PQ-11-Bypass Tee 2" IPS main x 2" IPS Abandonment<br>outlet Part#-5662-17-1017-00 Continental Industries | <u>NO BID</u>                                       |
| 33. | 4" PE 3408 butt fusion connection cap- A.S.T.M-D-2513  | <u>\$ 18<sup>18</sup></u> 10 PC MIN                 |
| 34. | 2" PE 3408 butt fusion connection cap- A.S.T.M-D-2513  | <u>\$ 3<sup>93</sup></u> 10 PC MIN                  |
| 35. | 1" PE 3408 butt fusion connection cap- A.S.T.M-D-2513  | <u>\$ 8<sup>25</sup></u> 10 PC MIN                  |
| 36. | 4"x 2 PE 3408 butt fusion connection - A.S.T.M-D-2513<br>Reducer   | <u>\$ 19<sup>17</sup></u> 10 PC MIN                 |
| 37. | 2" x 1" PE 3408 butt fusion connection - A.S.T.M-D-2513<br>Reducer                                       | <u>\$ 11<sup>88</sup></u> 10 PC MIN                 |

38.	1 1/4" x 1" PE 3408 butt fusion connection Reducer	<u>\$13<sup>38</sup></u> 10 PC MIN
39.	1" x 3/4" PE 3408 butt fusion connection Reducer	<u>\$9<sup>57</sup></u> 10 PC MIN
40.	1 1/4" x 2" PE 3408 butt fusion connection Reducer	<u>\$12<sup>12</sup></u> 10 PC MIN
41.	1 1/4" PE 3408 butt fusion connection cap	<u>\$5<sup>49</sup></u> 10 PC MIN
42.	2" PE 3408 butt fusion connection Tee – A.S.T.M-D-2513 Tee	<u>\$9<sup>65</sup></u> 10 PC MIN
43.	4" PE 3408 butt fusion connection Tee – A.S.T.M-D-2513 Tee	<u>\$32<sup>46</sup></u> 10 PC MIN
44.	1" PE 3408 butt fusion connection 90 degree elbow-A.S.T.M-D2513	<u>\$9<sup>85</sup></u> 10 PC MIN
45.	1 1/4" PE 3408 butt fusion connection 90 degree elbow– A.S.T.M-D-2513	<u>\$10<sup>35</sup></u> 10 PC MIN
46.	1" Butt fusion connection Tee– A.S.T.M-D-2513	<u>\$10<sup>95</sup></u> 10 PC MIN
47.	2" PE 3408 butt fusion connection 90 degree elbow– A.S.T.M-D-2513	<u>\$8<sup>16</sup></u> 10 PC MIN
48.	4" PE 3408 butt fusion connection 90 degree elbow– A.S.T.M-D-2513	<u>\$25<sup>20</sup></u> 4 PC MIN
49.	2" x 1" PE tapping tee assembly– A.S.T.M-D-2513	<u>NO BID</u>
50.	2" x 2" PE tapping tee assembly– A.S.T.M-D-2513	<u>NO BID</u>
51.	4" x 1" PE tapping tee assembly	<u>NO BID</u>
52.	4" x 2" PE tapping tee assembly	<u>NO BID</u>
	Note: Tapping tee assemblies to be adaptable to performance pipe PE 3408 fusion connections or equal	
53.	Anodeless service riser. 1" x1" By pass -SDR-11-P.E. 3408 R.W. Lyall or equal– A.S.T.M-D-2513	<u>NO BID</u>
54.	Anodeless service riser. 1" IPS x 1" NPT-SDR-11-P.E. 3408 R.W. Lyall or equal– A.S.T.M-D-2513	<u>\$55<sup>00</sup></u> 10 PC MIN
55.	Anodeless service riser. 2" NPT x 2" IPS SDR11-P.E. 3408 R.W. Lyall or equal– A.S.T.M-D-2513	<u>\$175<sup>00</sup></u> 5 PC MIN
56.	2" PE 3408 Valve– A.S.T.M-D-2513	<u>\$140<sup>00</sup></u> 2 PC MIN
57.	4" PE 3408 Valve– A.S.T.M-D-2513	<u>\$355<sup>00</sup></u> 2 PC MIN

58.	2" x 2"-175 Mueller Lubeseal in line pvc valve	<u>\$ 88<sup>00</sup></u>
59.	2" x 1" gas service saddle PVC w/compression outlet. Continental #5361-1014 or equal	<u>NO BID</u>
60.	1 1/4" pipe joint clamp MB Skinner #089862 or equal	<u>NO BID</u>
61.	1 1/2" pipe joint clamp MB Skinner #089861 or equal	<u>NO BID</u>
62.	2" pipe joint clamp MB Skinner #089860 or equal	<u>NO BID</u>
63.	4" line stopper fitting 250 P.S.I. Mueller #H17190 or equal	<u>\$ 170<sup>39</sup></u> 4 PC MIN
64.	2" line stopper fitting 250 P.S.I. Mueller #H17190 or equal	<u>\$ 72.76</u> 6 PC MIN <u>NO BID</u>
65.	2" plug valve, lubricated w/flange connection. CI for gas	<u>NO BID</u>
66.	2" plug valve, lubricated w/threaded ends. CI for gas	<u>NO BID</u>
67.	4" plug valve, lubricated w/flange ends. CI for gas	<u>NO BID</u>
68.	Meter barrel lock. Mueller #504979 or equal	<u>\$ 10.<sup>00</sup></u> 50 PC MIN
69.	3" line stoppers fittings 250. P.S.I. Mueller	<u>\$ 147<sup>96</sup></u> 5 PC MIN
70.	3/4" Mueller steel auto perf tee or equal	<u>\$ 25<sup>81</sup></u> 25 PC MIN
71.	1" Mueller steel autoperf tee or equal	<u>\$ 33<sup>84</sup></u> 25 PC MIN
72.	3/4" IPS x 1" IPS transition Punch Tee	<u>\$ 69<sup>36</sup></u> 10 PC MIN
73.	Thermoweld cartridge #15 CP Box of 20	<u>\$ 70<sup>00</sup></u> 1 BOX MIN
74.	2" PVC to PVC compression for gas	<u>NO BID</u>
75.	1" PVC T PVC compression coupling for gas	<u>NO BID</u>
76.	Lock wing iron body meter stop Inlet: 1" inside I.P. thread Outlet: 1" insulated union coupling w/inside I.P. thread. Finish: black or brass. 175 P.S.I.	<u>\$ 49<sup>62</sup></u> 10 PC MIN
77.	Lock wing iron body meter stop Inlet: 1" inside I.P. thread Outlet: 1" inside I.P. thread Finish: Black or brass 175 P.S.I.	<u>\$ 33<sup>94</sup></u> 15 PC MIN
78.	Tinker & Razor Half Cell reference electrodes Model-6-B-cucu 504 Half cell 1/4" x 6"	<u>NO BID</u>
79.	CuCu-504 crystals 1lb. 3ox bottle P#04-9011	<u>NO BID</u>
80.	Ceramic Tip Assembly- Pointed P#118-027	<u>NO BID</u>

81.	2 x 1 – PE 4710 HDPE Tapping Tee w/Rectangular Base & Model EFVEB-BB7YY00	<u>NO BID</u>
82.	4 x 1 –PE-4710-HDPE Tapping Tee w/Rectangular Base & model EFVEB-BB7YY00 Excess Flow Valve	<u>NO BID</u>
83.	Excess Flow Valve Model B – w/minimum Trip Point of 525SCFit @ 10 P.S.I. Stick Type	<u>NO BID</u>
84.	2" PVC to 2" IPS Transition Fitting	<u>NO BID</u>
85.	Valve Boxes Plastic for 2" to 3" FP Valve-31	<u>NO BID</u>
86.	Valve Supports for 2" Valve	<u>NO BID</u>
87.	Valve Supports for 4" Valve	<u>NO BID</u>
88.	Trenton wax tape 6"x9' (16 rolls per case)	<u>NO BID</u>
89.	Trenton wax tape primer brown (4 gal per case)	<u>NO BID</u>
90.	Barricade tape Gas Line Below yellow & black (8 rolls per case)	<u>\$18<sup>50</sup>/ROLL</u> 8 ROLL MIN
91.	#12 Solid BC .030 w/yellow tracer wire 500 ft (500 ft rolls/ 4 rolls per case)	<u>\$.20/LF</u> 2000' MIN
92.	Harveys 10 mil Pipe Wrap 2" x 100' (24 per case) 3M #50	<u>\$24<sup>82</sup>/RL</u> 24 RL MIN
93.	Magnesium–Anode – HC – Potential – 32lb	<u>NO BID</u>
94.	Magnesium – Anodes – 5lbs H.C	<u>NO BID</u>
95.	Magnesium-Anodes-9lb H.C.	<u>\$70<sup>00</sup></u> 5 PC MIN
96.	Magnesium – Anodes – 17lbs H.C	<u>\$130<sup>00</sup></u> 5 PC MIN
97.	Magnesium – Anodes – 50lbs H.C	<u>NO BID</u>
98.	Leak Detection Low temp Leak locator	<u>\$20.00/GALLON</u> 4 GAL MIN
99.	White/Yellow line locate paint, inverted marking paint	<u>\$5<sup>00</sup>/CAN</u> 24 CAN MIN

Note:

1. Bid prices to remain firm for a period of one (1) year after date of bid awardment.
2. All items to be F.O.B. City of Las Vegas, Utility Center, 905 12<sup>th</sup> Street Las Vegas, NM 87701.
3. Unit Price Includes Freight and Sales Tax on taxable item on unit bid.
4. The City of Las Vegas reserves the right to award bid on an individual item basis.
5. Item 13, R275 meter, maximum allowable operating pressure to be 5 PSI. To be equipped with 1" Connection

## CAMPAIGN CONTRIBUTION DISCLOSURE FORM

Pursuant to Chapter 81, Laws of 2006, any prospective contractor seeking to enter into a contract with any state agency or local public body must file this form with that state agency or local public body. The prospective contractor must disclose whether they, a family member or a representative of the prospective contractor has made a campaign contribution to an applicable public official of the state or a local public body during the two years prior to the date on which the contractor submits a proposal or, in the case of a sole source or small purchase contract, the two years prior to the date the contractor signs the contract, if the aggregate total of contributions given by the prospective contractor, a family member or a representative of the prospective contractor to the public official exceeds two hundred and fifty dollars (\$250) over the two year period.

**THIS FORM MUST BE FILED BY ANY PROSPECTIVE CONTRACTOR WHETHER OR NOT THEY, THEIR FAMILY MEMBER, OR THEIR REPRESENTATIVE HAS MADE ANY CONTRIBUTIONS SUBJECT TO DISCLOSURE.**

The following definitions apply:

"Applicable public official" means a person elected to an office or a person appointed to complete a term of an elected office, who has the authority to award or influence the award of the contract for which the prospective contractor is submitting a competitive sealed proposal or who has the authority to negotiate a sole source or small purchase contract that may be awarded without submission of a sealed competitive proposal.

"Campaign Contribution" means a gift, subscription, loan, advance or deposit of money or other thing of value, including the estimated value of an in-kind contribution, that is made to or received by an applicable public official or any person authorized to raise, collect or expend contributions on that official's behalf for the purpose of electing the official to either statewide or local office. "Campaign Contribution" includes the payment of a debt incurred in an election campaign, but does not include the value of services provided without compensation or unreimbursed travel or other personal expenses of individuals who volunteer a portion or all of their time on behalf of a candidate or political committee, nor does it include the administrative or solicitation expenses of a political committee that are paid by an organization that sponsors the committee.

"Contract" means any agreement for the procurement of items of tangible personal property, services, professional services, or construction.

"Family member" means spouse, father, mother, child, father-in-law, mother-in-law, daughter-in-law or son-in-law.

"Pendency of the procurement process" means the time period commencing with the public notice of the request for proposals and ending with the award of the contract or the cancellation of the request for proposals.

"Person" means any corporation, partnership, individual, joint venture, association or any other private legal entity.

"Prospective contractor" means a person who is subject to the competitive sealed



proposal process set forth in the Procurement Code or is not required to submit a competitive sealed proposal because that person qualifies for a sole source or a small purchase contract.

"Representative of a prospective contractor" means an officer or director of a corporation, a member or manager of a limited liability corporation, a partner of a partnership or a trustee of a trust of the prospective contractor.

**DISCLOSURE OF CONTRIBUTIONS:**

Contribution Made By: \_\_\_\_\_

Relation to Prospective Contractor: \_\_\_\_\_

Name of Applicable Public Official: \_\_\_\_\_

Date Contribution(s) Made: \_\_\_\_\_

Amount(s) of Contribution(s) \_\_\_\_\_

Nature of Contribution(s) \_\_\_\_\_

Purpose of Contribution(s) \_\_\_\_\_

(The above fields are unlimited in size) \_\_\_\_\_

\_\_\_\_\_  
Signature

\_\_\_\_\_  
Date

\_\_\_\_\_  
Title (position)

-OR-

**NO CONTRIBUTIONS IN THE AGGREGATE TOTAL OVER TWO HUNDRED FIFTY DOLLARS (\$250) WERE MADE to an applicable public official by me, a family member or representative.**

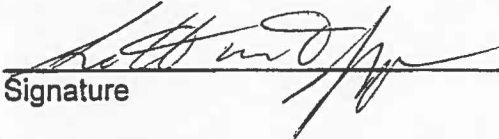
  
\_\_\_\_\_  
Signature

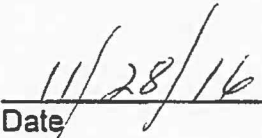
  
\_\_\_\_\_  
Date

  
\_\_\_\_\_  
Title (Position)

REQUEST FOR BIDS

The City of Las Vegas, New Mexico will open Sealed Bids at 2:00 p.m., Dec 1, 2016 at 3:00 pm the City Council Chambers, 1700 North Grand Avenue, Las Vegas, New Mexico, or other designated area at the City Offices; ON THE FOLLOWING:

NATURAL GAS INVENTORY SUPPLIES

The BIDDING FORMS AND TECHNICAL SPECIFICATIONS may be examined at the following location: 1700 NORTH GRAND, LAS VEGAS, NM

Copies of the BIDDING FORMS AND TECHNICAL SPECIFICATIONS may be obtained at the office of: 1700 NORTH GRAND, LAS VEGAS, NM

Mailed Bids should be addressed to the City Clerk, 1700 N. Grand Ave., Las Vegas, New Mexico 87701; with the envelope marked: NATURAL GAS INVENTORY SUPPLIES, Opening No. 2017-12; on the lower left-hand corner of the submitted envelope. It shall be the responsibility of the bidder to see that their bid is delivered to the City Clerk by the date and time set for the bid request. If the mail or delivery of bid request is delayed beyond the opening date and time, bid thus delayed will not be considered. A public opening will be held and any bidder or their authorized representative is invited to attend.

The City of Las Vegas reserves the right to reject any/or all bids submitted.

CITY OF LAS VEGAS,

Richard R. Trujillo  
RICHARD TRUJILLO, CITY MANAGER

H. Chico Gallegos  
H. CHICO GALLEGOS, CITY ATTORNEY

Cassandra Fresquez  
CASANDRA FRESQUEZ, CITY CLERK

Ann M. Gallegos  
ANN M. GALLEGOS, FINANCE DIRECTOR

Helen Vigil  
HELEN VIGIL, PURCHASING OFFICER

Opening No. 2017-12

Date Issued: 11/2/2016

Date Issued: Published:

Albuquerque Journal Nov 16, 2016  
Las Vegas Optic Nov 16, 2016  
City website: www.lasvegasnm.gov

R

DEC 01 2016

CITY OF LAS VEGAS  
PURCHASING DEPT.

3:00 pm

## STANDARD BID CLAUSES

### AWARDED BID

Awarding of Bid shall be made to the responsible Bidder whose Bid meets the required specifications. The City of Las Vegas (City) reserves the right to reject or accept any of all Bid specifications and to waive any insubstantial irregularity in the form of the Bid.

The City of Las Vegas may make multiple awards of the bid, to those bidding in law enforcement related services. The City Reserves the right to award the bid to the most advantageous Bidder to the City.

### TIMETABLE

Bids pursuant to this request must be received at the City Clerk's Office at 1700 North Grand Avenue, Las Vegas, New Mexico, on or before 3:00 pm, Dec 1, 2016 at which time all bids received will be opened. An opening will occur at the City's Council Chambers or other designated area at the City Offices. Awarding of Bid is projected for \_\_\_\_\_, 20\_\_\_\_. The successful Bidder will be notified by mail.

### ENVELOPES

Sealed Bid envelopes shall be clearly marked on the lower left-hand corner, identified by the Bid Name and Opening Number. Failure to comply with this requirement may result in the rejection of your submitted Bid. Enclose one (1) original and two (2) copies of Bid.

### BRIBERY AND KICKBACK

The Procurement Code of New Mexico; (Section 13-1-28 through 13-1-99 N.M.S.A. 1978), impose a third degree felony penalty for bribery of a public official or public employee. In addition the New Mexico Criminal Statutes (Section 30-4-1, N.M.S.A. 1978): state that it is a third degree felony to commit the offense of demanding or receiving a bribe by a public official of public employee. And (Section 30-24-2, N.M.S.A. 1978): it is a fourth degree felony to commit the offense of soliciting or receiving illegal kickbacks. Also (Section 30-41-1 through 30-41-3, N.M.S.A. 1978): states that it is a fourth degree felony to commit the offense of offering or paying illegal kickbacks.

### NON-COLLUSION

In signing their Bid and Affidavit, the Bidder certifies that he/she has not, either directly or indirectly entered into action of restraint of free competition, in the connection with the submitted bid.

### RESPONSIBILITY OF BIDDER

At all times it shall be the responsibility of the Bidder to see their bid is delivered to the City Clerk by the Date and Time scheduled for opening. If the mail or delivery of said Bid is delayed beyond the scheduled opening date and time set, this bid will not be considered.

**CLARIFICATION OF BID**

Bidder requiring clarification or interpretation of Bid specifications shall make a written request to the Department involved in this bid request at least five (5) days prior to the scheduled bid opening date with a copy forwarded to the Finance Department. Any interpretation, corrections or changes of said Bid Specifications, Opening Date, or Time Change will be made by Addendum only. Interpretations, Corrections or changes of said bid made in any other manner will not be binding and the Bidder shall not rely upon such interpretation, corrections and changes.

**MODIFICATION OF BID**

Bids may be withdrawn upon receipt of written request prior to the scheduled bid opening for the purpose of making any corrections or changes. Such corrections must be properly identified and signed or initialed by the Bidder. Resubmission must be prior to the scheduled bid opening time in order to be considered. After bid opening, no price modifications of submitted bids or other provisions shall be permitted.

**WITHDRAWAL OF BID**

A low Bidder alleging a material mistake of fact, after bids have been opened may request their bid be withdrawn upon receipt of a written request to the Finance Department prior to the scheduled awarding date.

**INSPECTION**

Final inspection and acceptance will be made at the City's discretion. Products rejected for nonconformance with the specifications shall be removed by the Bidder; at his/her risk and expense promptly after notice of rejection.

**FEDERAL TAX IDENTIFICATION NUMBER**

Pursuant to IRS requirements, Bidder shall provide their Federal Tax ID Number if Bidder is incorporated. If Bidder is a sole proprietorship or partnership then they shall provide their Social Security Number.

FEDERAL TAX ID NUMBER: 76-0320316  
SOCIAL SECURITY NUMBER: \_\_\_\_\_

**NEW MEXICO TAX IDENTIFICATION NUMBER**

Payment may be withheld under (Section 7-10-5, N.M.S.A. 1978) if you are subject to New Mexico Gross Receipts Tax and have not registered for a New Mexico (CRS) Tax Identification Number. Contact the New Mexico Taxation & Revenue Department at (505) 827-0700 for registering instructions.

NEW MEXICO TAX IDENTIFICATION NO. (CRS): 02-463323-002

## CAMPAIGN CONTRIBUTION DISCLOSURE FORM

The Bidder shall submit a completed Campaign Contribution Disclosure Form Pursuant to Chapter 81, Laws of 2006.

### COMMERCIAL WARRANTY

The Bidder agrees that the products or services furnished under a Purchase Order shall be covered by the most favorable commercial warranties that the Bidder gives to any customer for such products or services. And that the rights and remedies provided therein shall extend to the City and are in addition to and do not limit any rights afforded to the City by any other clause of its Purchase Order. Bidder agrees not to disclaim warranties of fitness for any particular purpose or merchantability.

Furthermore, Bidder agrees that its warranty for all products furnished under a Purchase Order pursuant to this Call for Bids shall be for a period of one year following the installation of said products by others. Also a receipt of a notice by the City's Engineer the products have been installed correctly and have been demonstrated to be capable of performing their intended function.

### SPECIAL NOTICE

To preclude possible errors and/or misinterpretations, bid prices must be affixed in ink or typewritten legibly. Enclose one (1) original and two (2) copies of Bid documents.

### DEFAULT

The City reserves the right to cancel all or any part of an order without cost to the City if the Bidder fails to meet the provisions of the City's Purchase Order or the product specifications and to hold the Bidder liable for any excess costs occasioned due to the Bidder's default. The Bidder shall not be liable for any excess costs if failure to perform on an order arises out of cause beyond the control and without fault or negligence of the Bidder. Such causes include, but are not restricted to, acts of God or public enemy; acts of State or Federal Government; fires, floods, epidemics, quarantine restrictions, strikes, embargoes, unusually severe weather, or defaults of subcontractors. Due to any of the above unless the City shall determine that the supplies or services to be furnished by the subcontractor are obtainable from other sources in the City in this paragraph shall not be exclusive and are in addition to any other rights now being provided by law.

### BID PROTESTS

If any Bidder is of the opinion that the specifications as written preclude him/her from submitting a bid. His/her opinion should be made known to the Department involved in this bid request at least twelve (12) days prior to the scheduled bid opening date with a copy forwarded to the Finance Department. Bid protests will not be considered from parties which do not also furnish satisfactory documentation with their protest that their proposed system fully meets the functional intent of the TECHNICAL SPECIFICATIONS which accompany a Call for Bids.

## NON-EXCLUSION

Specifications of the bid request are not meant to exclude any Bidder or Manufacturer. Where a brand name or equal is indicated, it is for the purpose of describing the standard of quality, performance and characteristics desired and is not intended to restrict competition. "No Substitute" specifications may be authorized, only if required to match existing equipment.

If any Bidder is of the opinion that the specifications as written preclude him/her from submitting a bid. His/her opinion should be made known to the Department involved in this bid request at least five (5) days prior to the scheduled bid opening date; with a copy forwarded to the Finance Department.

Brand names and numbers are for reference only and equivalents will be considered. If bidding "EQUIVALENT" Bidder must be prepared to furnish complete data upon request, preferably with the bid to avoid awarding delay.

## CONTRACT

When the City issues a Purchase Order in response to an awarded Bid a binding contract is created (unless a specified contract has been created).

## TERMINATION

This Price Agreement may be terminated by either party upon signing a written notice to the other party at least thirty (30) days in advance of the date of termination. Notice of termination of this Price Agreement shall not affect any outstanding orders.

## TAXES

Bidder must pay all applicable taxes.

## NOTE:

If bidder is from outside the City of Las Vegas, the successful bidder must pay Gross Receipts in the City of Las Vegas.

**BIDDER INFORMATION**

BIDDER: Secor

AUTHORIZED AGENT: Robert Keys

ADDRESS: 705 Rankin Road NE Albuquerque NM 87107

TELEPHONE NUMBER (505) 341-0777

FAX NUMBER (505) 341-0771

DELIVERY: Best Way - City of Las Vegas NM

STATE PURCHASING RESIDENT CERTIFICATION NO.: N/A

NEW MEXICO CONTRACTORS LICENSE NO.: N/A

BID ITEM (S): NATURAL GAS INVENTORY SUPPLY

ITEM (S) UNDER THIS BID ARE TO BE F.O.B. LAS VEGAS, NEW MEXICO 87701. THE CITY OF LAS VEGAS RESERVES THE RIGHT REJECT ANY OR ALL BIDS AND TO WAIVE ANY TECHNICAL IRREGULARITY IN THE FORM OF THE BID.

**AFFIDAVIT FOR FILING WITH COMPETITIVE BID**

STATE OF New Mexico

COUNTY OF Bernalillo

I Robert Keys, of lawful age, being of first duly sworn in oath, say that I am the agent authorized by the bidder to submit the attached bid. Affiant further states that the bidder has not been a party to any collusion among bidders in restraint of freedom of competition by agreement to bid at a fixed price or to refrain from bidding; or with any city official or employee as to the terms of said prospective contract, or any other terms of said prospective contract; or in any discussion between bidders with any city official concerning an exchange of money or any other thing of value for special consideration in the letting of a contract.

[Signature]  
Signature

Subscribed and sworn to before me, this 28<sup>th</sup> day of November, 2016.

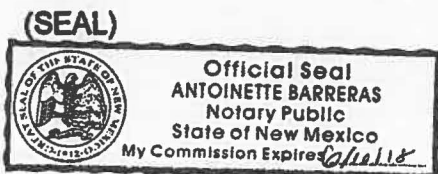

[Signature]  
Notary Public Signature  
My Commission Expires: 6/10/18

**CITY OF LAS VGAS**

**BID ITEM (S): NATURAL GAS INVENTORY SUPPLY**

---

<b>ITEM</b>	<b>DESCRIPTION</b>	<b>UNIT PRICE</b>
1.	Roots-Series B3 Line Mount Meter's 11-M175 (TC)-4" Flange 8 Bolt	1. <u>NO Bid</u>
2.	American AL-1400 Diaphragm Meter 2" NPT 100 PSIG MAOP	2. <u>NO Bid</u>
3.	American AL-800 Diaphragm Meter 45LT 1-1/2" NPT	3. <u>NO Bid</u>
4.	American AL-2300 Diaphragm Meter 4" flanged connection 100psig MAOP	4. <u>NO Bid</u>
5.	American AL-5000 Diaphragm Meter 4" flanged connectlon 100 psig MAOP	5. <u>NO Bid</u>
6.	American 425 Natural Gas Meter	6. <u>NO Bid</u>
7.	American AC 630 Natural Gas Meter	7. <u>NO Bid</u>
8.	American AL-1000 Diaphragm meter 45LT, 1-1/2" NPT	8. <u>NO Bid</u>
9.	750/1600 Natural Gas Meter w/max working pressure 100lb - w/standard connections 45LT	9. <u>NO Bid</u>
10.	1000 Natural Gas Meter working pressure 25lb	10. <u>NO Bid</u>
11.	Model-441-57S Self-Operated Low and High Pressure Large Capacity Regulators 4" 8 Bolt Flange ASME	11. <u>NO Bid</u>
12.	Model-046-2Field High Pressure Service Regulator 1"x1"	12. <u>NO Bid</u>
13.	275 TC Meter w/1" connections, galvanized. One side insulated. Or equal	13. <u>NO Bid</u>
14.	2" x 2" 243-8-2 regulator IRV, 6" to 14" spring, w/3/8" orifice. Or equal	14. <u>NO Bid</u>
15.	2" x 2" 243-HP Regulator, IRV w/1/2" orifice. 3 PSI to 10 PSI or equal to	15. <u>NO Bid</u>
16.	1" x1" 143-80-2 regulator. IRV 6" to 14" spring. 3/8" orifice. Or equal	16. <u>NO Bid</u>
17.	3/8" x 3/8" Model 496 regulator. IRV 6" to 14" spring. 1/8" orifice. Or equal	17. <u>NO Bid</u>
18.	1" x 1" 143-80-2 HP regulator IRV 2-6 PSI, 3/8" orifice. Or equal	18. <u>NO Bid</u>
19.	1" x 1" Model 496 regulator IRV 6" to 14" spring. 1/8" orifice. Or equal	19. <u>NO Bid</u>



20.	2 x 2-243-RPC-B Regulator. ½" orifice – 10 PSIG-35 PSI. Or equal	20.	<u>No Bid</u>
21.	45LT x 1 ¼" galvanized gas meter connection Per Set	21.	<u>No Bid</u>
22.	45LT x 1 ½" galvanized insulated gas meter connection. Per Set Insulated	22.	<u>No Bid</u>
23.	20LT x 1" M.P.T. galvanized swivel & nut Per Set - Insulated	23.	<u>No Bid</u>
24.	¾" Polyethylene Gas Pipe Performance Pipe PE 3408– A.S.T.M-D-2513 or equal	24.	<u>1.56 Ft.</u>
25.	1" Polyethylene Gas Pipe Performance Pipe PE 3408– A.S.T.M-D-2513 or equal	25.	<u>1.71 Ft.</u>
26.	1 ¼" Polyethylene Gas Pipe Performance Pipe PE 3408– A.S.T.M-D-2513 or equal	26.	<u>1.99 Ft.</u>
27.	2" Polyethylene Gas Pipe Performance Pipe PE 3408 – A.S.T.M-D-2513 or equal	27.	<u>2.59 Ft.</u>
28.	4" Polyethylene Gas Pipe Performance Pipe PE 3408– A.S.T.M-D-2513 or equal	28.	<u>9.88 Ft.</u>
29.	4" IPS Transition fitting steel weld end x PE 3408 butt connection– A.S.T.M-D-2513	29.	<u>91.76 ea.</u>
30.	2" IPS Transition fitting steel weld end x PE 3408 Butt connection– A.S.T.M-D-2513	30.	<u>50.67 ea.</u>
31.	1" IPS Transition fitting steel weld end x PE 3408 Butt connection– A.S.T.M-D-2513	31.	<u>37.47 ea.</u>
32.	PQ-11-Bypass Tee 2" IPS main x 2" IPS Abandonment outlet Part#-5662-17-1017-00 Continental Industries	32.	<u>274.33 ea.</u>
33.	4" PE 3408 butt fusion connection cap– A.S.T.M-D-2513	33.	<u>22.87 ea.</u>
34.	2" PE 3408 butt fusion connection cap– A.S.T.M-D-2513	34.	<u>13.13 ea.</u>
35.	1" PE 3408 butt fusion connection cap– A.S.T.M-D-2513	35.	<u>14.07 ea.</u>
36.	4"x 2 PE 3408 butt fusion connection – A.S.T.M-D-2513 Reducer	36.	<u>21.56 ea.</u>
37.	2" x 1" PE 3408 butt fusion connection – A.S.T.M-D-2513 Reducer	37.	<u>15.87 ea.</u>

38.	1 1/4" x 1" PE 3408 butt fusion connection Reducer	38.	<u>18.79 ea.</u>
39.	1" x 3/4" PE 3408 butt fusion connection Reducer	39.	<u>17.43 ea.</u>
40.	1 1/4" x 2" PE 3408 butt fusion connection Reducer	40.	<u>15.97 ea.</u>
41.	1 1/4" PE 3408 butt fusion connection cap	41.	<u>13.71 ea.</u>
42.	2" PE 3408 butt fusion connection Tee - A.S.T.M-D-2513 Tee	42.	<u>17.70 ea.</u>
43.	4" PE 3408 butt fusion connection Tee - A.S.T.M-D-2513 Tee	43.	<u>37.31 ea.</u>
44.	1" PE 3408 butt fusion connection 90 degree elbow-A.S.T.M-D2513	44.	<u>14.51 ea.</u>
45.	1 1/4" PE 3408 butt fusion connection 90 degree elbow- A.S.T.M-D-2513	45.	<u>15.36 ea.</u>
46.	1" Butt fusion connection Tee- A.S.T.M-D-2513	46.	<u>15.79 ea.</u>
47.	2" PE 3408 butt fusion connection 90 degree elbow- A.S.T.M-D-2513	47.	<u>15.99 ea.</u>
48.	4" PE 3408 butt fusion connection 90 degree elbow- A.S.T.M-D-2513	48.	<u>32.76 ea.</u>
49.	2" x 1" PE tapping tee assembly- A.S.T.M-D-2513	49.	<u>31.43 ea.</u>
50.	2" x 2" PE tapping tee assembly- A.S.T.M-D-2513	50.	<u>124.29 ea.</u>
51.	4" x 1" PE tapping tee assembly	51.	<u>31.43 ea.</u>
52.	4" x 2" PE tapping tee assembly	52.	<u>124.29 ea.</u>
Note: Tapping tee assemblies to be adaptable to performance pipe PE 3408 fusion connections or equal			
53.	Anodeless service riser. 1" x 1" By pass -SDR-11-P.E. 3408 R.W. Lyall or equal- A.S.T.M-D-2513	53.	<u>NO Bid</u>
54.	Anodeless service riser. 1" IPS x 1" NPT-SDR-11-P.E. 3408 R.W. Lyall or equal- A.S.T.M-D-2513	54.	<u>58.87 ea.</u>
55.	Anodeless service riser. 2" NPT x 2" IPS SDR11-P.E. 3408 R.W. Lyall or equal- A.S.T.M-D-2513	55.	<u>141.24 ea.</u>
56.	2" PE 3408 Valve- A.S.T.M-D-2513	56.	<u>118.11 ea.</u>
57.	4" PE 3408 Valve- A.S.T.M-D-2513	57.	<u>350.43 ea.</u>

58.	2" x 2"-175 Mueller Lubeseal in-line pvc valve H-11175	58.	<u>176.69 ea.</u>
59.	2" x 1" gas service saddle PVC w/compression outlet. Continental # <del>5361-1014</del> or equal # 5864-17-1014-00	59.	<u>92.89 ea.</u>
60.	1 1/4" pipe joint clamp MB Skinner #089862 or equal	60.	<u>239.29 ea.</u>
61.	1 1/2" pipe joint clamp MB Skinner #089861 or equal	61.	<u>253.57 ea.</u>
62.	2" pipe joint clamp MB Skinner #089860 or equal	62.	<u>260.71 ea.</u>
63.	4" line stopper fitting 250 P.S.I. Mueller #H17190 or equal	63.	<u>211.69 ea.</u>
64.	2" line stopper fitting 250 P.S.I. Mueller #H17190 or equal	64.	<u>101.86 ea.</u>
65.	2" plug valve, lubricated w/flange connection. CI for gas	65.	<u>235.71 ea.</u>
66.	2" plug valve, lubricated w/threaded ends. CI for gas	66.	<u>180.44 ea.</u>
67.	4" plug valve, lubricated w/flange ends. CI for gas	67.	<u>499.00 ea.</u>
68.	Meter barrel lock. Mueller #504979 or equal	68.	<u>20.71 ea.</u>
69.	3" line stoppers fittings 250. P.S.I. Mueller	69.	<u>178.46 ea.</u>
70.	3/4" Mueller steel auto perf tee or equal H-18102	70.	<u>39.04 ea.</u>
71.	1" Mueller steel autoperf tee or equal H-18102	71.	<u>48.07 ea.</u>
72.	3/4" IPS x 1" IPS transition Punch Tee H-18104-04	72.	<u>88.03 ea.</u>
73.	Thermoweld cartridge #15 CP Box of 20	73.	<u>51.71 ea.</u>
74.	2" PVC to PVC compression for gas	74.	<u>No Bid</u>
75.	1" PVC T PVC compression coupling for gas	75.	<u>No Bid</u>
76.	Lock wing iron body meter stop Inlet: 1" inside I.P. thread Outlet: 1" insulated union coupling w/inside I.P. thread. Finish: black or brass. 175 P.S.I.	76.	<u>103.19 ea.</u>
77.	Lock wing iron body meter stop Inlet: 1" inside I.P. thread Outlet: 1" inside I.P. thread Finish: Black or brass 175 P.S.I.	77.	<u>71.67 ea.</u>
78.	Tinker & Razor Half Cell reference electrodes Model-6-B-cucu 504 Half cell 1/4" x 6"	78.	<u>103.57 ea.</u>
79.	CuCu-504 crystals 1lb. 3oz bottle P#04-9011	79.	<u>45.71 ea.</u>
80.	Ceramic Tip Assembly- Pointed P#118-027	80.	<u>36.43 ea.</u>

81.	2 x 1 – PE 4710 HDPE Tapping Tee w/Rectangular Base & Model EFVEB-BB7YY00	81.	<u>73.81</u>	ea.
82.	4 x 1 –PE-4710-HDPE Tapping Tee w/Rectangular Base & model EFVEB-BB7YY00 Excess Flow Valve	82.	<u>80.69</u>	ea.
83.	Excess Flow Valve Model B – w/minimum Trip Point of 525SCFit @ 10 P.S.I. Stick Type	83.	<u>32.10</u>	ea.
84.	2" PVC to 2" IPS Transition Fitting	84.	<u>70.36</u>	ea.
85.	Valve Boxes Plastic for 2" to 3" FP Valve-31	85.	<u>138.40</u>	ea.
86.	Valve Supports for 2" Valve	86.	<u>23.94</u>	ea.
87.	Valve Supports for 4" Valve	87.	<u>35.53</u>	ea.
88.	Trenton wax tape 6"x9' (16 rolls per case)	88.	<u>52.50</u>	ea.
89.	Trenton wax tape primer brown (4 gal per case)	89.	<u>153.07</u>	ea.
90.	Barricade tape Gas Line Below yellow & black (8 rolls per case)	90.	<u>32.86</u>	ea.
91.	#12 Solid BC .030 w/yellow tracer wire 500 ft (500 ft rolls/4 rolls per case)	91.	<u>0.24</u>	ft.
92.	Harveys 10 mil Pipe Wrap 2" x 100' (24 per case)	92.	<u>38.57</u>	ea.
93.	Magnesium–Anode – HC – Potential – 32lb	93.	<u>282.71</u>	ea.
94.	Magnesium – Anodes – 5lbs H.C	94.	<u>90.43</u>	ea.
95.	Magnesium-Anodes-9lb H.C.	95.	<u>135.79</u>	ea.
96.	Magnesium – Anodes – 17lbs H.C	96.	<u>201.86</u>	ea.
97.	Magnesium – Anodes – 50lbs H.C 48 lbs	97.	<u>474.14</u>	ea.
98.	Leak Detection Low temp Leak locator	98.	<u>58.14</u>	ea.
99.	White/Yellow line locate paint, inverted marking paint	99.	<u>83.57</u>	ea.

**Note:**

1. Bid prices to remain firm for a period of one (1) year after date of bid awardment.
2. All items to be F.O.B. City of Las Vegas, Utility Center, 905 12<sup>th</sup> Street Las Vegas, NM 87701.
3. Unit Price Includes Freight and Sales Tax on taxable item on unit bid.
4. The City of Las Vegas reserves the right to award bid on an individual item basis.
5. Item 13, R275 meter, maximum allowable operating pressure to be 5 PSI. To be equipped with 1" Connection

## CAMPAIGN CONTRIBUTION DISCLOSURE FORM

Pursuant to Chapter 81, Laws of 2006, any prospective contractor seeking to enter into a contract with any state agency or local public body must file this form with that state agency or local public body. The prospective contractor must disclose whether they, a family member or a representative of the prospective contractor has made a campaign contribution to an applicable public official of the state or a local public body during the two years prior to the date on which the contractor submits a proposal or, in the case of a sole source or small purchase contract, the two years prior to the date the contractor signs the contract, if the aggregate total of contributions given by the prospective contractor, a family member or a representative of the prospective contractor to the public official exceeds two hundred and fifty dollars (\$250) over the two year period.

**THIS FORM MUST BE FILED BY ANY PROSPECTIVE CONTRACTOR WHETHER OR NOT THEY, THEIR FAMILY MEMBER, OR THEIR REPRESENTATIVE HAS MADE ANY CONTRIBUTIONS SUBJECT TO DISCLOSURE.**

The following definitions apply:

"Applicable public official" means a person elected to an office or a person appointed to complete a term of an elected office, who has the authority to award or influence the award of the contract for which the prospective contractor is submitting a competitive sealed proposal or who has the authority to negotiate a sole source or small purchase contract that may be awarded without submission of a sealed competitive proposal.

"Campaign Contribution" means a gift, subscription, loan, advance or deposit of money or other thing of value, including the estimated value of an in-kind contribution, that is made to or received by an applicable public official or any person authorized to raise, collect or expend contributions on that official's behalf for the purpose of electing the official to either statewide or local office. "Campaign Contribution" includes the payment of a debt incurred in an election campaign, but does not include the value of services provided without compensation or unreimbursed travel or other personal expenses of individuals who volunteer a portion or all of their time on behalf of a candidate or political committee, nor does it include the administrative or solicitation expenses of a political committee that are paid by an organization that sponsors the committee.

"Contract" means any agreement for the procurement of items of tangible personal property, services, professional services, or construction.

"Family member" means spouse, father, mother, child, father-in-law, mother-in-law, daughter-in-law or son-in-law.

"Pendency of the procurement process" means the time period commencing with the public notice of the request for proposals and ending with the award of the contract or the cancellation of the request for proposals.

"Person" means any corporation, partnership, individual, joint venture, association or any other private legal entity.

"Prospective contractor" means a person who is subject to the competitive sealed

proposal process set forth in the Procurement Code or is not required to submit a competitive sealed proposal because that person qualifies for a sole source or a small purchase contract.

**"Representative of a prospective contractor"** means an officer or director of a corporation, a member or manager of a limited liability corporation, a partner of a partnership or a trustee of a trust of the prospective contractor.

**DISCLOSURE OF CONTRIBUTIONS:**

Contribution Made By: \_\_\_\_\_

Relation to Prospective Contractor: \_\_\_\_\_

Name of Applicable Public Official: \_\_\_\_\_

Date Contribution(s) Made: \_\_\_\_\_

Amount(s) of Contribution(s) \_\_\_\_\_

Nature of Contribution(s) \_\_\_\_\_

Purpose of Contribution(s) \_\_\_\_\_

(The above fields are unlimited in size) \_\_\_\_\_

\_\_\_\_\_  
Signature

\_\_\_\_\_  
Date

\_\_\_\_\_  
Title (position)

-OR-

**NO CONTRIBUTIONS IN THE AGGREGATE TOTAL OVER TWO HUNDRED FIFTY DOLLARS (\$250) WERE MADE to an applicable public official by me, a family member or representative.**

  
\_\_\_\_\_  
Signature

11/20/14  
\_\_\_\_\_  
Date

Inside Sales  
\_\_\_\_\_  
Title (Position)

# SECOR

## Project Quotation

Salesman: Robert Keys  
 Office: Albuquerque, NM  
 Phone: 505-341-0777  
 Facsimile: 505-341-0771  
 Date: November 22, 2016  
 Quote # 11222016RK1

Complete Piping Systems Serving:  
 Municipal, Industrial, Environmental,  
 Gas, and Mining Industries.

Project Name:  
 Location: Las Vegas, NM  
 Bid Date: December 1, 2016  
 Engineer:  
 Contractor: City of Las Vegas  
 Municipality:

Line Item	Quantity	Size	Manufacturer	Description	Unit Price	Total Price
24	500	3/4" IPS		PE4710 SDR-11 Blk x Yellow Stripe x 500'	\$1.56 ft.	\$778.57
25	500	1" IPS		PE4710 SDR-11 Blk x Yellow Stripe x 500'	\$1.71 ft.	\$857.14
26	500	1-1/4" IPS		PE4710 SDR-11 Blk x Yellow Stripe x 500'	\$1.99 ft.	\$992.86
27	500	2" IPS		PE4710 SDR-11 Blk x Yellow Stripe x 500'	\$2.59 ft.	\$1,292.86
28	40	4" IPS		PE4710 SDR-11 Blk x Yellow Stripe x 40'	\$9.88 ft.	\$395.29
29	1	4" IPS		PE4710 SDR-11 x Steel Weld-End Trans	\$91.76 ea.	\$91.76
30	1	2" IPS		PE4710 SDR-11 x Steel Weld-End Trans	\$50.67 ea.	\$50.67
31	1	1" IPS		PE4710 SDR-11 x Steel Weld-End Trans	\$37.47 ea.	\$37.47
32	1	2" IPS		PQ-11 Bypass Tee 2" IPS Main x 2" IPS	\$274.33 ea.	\$274.33
				Abandonment Outlet #5662-17-1017-00		
33	1	4" IPS		PE4710 SDR-11 B.F. Cap	\$22.87 ea.	\$22.87
34	1	2" IPS		PE4710 SDR-11 B.F. Cap	\$13.13 ea.	\$13.13
35	1	1" IPS		PE4710 SDR-11 B.F. Cap	\$14.07 ea.	\$14.07
36	1	4" x 2"		PE4710 SDR-11 B.F. Reducer	\$21.56 ea.	\$21.56
37	1	2" x 1"		PE4710 SDR-11 B.F. Reducer	\$15.87 ea.	\$15.87
38	1	1-1/4" - 1"		PE4710 SDR-11 B.F. Reducer	\$18.79 ea.	\$18.79
39	1	1" x 3/4"		PE4710 SDR-11 B.F. Reducer	\$17.43 ea.	\$17.43
40	1	2" x 1-1/4"		PE4710 SDR-11 B.F. Reducer	\$15.97 ea.	\$15.97
41	1	1-1/4" IPS		PE4710 SDR-11 B.F. Cap	\$13.71 ea.	\$13.71
42	1	2" IPS		PE4710 SDR-11 B.F. Tee	\$17.70 ea.	\$17.70
43	1	4" IPS		PE4710 SDR-11 B.F. Tee	\$37.31 ea.	\$37.31
44	1	1" IPS		PE4710 SDR-11 B.F. 90 Deg Elbow	\$14.51 ea.	\$14.51
45	1	1-1/4" IPS		PE4710 SDR-11 B.F. 90 Deg Elbow	\$15.36 ea.	\$15.36
46	1	1" IPS		PE4710 SDR-11 B.F. Tee	\$15.79 ea.	\$15.79
47	1	2" IPS		PE4710 SDR-11 B.F. 90 Deg Elbow	\$15.99 ea.	\$15.99
48	1	4" IPS		PE4710 SDR-11 B.F. 90 Deg Elbow	\$32.76 ea.	\$32.76
49	1	2" x 1"		PE4710 Tapping Tee Assembly # 1117813	\$31.43 ea.	\$31.43
50	1	2" x 2"		PE4710 Tapping Tee Assembly # 1096157	\$124.29 ea.	\$124.29
51	1	4" x 1"		PE4710 Tapping Tee Assembly # 1096144	\$31.43 ea.	\$31.43
52	1	4" x 2"		PE4710 Tapping Tee Assembly # 1096155	\$124.29 ea.	\$124.29
53	1	1" IPS		PE4710 Anodeless Service Riser w/ Bypass	No Bid ea.	No Bid
54	1	1" IPS		PE4710 Anodeless Service Riser	\$58.87 ea.	\$58.87

55	1	2" IPS		PE4710 Anodeless Service Riser	\$141.24 ea.	\$141.24	
56	1	2" IPS	Poly Valve	PE4710 Full Port B.F. Poly Valves	\$118.11 ea.	\$118.11	
57	1	4" IPS	Poly Valve	PE4710 Full Port B.F. Poly Valves	\$350.43 ea.	\$350.43	
58	1	2"	Mueller	Black Meter Stop 175 PSI H-11175	\$176.69 ea.	\$176.69	
59	1	2" x 1"		Gas Service Saddle PVC w/ Compression outlet # 5864-17-1014-00	\$92.89 ea.	\$92.89	
60	1	1-1/4"	Skinner	Pipe Joint Clamp MB Skinner #089862	\$239.29 ea.	\$239.29	
61	1	1-1/2"	Skinner	Pipe Joint Clamp MB Skinner #089861	\$253.57 ea.	\$253.57	
62	1	2"	Skinner	Pipe Joint Clamp MB Skinner #089860	\$260.71 ea.	\$260.71	
63	1	4"	Mueller	Line Stopper Fitting 250 PSI # H17190	\$211.69 ea.	\$211.69	
64	1	2"	Mueller	Line Stopper Fitting 250 PSI # H17190	\$101.86 ea.	\$101.86	
65	1	2"		Plug Valve Lubricated w/ Flange Connections	\$235.71 ea.	\$235.71	
66	1	2"		Plug Valve Lubricated w/ Threaded Connections	\$180.44 ea.	\$180.44	
67	1	4"		Plug Valve Lubricated w/ Flanged Connections	\$499.00 ea.	\$499.00	
68	1		Mueller	Meter Barrel Lock # 504978	\$20.71 ea.	\$20.71	
69	1	3"	Mueller	Line Stopper Fitting 250 PSI # H17190	\$178.46 ea.	\$178.46	
70	1	3/4"	Mueller	Steel Auto Perf Tee H-18102	\$39.04 ea.	\$39.04	
71	1	3/4" x 1"	Mueller	Steel Auto Perf Tee H-18102	\$48.07 ea.	\$48.07	
72	1	3/4" x 1"	Mueller	Auto Perf Transition Tee H-18104-04	\$88.03 ea.	\$88.03	
73	1		Thermoweld	Thermoweld Cartridge 15CP (Box of 20)	\$51.71 box	\$51.71	
74	1	2"		PVC to PVC Compression for Gas	No Bid	No Bid	
75	1	1"		PVC to PVC Compression for Gas	No Bid	No Bid	
76	1	1"	Mueller	Black Insulated Iron Body Meter Stop H-11179	\$103.19 ea.	\$103.19	
77	1	1"	Mueller	Black Iron Body Meter Stop 175 PSI H-11175	\$71.67 ea.	\$71.67	
78	1		Tinker & Rasor	Half Cell Reference Electrodes Model 6-B	\$103.57 ea.	\$103.57	
79	1		Tinker & Rasor	Copper Sulfate Crystals (1lb. 3oz.)	\$45.71 ea.	\$45.71	
80	1		Tinker & Rasor	118-027 Ceramic Tip Assembly - Pointed	\$36.43 ea.	\$36.43	
81	1	2" x 1"		PE4710 Tapping Tee Rectangular Base w/ Model EFVEB-BB7YY00 Excess Flow Valve	\$73.81 ea.	\$73.81	
82	1	4" x 1"		PE4710 Tapping Tee Rectangular Base w/ Model EFVEB-BB7YY00 Excess Flow Valve	\$80.69 ea.	\$80.69	
83	1	1"		PE4710 Excess Flow Valve 525 SCFH	\$32.10 ea.	\$32.10	
84	1	2" IPS	Poly Cam	PVC x PE4710 B.F. Transition Fitting	\$70.36 ea.	\$70.36	
85	1		Handley	Valve Box for 2" & 3" FP Poly Valve G4HAC399ACD	\$138.40 ea.	\$138.40	
86	1		Handley	2" Valve Support VV5	\$23.94 ea.	\$23.94	
87	1		Handley	4" Valve Support VV17	\$35.53 ea.	\$35.53	
88	1			Trenton Wax Tape 6" x 9' (16 Rolls Per Case)	\$52.50 ea.	\$52.50	
89	1			Trenton Wax Tape Primer Brown (4 Gal per Case)	\$153.07 ea.	\$153.07	
90	1			Barricade Tape Gas Line Below Yellow & Black	\$32.86 rl.	\$32.86	
91	500	12 gauge		#12 Solid Yellow Tracer wire 500'	\$0.24 ft.	\$118.57	
92	1			Harveys 10 Mil Pipe Wrap 2" x 100'	\$38.57 rl.	\$38.57	
93	1	32 Lbs.		Hi Potential Packaged Mag Anode w/ 10' #12 wire	\$282.71 ea.	\$282.71	
94	1	5 Lbs.		Hi Potential Packaged Mag Anode w/ 10' #12 wire	\$90.43 ea.	\$90.43	
95	1	9 Lbs.		Hi Potential Packaged Mag Anode w/ 10' #12 wire	\$135.79 ea.	\$135.79	
96	1	17 Lbs.		Hi Potential Packaged Mag Anode w/ 10' #12 wire	\$201.86 ea.	\$201.86	



97	1	48 Lbs.		Hi Potential Packaged Mag Anode w/ 10' #12 wire	\$474.14 ea.	\$474.14	
98	1	1 gal.		Low Temp Leak Detector (1 Gal Bottle)	\$58.14 ea.	\$58.14	
99	1			Yellow Inverted Marking Paint (5ea. Per Case)	\$83.57 ea.	\$83.57	

**<<<< Terms & Conditions >>>>**

- \* Payment Terms:       **30 days net.**
- \* FOB Point:           **Las Vegas, NM**
- \* Ship Via:             **Best Way**

**Additional Comments:**